

Frame / Module

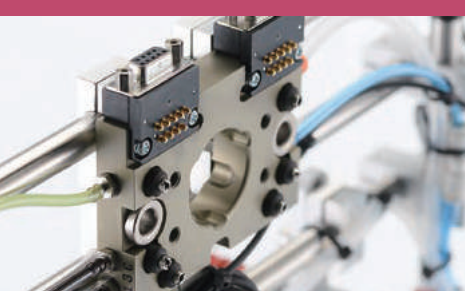

Jungle Gym 5-2

- ▶ List of Jungle Gym 5-3
- ▶ Jungle Gym SUS • CFRP Pipe / Resin Fixture 5-8
- ▶ Pipe End Cap / SUS Pipe Cutter / Clip 5-9
- ▶ Jangle Gym Series Parts (Connector) 5-10
- ▶ Jangle Gym Series Parts (Bracket) 5-13
- ▶ Jangle Gym Series Parts (Rotation) 5-19
- ▶ Jangle Gym Series Parts (Slide) 5-21
- ▶ Jangle Gym Series Parts (Washer) 5-24
- ▶ Jangle Gym Series Parts (Nut / Bushing) 5-25
- ▶ Base Frame Module 5-26
- ▶ Examples of Robot Chuck Production 5-29
- ▶ Use Cases of Parts 5-32

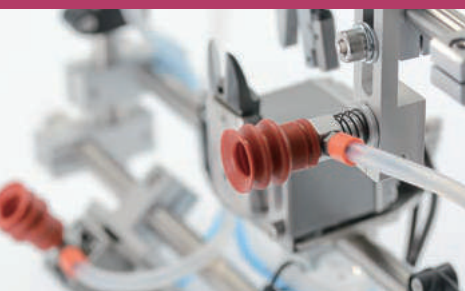

Let's Joint 5-34

- ▶ List of Let's Joint 5-35
- ▶ Base Frame Module 5-38
- ▶ Examples of Robot Chuck Production 5-40
- ▶ Use Cases of Parts 5-41



Rectangular Tube 5-42

- ▶ Rectangular Tube / Pipe End Cap 5-43
- ▶ Rectangular Tube Series Parts 5-44



Base Aluminum Material 5-46



Sliding Chuck 5-48

- ▶ Robot Hand (for Articulated Robots) 5-51

Quick Chuck Change

Quick Chuck Change Manual

Quick Chuck Change Manual (OM Type)

Tool Changer

Automated Hand Exchange System

Grip

Mini Cylinder

Accessories for Mini Cylinder

Container Cylinders

Accessories for Container Cylinder

Grippers

Rubber Material / Grip Pad

Suction

Suction Cups

Suction Stems

Pad in Pad

Vacuum Gripper

Air Ejector / Filter / Check Valve

Ultra Small Part Take Out

Vacuum Generator Unit

Cut

Air Nipper (Small-Medium)

Air Nipper (Large)

Frame / Module

Jungle Gym

Let's Joint

Rectangular Tube

Base Aluminum Material

Sliding Chuck

Pneumatic Components / Sensors

Pneumatic Components

Sensors / Multi AND Board

PCIO Communication Unit

Lightweight Parts Series

Frame / Suction / Resin Cylinder / Parts / Resin Materials

By Industry

Logistics - Palletizing
Steel Metal - Stamping
Metal Fabrication

Assembling Tools

Tool / Jig

Information

Various Products Information

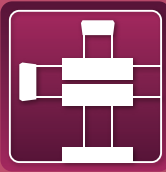

Jungle Gym

- ▶ Super lightweight, adjustable and reusable frame.
- ▶ Features rigidity and weight reduction. Frame is made of thin-wall stainless. Connectors are made fro super Duralumin.
- ▶ It is simple to adjust the components loacation,which cuts down on working time.
- ▶ The combination of multifarious chuck parts will meet a variety needs.

Frame / Module

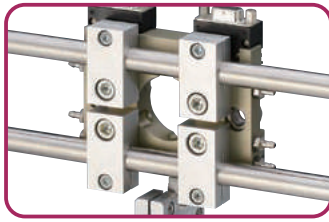

Grip

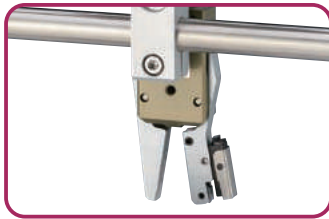

Cut

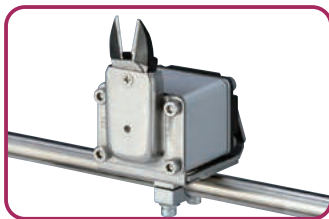

Suction

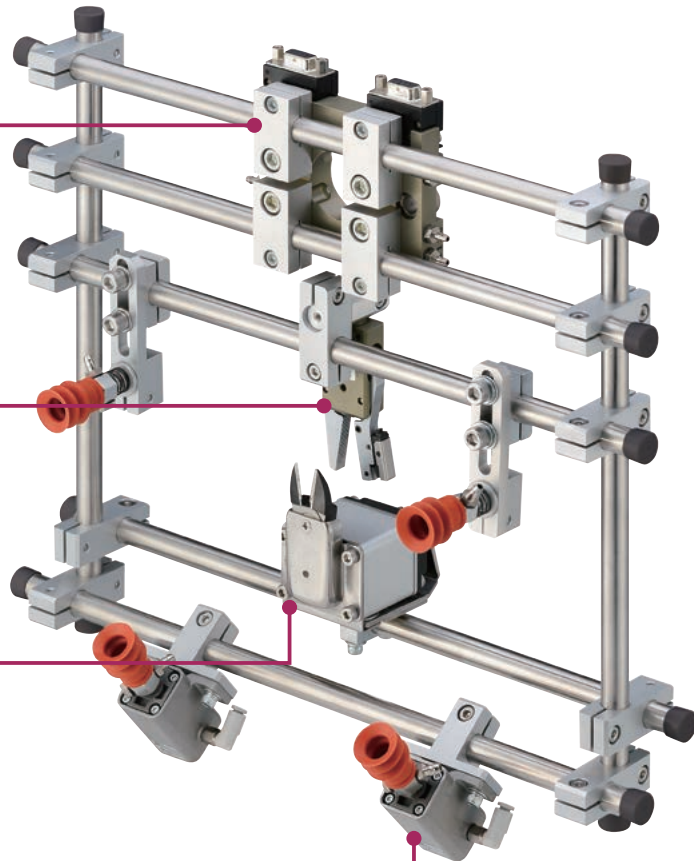
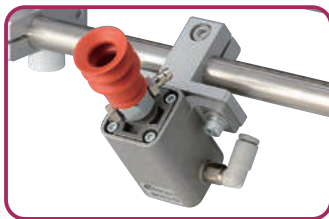

Tubing **6-1**

Three Kinds of SUS pipes ($\phi 8$ / $\phi 12$ / $\phi 20$) are available for you to use as a base for your end of arm tool.
Determine extract method first. And choose your favorite parts from the product list.

Example of using other components parts

- ▶ Suction cups + Suction stems + Rotation bracket + Cross connector

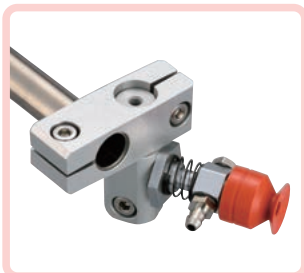

Order code No.	210193
TYPE	VAPH-15C



Order code No.	131173
TYPE	N01864-306



Order code No.	210974
TYPE	VFIL-S-5A



Order code No.	131099
TYPE	N01861-202

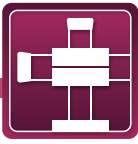

List of Jungle Gym

Various parts can be attached to jungle gym SUS $\phi 8$, $\phi 12$, and $\phi 20$.

Jungle gym



You can see moving images of products by using QR code reader of your smartphone.

Specification

Product name	Order code No.	Page of details
Jungle gym SUS pipe $\phi 8$	340905	5-8
	8*0.6*500	
	340906	
	8*0.6*1000	
	340907	
Jungle gym SUS pipe $\phi 12$	271527	5-8
	12*0.6*500	
	271528	
	12*0.6*1000	
	271529	
Jungle gym SUS pipe $\phi 20$	281812	5-8
	20*0.8*500	
	281813	
	20*0.8*1000	
Jungle gym CFRP pipe $\phi 12$	023361	5-8
	CFRP 12 * 1.5 * 1500	
Jungle gym CFRP pipe $\phi 20$	023362	5-8
	CFRP 20 * 1.5 * 1500	
Resin Fixture $\phi 12$ (Cable Ties)	171210	5-9
	RCA12	
	171211	
	RCA20	
Resin Fixture $\phi 20$ (Cable Ties)	171212	5-9
	RCB12	
Resin Fixture $\phi 12$ (M4)	171213	5-9
	RCB20	
Pipe end cap $\phi 8$	171338	5-9
	R-CAP-8	
	171339	
Pipe end cap $\phi 12$	171339	5-9
	R-CAP-12	
Pipe end cap $\phi 20$	171340	5-9
	R-CAP-20	
SUS pipe cutter	101206	5-9
	K-203	
Spare blade for pipe cutter	101207	5-9
	K-203-1	

Product name	Order code No.	Page of details
Pipe reamer	197173	5-9
	TSR-2	
Clip	196559	5-9
	TMA-CL (20*20)	
	196560	
	TMA-CL (20*12)	
	196561	
	TMA-CL (12*12)	
Clip	196562	5-9
	TMA-CL (12*8)	
	196563	
TMA-CL (8*8)	5-9	
196564		
TMA-CL (12*10)	5-9	
131102		5-10
N01861-207		
131098	5-10	
N01861-201		
131099	5-10	
N01861-202		
131100	5-10	
N01861-204		
131101	5-10	
N01861-206		
131573	5-10	
N01861-206B		
131569	5-10	
N01861-202A		
131570	5-10	
N01861-206A		
054346	5-10	
F-CROSS-12		
054347	5-10	
F-CROSS-20		
131108	5-10	
N01861-306		
131105	5-10	
N01861-303		
131104	5-11	
N01861-302		

Quick Chuck Change

Quick Chuck Change Manual

Quick Chuck Change Manual (OM Type)

Tool Changer

Automated Hand Exchange System

Grip

Mini Cylinder

Accessories for Mini Cylinder

Container Cylinders

Accessories for Container Cylinder

Grippers

Rubber Material / Grip Pad

Suction

Suction Cups

Suction Stems

Pad in Pad

Vacuum Gripper

Air Ejector / Filter / Check Valve

Ultra Small Part Take Out

Vacuum Generator Unit

Cut

Air Nipper (Small-Medium)

Air Nipper (Large)

Frame / Module

Jungle Gym

Let's Joint

Rectangular Tube

Base Aluminum Material

Sliding Chuck

Pneumatic Components / Sensors

Pneumatic Components

Sensors / Multi AND Board

PCIO Communication Unit

Lightweight Parts Series

Frame / Section / Resin Cylinders / Pads / Resin Manifolds

By Industry

Logistics-Palletizing/Sheet Metal-Stamping-Metal Fabrication













Assembling Tools









Tool / Jig

Information

Various Products Information

List of Jungle Gym

Product name	Order code No. TYPE	Page of details		
Connector	T Connector # 1 • $\phi 12 \phi 12$		131103 N01861-301	5-11
	T Connector # 1 • $\phi 12 \phi 20$		131109 N01861-307	
	T Connector # 1 • $\phi 20 \phi 12$		131106 N01861-304	
	T Connector # 1 • $\phi 20 \phi 20$		131107 N01861-305	
	T Connector # 2 • $\phi 8 \phi 8$		131115 N01861-406	
	T Connector # 2 • $\phi 8 \phi 12$		131112 N01861-403	
	T Connector # 2 • $\phi 12 \phi 8$		131111 N01861-402	
	T Connector # 2 • $\phi 12 \phi 12$		131110 N01861-401	
	T Connector # 2 • $\phi 12 \phi 20$		131116 N01861-407	
	T Connector # 2 • $\phi 20 \phi 12$		131113 N01861-404	
	T Connector # 2 • $\phi 20 \phi 20$		131114 N01861-405	
	Parallel connector • $\phi 8 \phi 8$		131096 N01861-107	5-12
			131092 N01861-101	
			131093 N01861-102	
			131094 N01861-104	
			131095 N01861-106	
	Parallel connector • $\phi 20 \phi 12$		131097 N01861-108	5-13
			054344 F-PARA-12	

Product name	Order code No. TYPE	Page of details			
Connector	Floating Paraller Connector $\phi 20$		054345 F-PARA-20	5-13	
	Straight connector • $\phi 8$		131488 N01868-501		
			131489 N01868-502		
			131490 N01868-503		
	Access bracket • $\phi 12 \cdot M6$		131125 N01862-210		5-13
			131126 N01862-211		
	Attachment bracket • $\phi 8 \cdot M5$		131306 N01862-208		5-13
			131121 N01862-205		
	Attachment bracket • $\phi 8 \cdot M6$		131305 N01862-204		5-13
			131118 N01862-201		
Attachment bracket • $\phi 12 \cdot M5$		131225 N01862-213	5-14		
		131123 N01862-207			
Attachment bracket • $\phi 12 \cdot M6$		131226 N01862-214	5-14		
		131122 N01862-206			
Suction bracket • $\phi 8 \cdot M5$		131124 N01862-209	5-14		
		131119 N01862-202			
Suction bracket • $\phi 8 \cdot M6$		131127 N01862-212	5-14		
		131120 N01862-203			













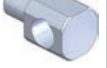
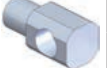

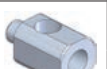

Product name		Order code No.	Page of details
Bracket	Cylinder bracket • $\phi 8$	131075	5-14
		N01915-113	
	Cylinder bracket • $\phi 12$	131074	5-15
		N01915-112	
	Cylinder bracket • $\phi 20$	131066	5-16
		N01915-103	
	Swing Bracket	131065	5-17
		N01915-102	
	Slide bracket • $\phi 8$	131151	5-18
		N01863-207	
	Slide bracket • $\phi 12$	131145	5-19
		N01863-201	
	Slide bracket • $\phi 20$	131149	5-20
		N01863-205	
	Slide bracket • W • $\phi 8$	131217	5-21
		N01863-113	
	Slide bracket • W • $\phi 12$	131128	5-22
		N01863-101	
	Slide bracket • W • $\phi 20$	131134	5-23
N01863-111			
Sensor bracket • $\phi 12$	131189	5-24	
	N01867-101		
Sensor bracket	131077	5-25	
	N01915-201		
Chuck bracket • TH • $\phi 8$	131188	5-26	
	N01866-502		
Chuck bracket • TH • $\phi 12$	131187	5-27	
	N01866-501		
Chuck bracket • $\phi 12$	131067	5-28	
	N01915-105		
Nipper bracket • A	131078	5-29	
	N01915-301		
Nipper bracket • B	131216	5-30	
	N01915-302		
Nipper bracket • C	131080	5-31	
	N01915-303		



















Product name		Order code No.	Page of details
Bracket	Nipper bracket • D	131081	5-32
		N01915-304	
	Nipper bracket • E	131082	5-33
		N01915-305	
	Bracket • L • $\phi 8$ • for UMCD	131180	5-34
		N01866-202	
	Bracket • L • $\phi 12$ • for MCD	131179	5-35
		N01866-201	
	Bracket • T • $\phi 12$ • for MCD	131176	5-36
		N01866-101	
	Bracket • T • $\phi 20$ • for MCD	131554	5-37
		N01866-103A	
	Bracket • T • $\phi 8$ • for UMCD	131177	5-38
		N01866-102	
	Bracket • TH • $\phi 8$ • for UMCD	131182	5-39
		N01866-302	
	Bracket • TH • $\phi 12$ • for MCD	131181	5-40
		N01866-301	
	Bracket • TH • $\phi 20$ • for MCD	131183	5-41
N01866-303			
Bracket • TV • $\phi 8$ • for UMCD	131185	5-42	
	N01866-402		
Bracket • TV • $\phi 12$ • for MCD	131184	5-43	
	N01866-401		
Bracket • TV • $\phi 20$ • for MCD	131186	5-44	
	N01866-403		
Bracket • $\phi 8$	131073	5-45	
	N01915-111		
Bracket • $\phi 12$	131071	5-46	
	N01915-109		
Bracket • $\phi 20$	131072	5-47	
	N01915-110		
Bracket • W • $\phi 8$	131070	5-48	
	N01915-108		
Bracket • W • $\phi 12$	131068	5-49	
	N01915-106		

Quick Chuck Change

- Quick Chuck Change Manual
- Quick Chuck Change Manual (OM Type)
- Tool Changer
- Automated Hand Exchange System
- Grip**
- Mini Cylinder
- Accessories for Mini Cylinder
- Container Cylinders
- Accessories for Container Cylinder
- Grippers
- Rubber Material / Grip Pad
- Suction**
- Suction Cups
- Suction Stems
- Pad in Pad
- Vacuum Gripper
- Air Ejector / Filter / Check Valve
- Ultra Small Part Take Out
- Vacuum Generator Unit
- Cut**
- Air Nipper (Small-Medium)
- Air Nipper (Large)
- Frame / Module**
- Jungle Gym**
- Let's Joint
- Rectangular Tube
- Base Aluminum Material
- Sliding Chuck
- Pneumatic Components / Sensors**
- Pneumatic Components
- Sensors / Multi AND Board
- PCIO Communication Unit
- Lightweight Parts Series**
- Frame / Suction / Resin Cylinders / Pads / Resin Manifolds
- By Industry**
- Logistics-Palletizing/Sheet Metal-Stamping-Metal Fabrication
- Assembling Tools**
- Tool / Jig
- Information**
- Various Products Information

List of Jungle Gym

Product name	Order code No. TYPE	Page of details	
Bracket	Bracket • W • ϕ 20	 131069 N01915-107	5-19
	Bracket • NCON	 131083 N01915-401	
	Rotation bracket • ϕ 20	 131064 N01915-101	
	Rotation bracket • M10 • 8A	 131434 N01864-305	
	Rotation bracket • M12 • 12A	 131173 N01864-306	
	Rotation bracket • M17 • 20A	 131174 N01864-307	
	Rotation bracket • PT1/8 • 8A	 131175 N01864-401	
	Rotation bracket • ϕ 8 • 8A	 131170 N01864-303	
	Rotation bracket • ϕ 8 • 8B	 131606 N01864-103A	
	Rotation bracket • ϕ 8 • M5A	 131164 N01864-202	
	Rotation bracket • ϕ 8 • M10A	 131435 N01864-201	
	Rotation bracket • ϕ 8 • M12A	 131433 N01864-205	
	Rotation bracket • ϕ 12 • PT1/8A	 131166 N01864-204	
	Rotation bracket • ϕ 12 • 8A	 131169 N01864-302	
	Rotation bracket • ϕ 12 • 8B	 131600 N01864-101A	
	Rotation bracket • ϕ 12 • 12A	 131168 N01864-301	
	Rotation BKT • ϕ 12 • 12AL	 131567 N01864-301L	
	Rotation bracket • ϕ 12 • 12B	 131605 N01864-102A	

Product name	Order code No. TYPE	Page of details	
Bracket	Rotation bracket • ϕ 20 • 20A	 131171 N01864-304	5-20
	Rotation BKT • ϕ 20 • 20AL	 131568 N01864-304L	
Rotation	Suction rotate # A • ϕ 8	 131194 N01868-104	5-21
	Suction rotate # A • ϕ 12	 131191 N01868-101	
	Suction rotate # B • M5 • ϕ 12	 131192 N01868-102	
	Slide bracket 40 • M3	 131158 N01863-214	
	Slide bracket 40 • M5	 131147 N01863-203	
	Slide bracket 40 • M6	 131156 N01863-212	
	Slide bracket 40 • PT1/8	 131154 N01863-210	
	Slide bracket 40 • W • M10	 131139 N01863-117	
	Slide bracket 40 • W • M12	 131140 N01863-118	
	Slide bracket 40 • W • M17	 131143 N01863-122	
Bracket	Slide bracket 40 • ϕ 8	 131152 N01863-208	5-22
	Slide bracket 40 • W • ϕ 8	 131131 N01863-106	
	Slide bracket 40 • W • ϕ 12	 131132 N01863-107	
	Slide bracket 40 • W • ϕ 20	 131137 N01863-114	
	Slide bracket 40 • T • W • ϕ 8	 230051 XL0005-102	
	Slide bracket 40 • T • ϕ 8	 230056 XL0005-107	

Product name		Order code No.	Page of details
Bracket	Slide bracket 40 • T • ϕ 12	230052	5-22
		XL0005-103	
	Slide bracket 40 • T • ϕ 20	230054	5-22
		XL0005-105	
	Slide bracket 70 • M3	131159	5-23
		N01863-217	
	Slide bracket 70 • M5	131148	5-23
		N01863-204	
	Slide bracket 70 • M6	131157	5-23
		N01863-213	
	Slide bracket 70 • PT1/8	131155	5-23
		N01863-211	
	Slide bracket 70 • W • M10	131141	5-23
		N01863-120	
	Slide bracket 70 • W • M12	131142	5-23
		N01863-121	
	Slide bracket 70 • W • M17	131144	5-23
		N01863-124	
	Slide bracket 70 • ϕ 8	131153	5-25
		N01863-209	
Slide bracket 70 • W • ϕ 8	131133	5-25	
	N01863-110		
Slide bracket 70 • W • ϕ 12	131130	5-25	
	N01863-103		
Slide bracket 70 • W • ϕ 20	131138	5-25	
	N01863-115		
Slide bracket 70 • T • W • ϕ 8	230053	5-24	
	XL0005-104		
Slide bracket 70 • T • ϕ 8	230057	5-24	
	XL0005-108		
Slide bracket 70 • T • ϕ 12	230050	5-24	
	XL0005-101		
Slide bracket 70 • T • ϕ 20	230055	5-24	
	XL0005-106		
Washer	Slide washer • ϕ 8 / ϕ 12	131146	5-24
		N01863-202	

Product name		Order code No.	Page of details
Washer	Slide washer • W • ϕ 8 / ϕ 12	131129	5-24
		N01863-102	
	Slide washer • ϕ 20	131150	
Nut plate	Nut plate for slide bracket	131135	5-24
		N01863-206	
Nut	Bushing nut • ϕ 8 • M5	131135	5-25
		N01863-112	
Nut	Bushing nut • ϕ 8 • M6	023197	5-25
		CP-076	
	Bushing nut • ϕ 8 • M5	131200	
		N01868-401	
	Bushing nut • ϕ 8 • M6	131206	
		N01868-410	
	Bushing nut • ϕ 12 • M5	131202	
		N01868-403	
	Bushing nut • ϕ 12 • M10	131201	
		N01868-402	
Bushing nut • ϕ 12 • PT1/8	131207		
	N01868-411		
Bushing nut • ϕ 20 • M12	131205		
	N01868-409		
Bushing nut • ϕ 20 • PT1/8	131199		
	N01868-305		
Bushing nut • M5-M3	131204		
	N01868-407		
Bushing	Bushing • ϕ 12 ϕ 8	131196	
		N01868-301	
	Bushing • ϕ 20 ϕ 8	131197	
		N01868-302	
Bushing • ϕ 20 ϕ 12	131198		
	N01868-303		

Quick Chuck Change

Quick Chuck Change Manual
Quick Chuck Change Manual (OM Type)
Tool Changer
Automated Hand Exchange System
Grip
Mini Cylinder
Accessories for Mini Cylinder
Container Cylinders
Accessories for Container Cylinder
Grippers
Rubber Material / Grip Pad
Suction
Suction Cups
Suction Stems
Pad in Pad
Vacuum Gripper
Air Ejector / Filter / Check Valve
Ultra Small Part Take Out
Vacuum Generator Unit
Cut
Air Nipper (Small-Medium)
Air Nipper (Large)
Frame / Module
Jungle Gym
Let's Joint
Rectangular Tube
Base Aluminum Material
Sliding Chuck
Pneumatic Components / Sensors
Pneumatic Components
Sensors / Multi AND Board
PCIO Communication Unit
Lightweight Parts Series
Frame / Suction / Resin Cylinders / Pads / Resin Manifolds
By Industry
Logistics-Palletizing/Sheet Metal-Stamping-Metal Fabrication
Assembling Tools
Tool / Jig
Information
Various Products Information

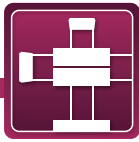

Jungle Gym SUS • CFRP Pipe / Resin Fixture

Using thin-walled stainless steel pipes allows weight reduction and structural rigidity.

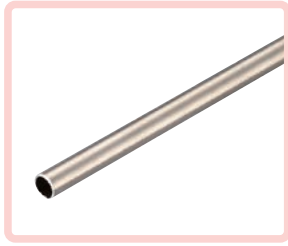

Jungle gym SUS pipe φ 8

Order code No.	340905
TYPE	8*0.6*500

● Weight : 56g

Order code No.	340906
TYPE	8*0.6*1000

● Weight : 112g

Order code No.	340907
TYPE	8*0.6*1500

● Weight : 144g

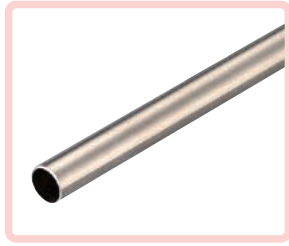

Jungle gym SUS pipe φ 12

Order code No.	271527
TYPE	12*0.6*500

● Weight : 88g

Order code No.	271528
TYPE	12*0.6*1000

● Weight : 169g

Order code No.	271529
TYPE	12*0.6*1500

● Weight : 250g

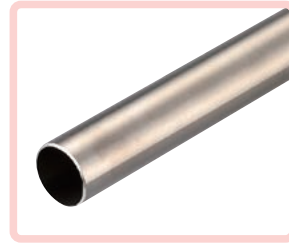

Jungle gym SUS pipe φ 20

Order code No.	281812
TYPE	20*0.8*500

● Weight : 172g

Order code No.	281813
TYPE	20*0.8*1000

● Weight : 352g

Order code No.	281814
TYPE	20*0.8*1500

● Weight : 543g

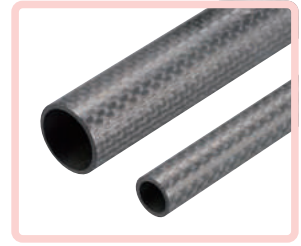

Jungle gym CFRP pipe φ 12

Order code No.	023361
TYPE	CFRP 12*1.5*1500

● Weight : 121g

Jungle gym CFRP pipe φ 20

Order code No.	023362
TYPE	CFRP 20*1.5*1500

● Weight : 200g

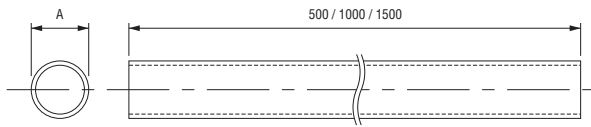

■ Specification

Product name	A	Thickness	Material	Outside diameter tolerance
Jungle gym SUS pipe φ 8	φ 8	0.6mm	SUS304	0 ~ - 0.06
Jungle gym SUS pipe φ 12	φ 12			
Jungle gym SUS pipe φ 20	φ 20	0.8mm	CFRP	0 ~ - 0.10
Jungle gym CFRP pipe φ 12	φ 12	1.5mm		- 0.05 ~
Jungle gym CFRP pipe φ 20	φ 20			- 0.15

*The tolerance of outside diameter is a rough standard.

*When cutting pipes, burrs may occur on the cut surface.



Resin Fixture φ 12 (Cable ties)

Order code No.	171210
TYPE	RCA12

● Weight : 5g

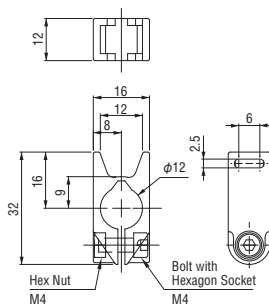

Resin Fixture φ 20 (Cable ties)

Order code No.	171211
TYPE	RCA20

● Weight : 7g

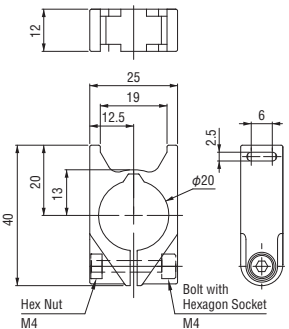

Resin Fixture φ 12 (M4)

Order code No.	171212
TYPE	RCB12

● Weight : 6g

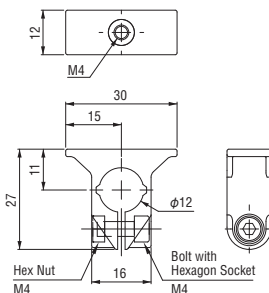

Resin Fixture φ 20 (M4)

Order code No.	171213
TYPE	RCB20

● Weight : 9g

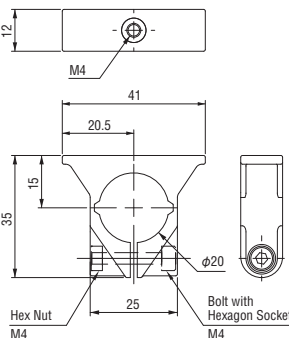

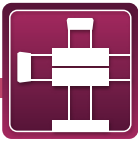

Pipe End Cap / SUS Pipe Cutter / Clip

Caps, pipe cutters, and clips compatible with SUS / CFRP pipes.

● Use Semedine Super X Series to fix the pipe end cap to jungle gym SUS pipe.



Pipe end cap $\phi 8$

Order code No.	171338
TYPE	R-CAP-8

● Weight : 0.2g

Pipe end cap $\phi 12$

Order code No.	171339
TYPE	R-CAP-12

● Weight : 0.4g

Pipe end cap $\phi 20$

Order code No.	171340
TYPE	R-CAP-20

● Weight : 3.0g



Clip • TMA • $\phi 20 * \phi 20$

Order code No.	196559
TYPE	TMA-CL (20*20)

● Weight : 270g

Clip • TMA • $\phi 20 * \phi 12$

Order code No.	196560
TYPE	TMA-CL (20*12)

● Weight : 160g

Clip • TMA • $\phi 12 * \phi 12$

Order code No.	196561
TYPE	TMA-CL (12*12)

● Weight : 75g

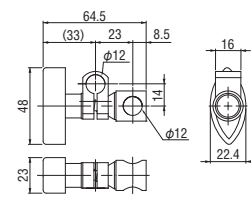
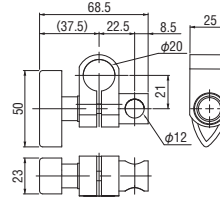
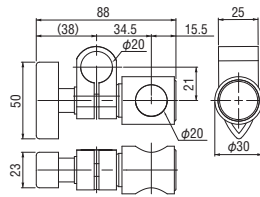

Clip • TMA • $\phi 12 * \phi 8$

Order code No.	196562
TYPE	TMA-CL (12*8)

● Weight : 85g

Clip • TMA • $\phi 8 * \phi 8$

Order code No.	196563
TYPE	TMA-CL (8*8)

● Weight : 55g

Clip • TMA • $\phi 12 * \phi 10$

Order code No.	196564
TYPE	TMA-CL (12*10)

● Weight : 62g

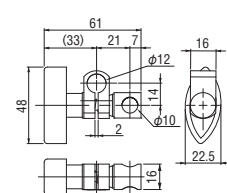
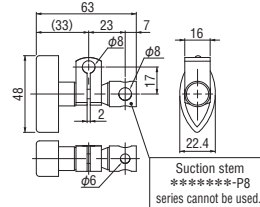
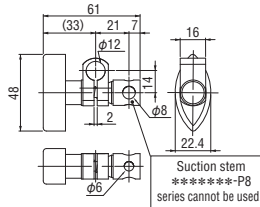

SUS pipe cutter

Order code No.	101206
TYPE	K-203

● Weight : 205g
● Coping with stainless steel pipe, copper tubes

SUS pipe cutter blade

Order code No.	101207
TYPE	K-203-1

● Weight : 3g
● Pipe cutter (K-203) spare blade

How to use

1 When you turn the handle clockwise, the blade moves forward, when you turn the handle counterclockwise, the blade moves backward. Put the pipe onto the two rollers parallel as shown. Turn the handle to the point where the blade contacts with the pipe. Turn the handle to the point where the blade contacts with the pipe.

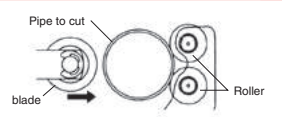

2 Take the pipe as center and rotate the pipe cutter in the direction of the arrow in the figure. Turn the handle clockwise a little by one rotation, and move the blade forward. Repeat the operation, the pipe will be cut off.



Pipe Reamer (Copper / Stainless Tube)

Order code No.	197173
TYPE	TSR-2

● Weight : 200g
● Suitable for pipe : $\phi 8 \sim 35\text{mm}$

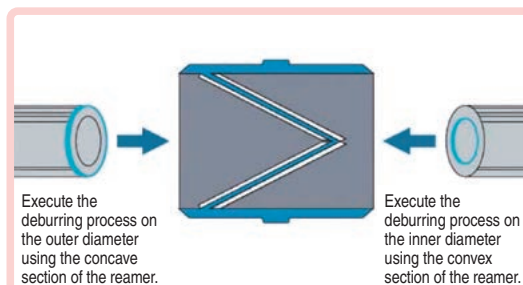

Quick Chuck Change

Quick Chuck Change Manual

Quick Chuck Change Manual (OM Type)

Tool Changer

Automated Hand Exchange System

Grip

Mini Cylinder

Accessories for Mini Cylinder

Container Cylinders

Accessories for Container Cylinder

Grippers

Rubber Material / Grip Pad

Suction

Suction Cups

Suction Stems

Pad in Pad

Vacuum Gripper

Air Ejector / Filter / Check Valve

Ultra Small Part Take Out

Vacuum Generator Unit

Cut

Air Nipper (Small-Medium)

Air Nipper (Large)

Frame / Module

Jungle Gym

Let's Joint

Rectangular Tube

Base Aluminum Material

Sliding Chuck

Pneumatic Components / Sensors

Pneumatic Components

Sensors / Multi AND Board

PCIO Communication Unit

Lightweight Parts Series

Frame / Suction / Resin Cylinders / Pads / Resin Manifolds

By Industry

Logistics - Palletizing / Sheet Metal - Stamping - Metal Fabrication

Assembling Tools

Tool / Jig

Information

Various Products Information

Quick Chuck Change

Quick Chuck Change Manual

Quick Chuck Change Manual (OM Type)

Tool Changer

Automated Hand Exchange System

Grip

Mini Cylinder

Accessories for Mini Cylinder

Container Cylinders

Accessories for Container Cylinder

Grippers

Rubber Material / Grip Pad

Suction

Suction Cups

Suction Stems

Pad in Pad

Vacuum Gripper

Air Ejector / Filter / Check Valve

Ultra Small Part Take Out

Vacuum Generator Unit

Cut

Air Nipper (Small-Medium)

Air Nipper (Large)

Frame / Module

Jungle Gym

Let's Joint

Rectangular Tube

Base Aluminum Material

Sliding Chuck

Pneumatic Components / Sensors

Pneumatic Components

Sensors / Multi AND Board

PCIO Communication Unit

Lightweight Parts Series

Frame / Section / Resin Cylinders (Pads) / Resin Manifolds

By Industry

Logistics - Palletizing / Sheet Metal - Stamping - Metal Fabrication

Assembling Tools

Tool / Jig

Information

Various Products Information

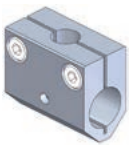

T Connector # 1 • $\phi 12 \phi 8$

Order code No. **131104**
TYPE **N01861-302**

● Weight : 18.7g

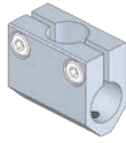
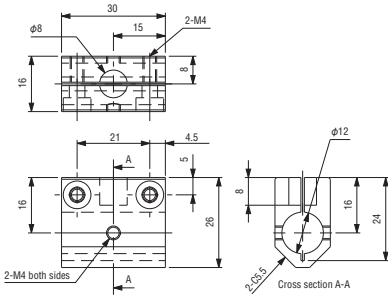

T Connector # 1 • $\phi 12 \phi 12$

Order code No. **131103**
TYPE **N01861-301**

● Weight : 17.5g

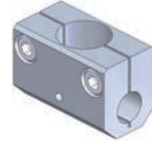
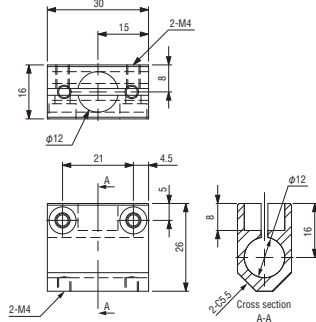

T Connector # 1 • $\phi 12 \phi 20$

Order code No. **131109**
TYPE **N01861-307**

● Weight : 57.8g

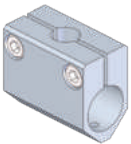
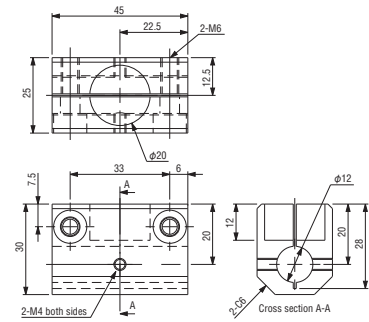

T Connector # 1 • $\phi 20 \phi 12$

Order code No. **131106**
TYPE **N01861-304**

● Weight : 62.4g

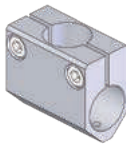
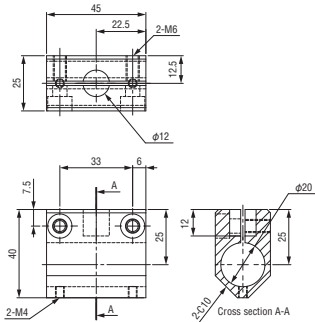

T Connector # 1 • $\phi 20 \phi 20$

Order code No. **131107**
TYPE **N01861-305**

● Weight : 55.9g

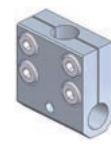
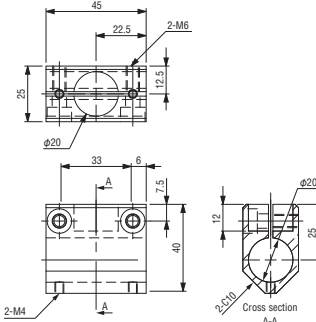

T Connector # 2 • $\phi 8 \phi 8$

Order code No. **131115**
TYPE **N01861-406**

● Weight : 14.6g

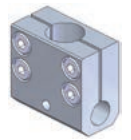
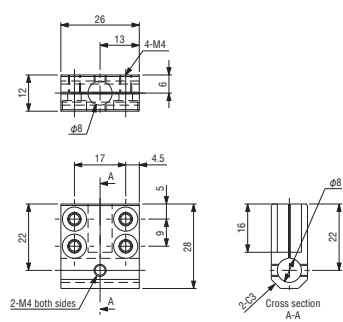

T Connector # 2 • $\phi 8 \phi 12$

Order code No. **131112**
TYPE **N01861-403**

● Weight : 30.8g

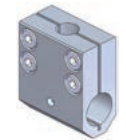
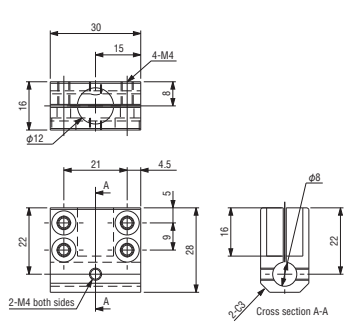

T Connector # 2 • $\phi 12 \phi 8$

Order code No. **131111**
TYPE **N01861-402**

● Weight : 28.3g

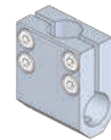
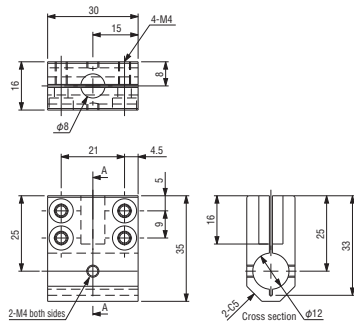

T Connector # 2 • $\phi 12 \phi 12$

Order code No. **131110**
TYPE **N01861-401**

● Weight : 25.7g

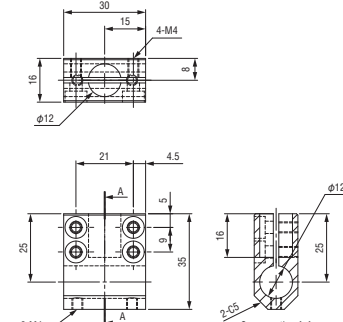

Jungle Gym Series Parts

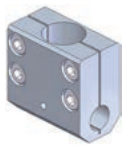

**T Connector # 2 •
φ 12 φ 20**

Order code No.	131116
TYPE	N01861-407

● Weight : 87.2g

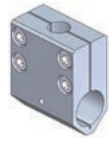
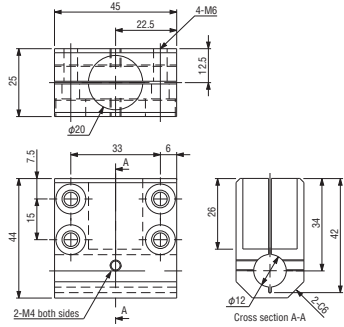

**T Connector # 2 •
φ 20 φ 12**

Order code No.	131113
TYPE	N01861-404

● Weight : 107.4g

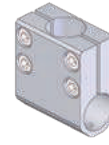
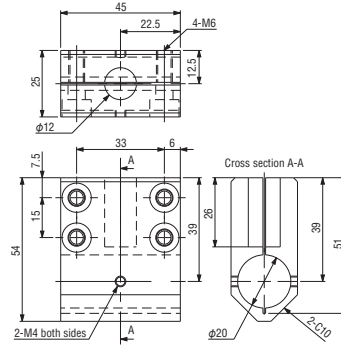

**T Connector # 2 •
φ 20 φ 20**

Order code No.	131114
TYPE	N01861-405

● Weight : 77.3g

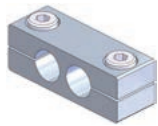
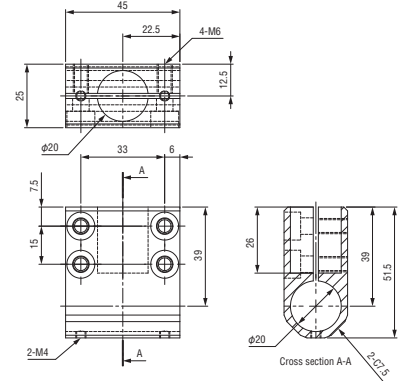

**Parallel connector •
φ 8 φ 8**

Order code No.	131096
TYPE	N01861-107

● Weight : 9.1g

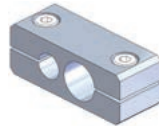
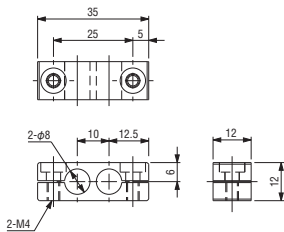

**Parallel connector •
φ 8 φ 12**

Order code No.	131092
TYPE	N01861-101

● Weight : 20.6g

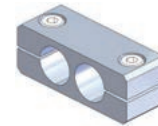
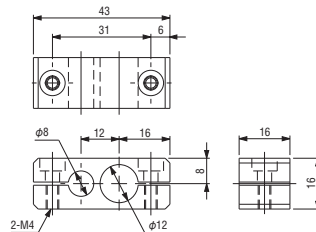

**Parallel connector •
φ 12 φ 12**

Order code No.	131093
TYPE	N01861-102

● Weight : 18.6g

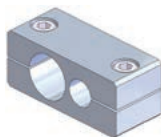
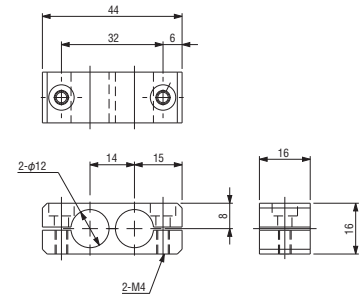

**Parallel connector •
φ 20 φ 12**

Order code No.	131094
TYPE	N01861-104

● Weight : 67.2g

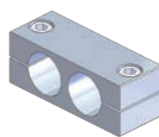
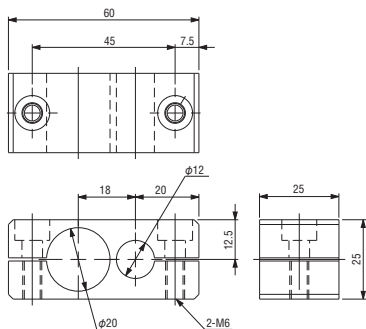

**Parallel connector •
φ 20 φ 20**

Order code No.	131095
TYPE	N01861-106

● Weight : 60.7g

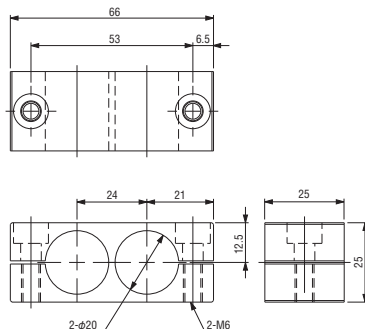

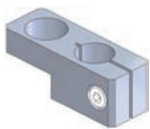

Connector • for SSW

Order code No.	131097
TYPE	N01861-108

● Weight : 15.5g

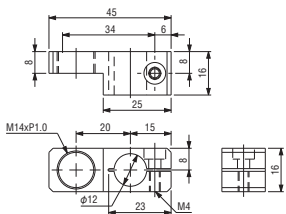

Floating Paraller Connector φ12

Order code No.	054344
TYPE	F-PARA-12

● Weight : 40.0g

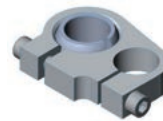
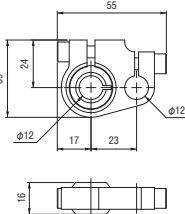

Floating Paraller Connector φ20

Order code No.	054345
TYPE	F-PARA-20

● Weight : 56.0g

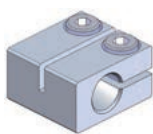
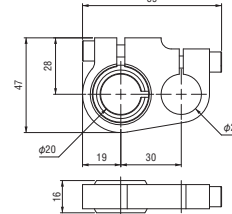

Straight connector • φ8

Order code No.	131488
TYPE	N01868-501

● Weight : 12.2g

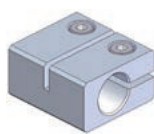
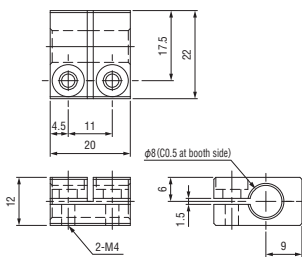

Straight connector • φ12

Order code No.	131489
TYPE	N01868-502

● Weight : 26.8g

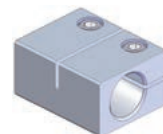
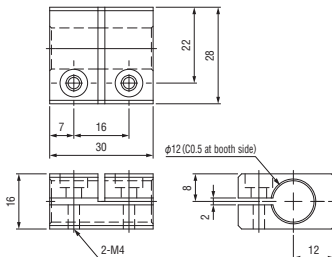

Straight connector • φ20

Order code No.	131490
TYPE	N01868-503

● Weight : 102.1g

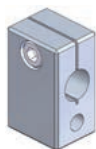
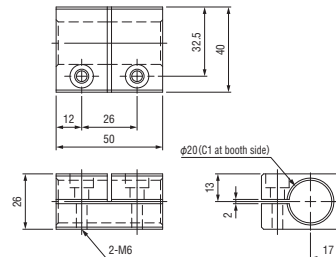

Access bracket • φ12 • M6

Order code No.	131125
TYPE	N01862-210

● Weight : 41.5g

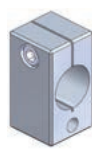
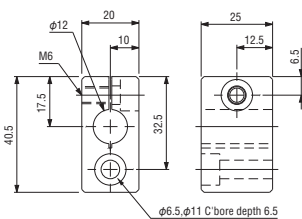

Access bracket • φ20 • M6

Order code No.	131126
TYPE	N01862-211

● Weight : 50.8g

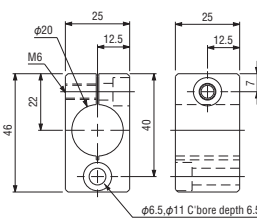

Attachment bracket • φ8 • M5

Order code No.	131306
TYPE	N01862-208

● Weight : 15.0g

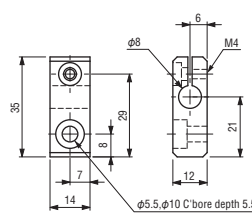

Attachment bracket • φ8 • M6

Order code No.	131121
TYPE	N01862-205

● Weight : 11.1g

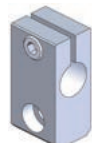
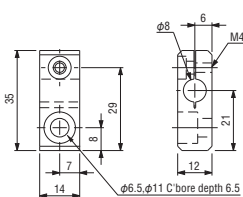

Attachment bracket • φ12 • M5

Order code No.	131305
TYPE	N01862-204

● Weight : 30.0g

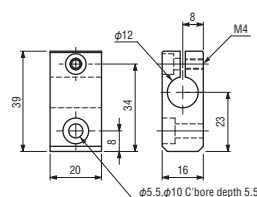

Attachment bracket • φ12 • M6

Order code No.	131118
TYPE	N01862-201

● Weight : 24.1g

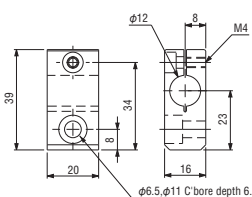

Quick Chuck Change

Quick Chuck Change Manual

Quick Chuck Change Manual (OM Type)

Tool Changer

Automated Hand Exchange System

Grip

Mini Cylinder

Accessories for Mini Cylinder

Container Cylinders

Accessories for Container Cylinder

Grippers

Rubber Material / Grip Pad

Suction

Suction Cups

Suction Stems

Pad in Pad

Vacuum Gripper

Air Ejector / Filter / Check Valve

Ultra Small Part Take Out

Vacuum Generator Unit

Cut

Air Nipper (Small-Medium)

Air Nipper (Large)

Frame / Module

Jungle Gym

Let's Joint

Rectangular Tube

Base Aluminum Material

Sliding Chuck

Pneumatic Components / Sensors

Pneumatic Components

Sensors / Multi AND Board

PCIO Communication Unit

Lightweight Parts Series

Frame / Section / Resin Cylinders / Pads / Resin Manifolds

By Industry

Logistics - Palletizing / Sheet Metal - Stamping - Metal Fabrication

Assembling Tools

Tool / Jig

Information

Various Products Information

Jungle Gym Series Parts



**Attachment bracket •
φ 12 • M8**

Order code No.	131225
TYPE	N01862-213

● Weight : 41.5g

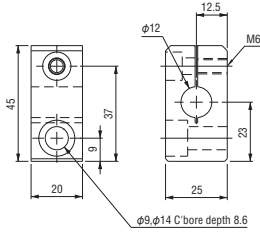

**Attachment bracket •
φ 20 • M6**

Order code No.	131123
TYPE	N01862-207

● Weight : 44.7g

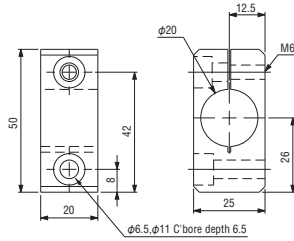

**Attachment bracket •
φ 20 • M8**

Order code No.	131226
TYPE	N01862-214

● Weight : 50.7g

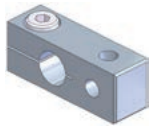
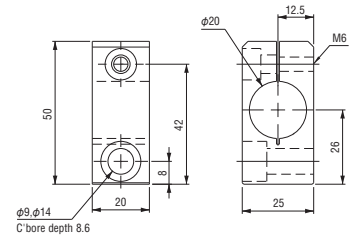

**Suction bracket •
φ 8 • M5**

Order code No.	131122
TYPE	N01862-206

● Weight : 8.1g

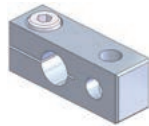
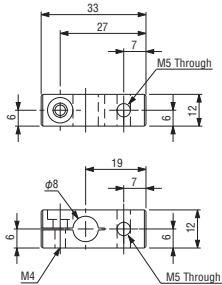

**Suction bracket •
φ 8 • M6**

Order code No.	131124
TYPE	N01862-209

● Weight : 7.8g ● M6 (fine)

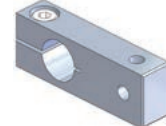
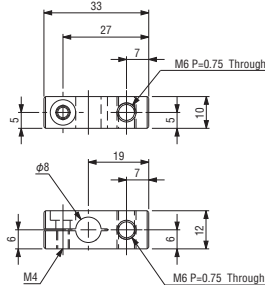

**Suction bracket •
φ 12 • M5**

Order code No.	131119
TYPE	N01862-202

● Weight : 15.7g

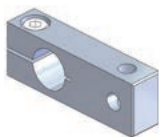
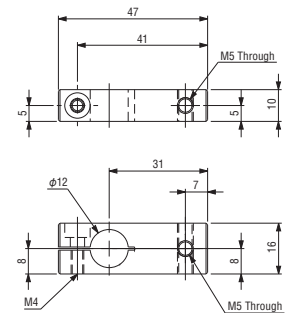

**Suction bracket •
φ 12 • M6**

Order code No.	131127
TYPE	N01862-212

● Weight : 15.4g ● M6 (fine)

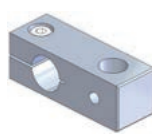
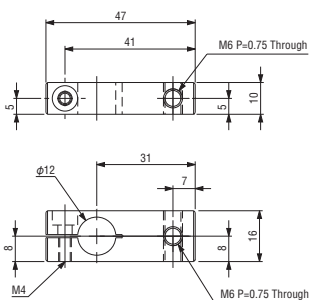

**Suction bracket •
φ 12 • PT1/8**

Order code No.	131120
TYPE	N01862-203

● Weight : 24.1g

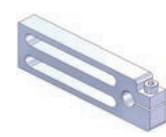
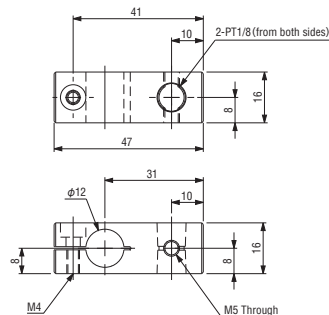

**Cylinder bracket •
φ 8**

Order code No.	131075
TYPE	N01915-113

● Weight : 44g

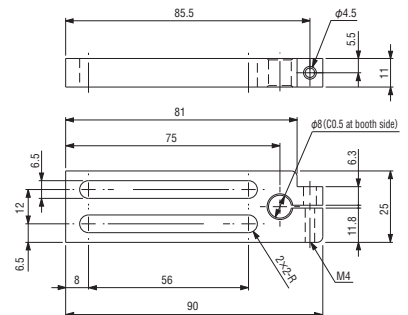

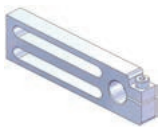

Cylinder bracket • ϕ 12

Order code No.	131074
TYPE	N01915-112

● Weight : 45g

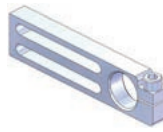
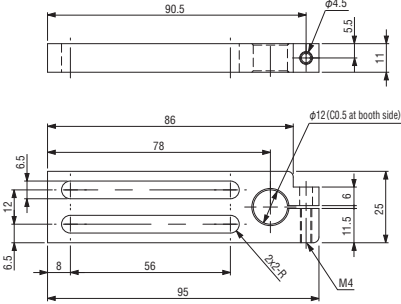

Cylinder bracket • ϕ 20

Order code No.	131066
TYPE	N01915-103

● Weight : 49g

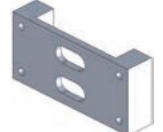
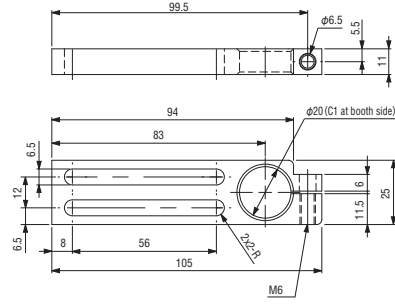

Swing Bracket

Order code No.	131065
TYPE	N01915-102

● Weight : 32.1g

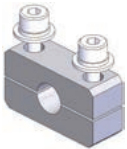
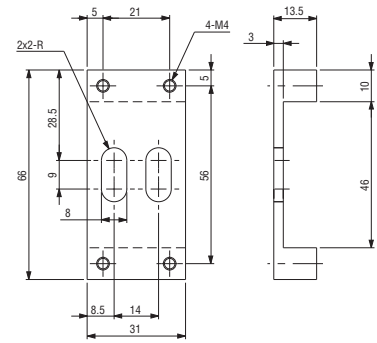

Slide bracket • ϕ 8

Order code No.	131151
TYPE	N01863-207

● Weight : 10.4g

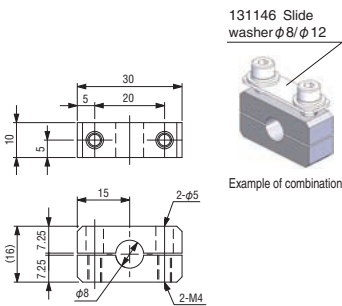

131146 Slide washer ϕ 8/ ϕ 12

Example of combination

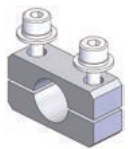

Slide bracket • ϕ 12

Order code No.	131145
TYPE	N01863-201

● Weight : 8.5g

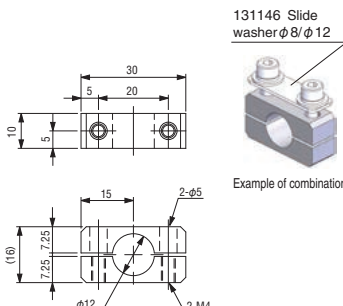

131146 Slide washer ϕ 8/ ϕ 12

Example of combination

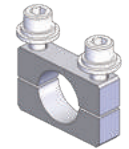

Slide bracket • ϕ 20

Order code No.	131149
TYPE	N01863-205

● Weight : 15.0g

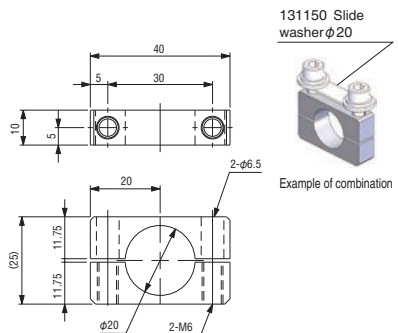

131150 Slide washer ϕ 20

Example of combination

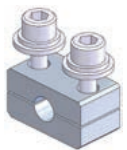

Slide bracket • W • ϕ 8

Order code No.	131217
TYPE	N01863-113

● Weight : 12.0g

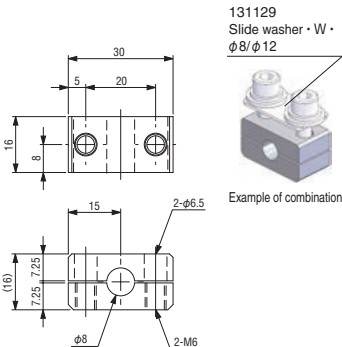

131129 Slide washer • W • ϕ 8/ ϕ 12

Example of combination

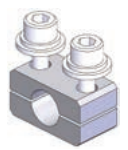

Slide bracket • W • ϕ 12

Order code No.	131128
TYPE	N01863-101

● Weight : 13.3g

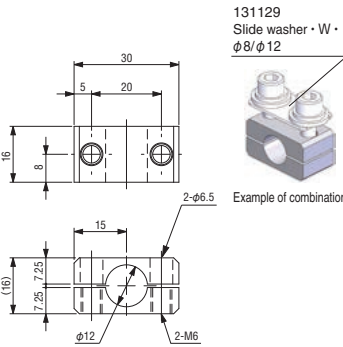

131129 Slide washer • W • ϕ 8/ ϕ 12

Example of combination



Slide bracket • W • ϕ 20

Order code No.	131134
TYPE	N01863-111

● Weight : 26.2g

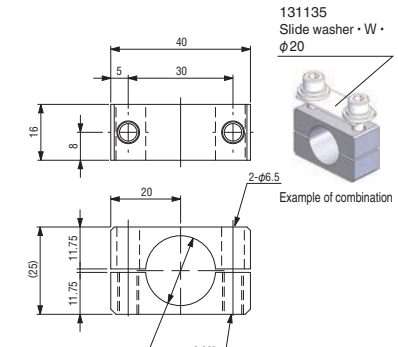

131135 Slide washer • W • ϕ 20

Example of combination

Quick Chuck Change

- Quick Chuck Change Manual
- Quick Chuck Change Manual (OM Type)
- Tool Changer
- Automated Hand Exchange System

Grip

- Mini Cylinder
- Accessories for Mini Cylinder
- Container Cylinders
- Accessories for Container Cylinder
- Grippers
- Rubber Material / Grip Pad

Suction

- Suction Cups
- Suction Stems
- Pad in Pad

- Vacuum Gripper

- Air Ejector / Filter / Check Valve
- Ultra Small Part Take Out
- Vacuum Generator Unit

Cut

- Air Nipper (Small-Medium)
- Air Nipper (Large)

Frame / Module

- Jungle Gym

- Let's Joint

- Rectangular Tube

- Base Aluminum Material

- Sliding Chuck

Pneumatic Components / Sensors

- Pneumatic Components
- Sensors / Multi AND Board
- PCIO Communication Unit

Lightweight Parts Series

- Frame / Section / Resin Cylinders / Pads / Resin Manifolds

By Industry

- Logistics - Palletizing / Sheet Metal - Stamping - Metal Fabrication

- Assembling Tools

- Tool / Jig

- Information
- Various Products Information

Jungle Gym Series Parts

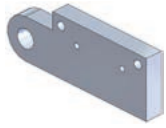

Sensor bracket • ϕ 12

Order code No.	131189
TYPE	N01867-101

- Weight : 9.2g
- Limit switch \rightarrow **6-18** ,
- Photo sensor \rightarrow **6-22** could be installed.

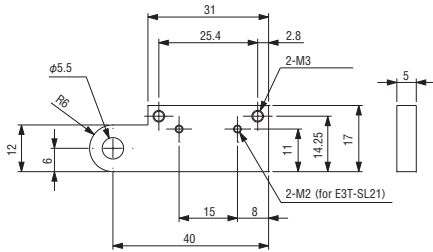

Sensor Mounting Example

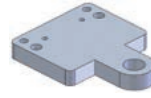
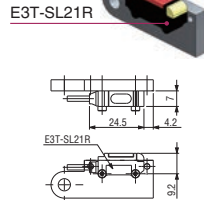

Sensor bracket

Order code No.	131077
TYPE	N01915-201

- Weight : 12.6g
- Limit switch \rightarrow **6-18** ,
- Photo sensor \rightarrow **6-22** could be installed.

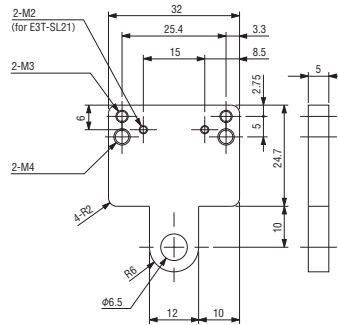

Sensor Mounting Example

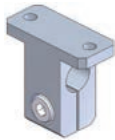

Chuck bracket • TH • ϕ 8

Order code No.	131188
TYPE	N01866-502

- Weight : 8.6g
- If base frame ϕ 8 is used, this product may be loosened and rotated.
- Check the length of mounting bolt

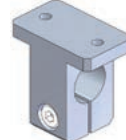
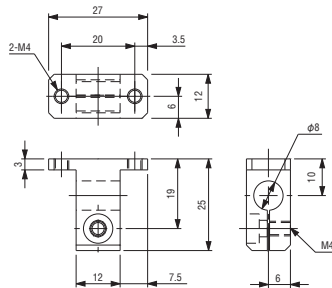

Chuck bracket • TH • ϕ 12

Order code No.	131187
TYPE	N01866-501

- Weight : 18.3g
- Check the length of mounting bolt

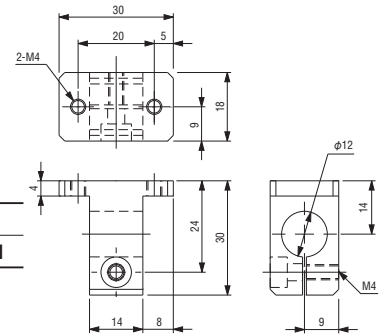

Chuck bracket • ϕ 12

Order code No.	131067
TYPE	N01915-105

- Weight : 19.6g

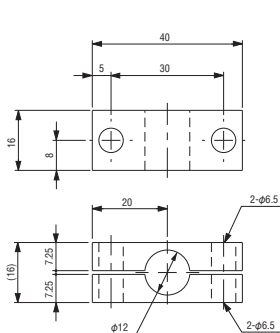

Nipper bracket • A

Order code No.	131078
TYPE	N01915-301

- Weight : 208.8g

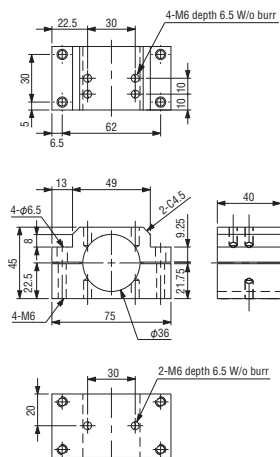

Nipper bracket • B

Order code No.	131216
TYPE	N01915-302

- Weight : 198.4g

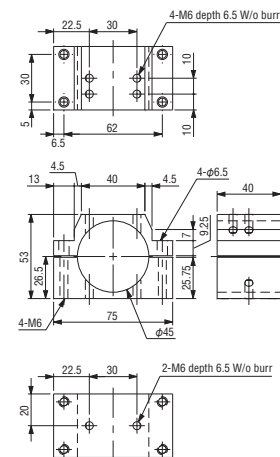

Nipper bracket • C

Order code No.	131080
TYPE	N01915-303

- Weight : 241.3g

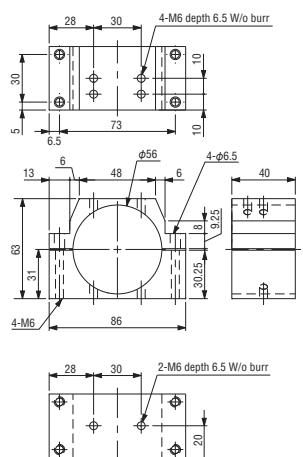

Jungle Gym Series Parts

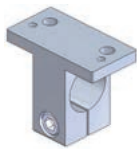

Bracket • TH • φ20 • for MCD

Order code No.	131183
TYPE	N01866-303

- Weight : 40.6g
- Check the length of mounting bolt for mini cylinder.
- There may be interference between pipe and bolt when you attach mini container cylinder.

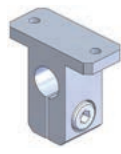
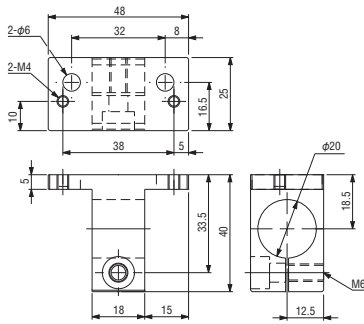

Bracket • TV • φ8 • for UMCD

Order code No.	131185
TYPE	N01866-402

- Weight : 8.7g
- If base frame φ8 is used, this product may be loosened and rotated.

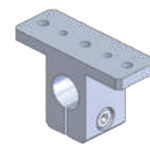
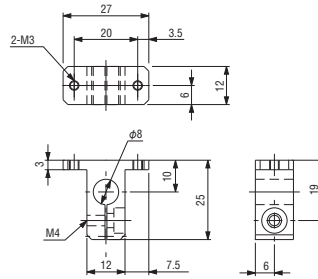

Bracket • TV • φ12 • for MCD

Order code No.	131184
TYPE	N01866-401

- Weight : 25.6g

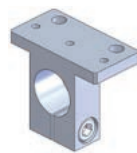
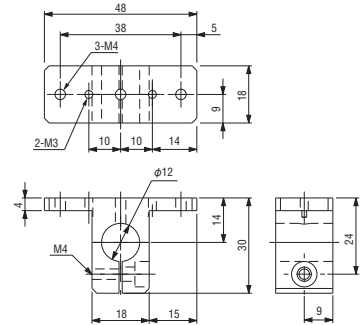

Bracket • TV • φ20 • for MCD

Order code No.	131186
TYPE	N01866-403

- Weight : 35.9g

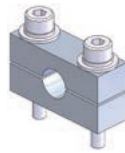
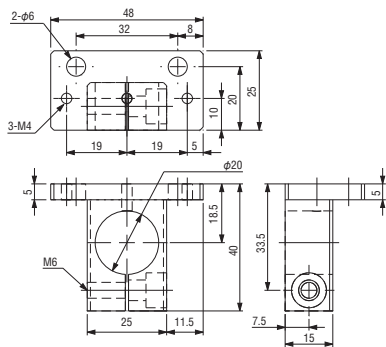

Bracket • φ8

Order code No.	131073
TYPE	N01915-111

- Weight : 10.0g

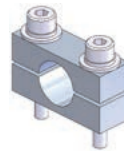
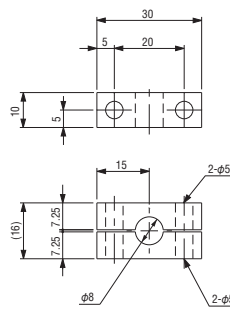

Bracket • φ12

Order code No.	131071
TYPE	N01915-109

- Weight : 8.2g

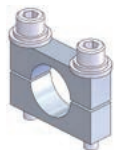
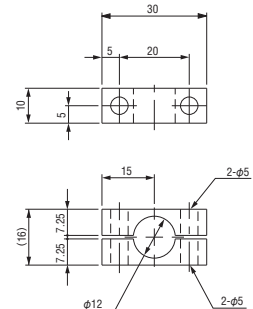

Bracket • φ20

Order code No.	131072
TYPE	N01915-110

- Weight : 16.1g

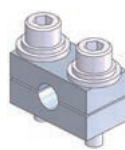
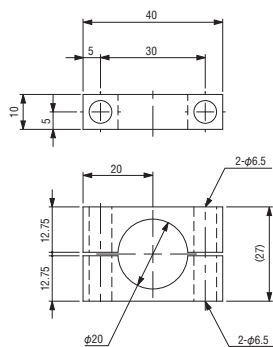

Bracket • W • φ8

Order code No.	131070
TYPE	N01915-108

- Weight : 15.8g

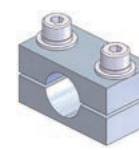
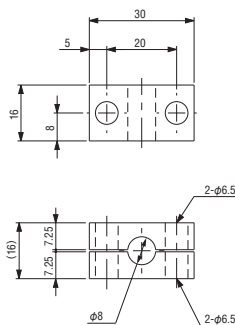

Bracket • W • φ12

Order code No.	131068
TYPE	N01915-106

- Weight : 12.9g

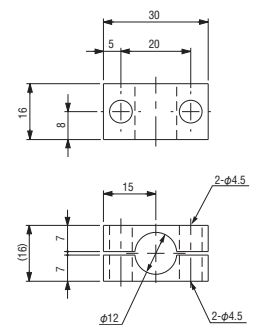

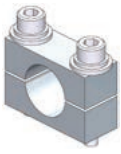

Bracket • W • $\phi 20$

Order code No.	131069
TYPE	N01915-107

● Weight : 28.6g

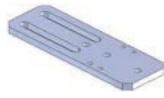
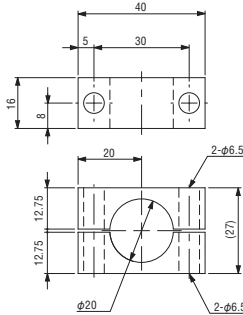

Bracket • NCON

Order code No.	131083
TYPE	N01915-401

● Weight : 153.7g
● for NCON-20W, 40W, 80W

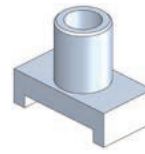
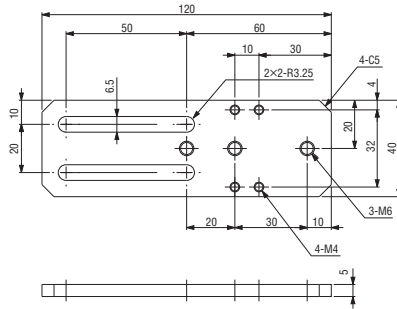

Rotation bracket • $\phi 20$

Order code No.	131064
TYPE	N01915-101

● Weight : 8.9g

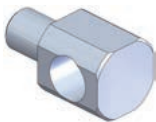
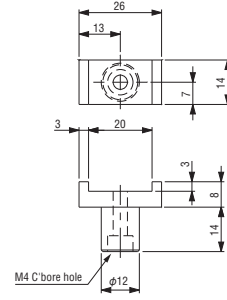

Rotation bracket • M10 • 8A

Order code No.	131434
TYPE	N01864-305

● Weight : 7.0g

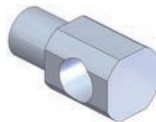
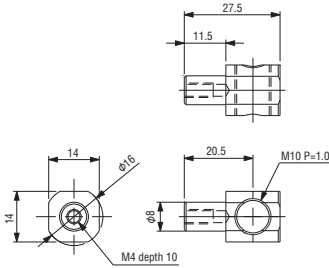

Rotation bracket • M12 • 12A

Order code No.	131173
TYPE	N01864-306

● Weight : 12.9g

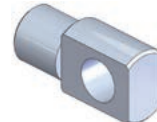
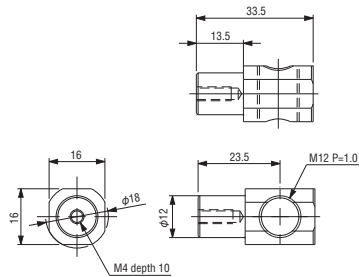

Rotation bracket • M17 • 20A

Order code No.	131174
TYPE	N01864-307

● Weight : 59.3g

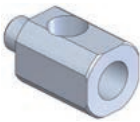
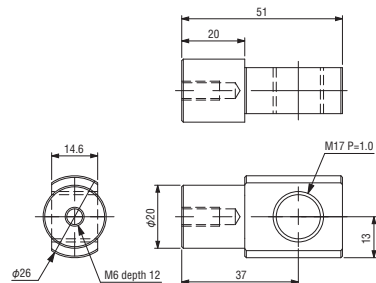

Rotation bracket • PT1/8 • 8A

Order code No.	131175
TYPE	N01864-401

● Weight : 11.8g

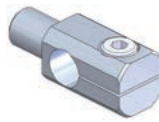
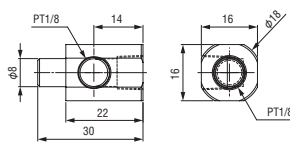

Rotation bracket • $\phi 8$ • 8A

Order code No.	131170
TYPE	N01864-303

● Weight : 6.6g

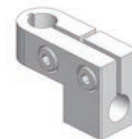
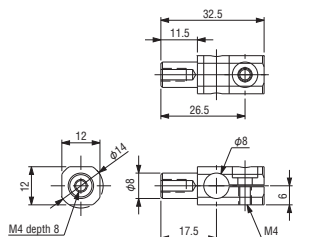

Rotation bracket • $\phi 8$ • 8B

Order code No.	131606
TYPE	N01864-103A

● Weight : 18.0g

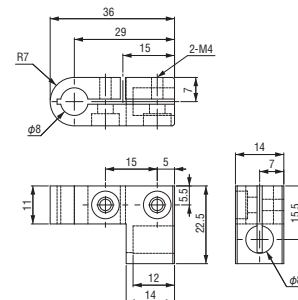

Quick Chuck Change

Quick Chuck Change Manual

Quick Chuck Change Manual (OM Type)

Tool Changer

Automated Hand Exchange System

Grip

Mini Cylinder

Accessories for Mini Cylinder

Container Cylinders

Accessories for Container Cylinder

Grippers

Rubber Material / Grip Pad

Suction

Suction Cups

Suction Stems

Pad in Pad

Vacuum Gripper

Air Ejector / Filter / Check Valve

Ultra Small Part Take Out

Vacuum Generator Unit

Cut

Air Nipper (Small-Medium)

Air Nipper (Large)

Frame / Module

Jungle Gym

Let's Joint

Rectangular Tube

Base Aluminum Material

Sliding Chuck

Pneumatic Components / Sensors

Pneumatic Components

Sensors / Multi AND Board

PCIO Communication Unit

Lightweight Parts Series

Frame / Suction / Resin Cylinders / Pads / Resin Manifolds

By Industry

Logistics-Palletizing/Sheet Metal-Stamping-Metal Fabrication

Assembling Tools

Tool / Jig

Information

Various Products Information

Jungle Gym Series Parts

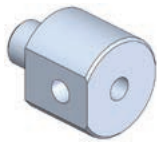

**Rotation bracket •
φ 8 • M5A**

Order code No.	131164
TYPE	N01864-202

● Weight : 10.0g

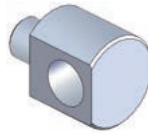
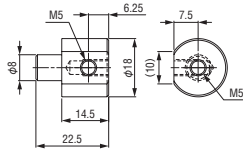

**Rotation bracket •
φ 8 • M10A**

Order code No.	131435
TYPE	N01864-201

● Weight : 8.0g

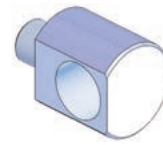
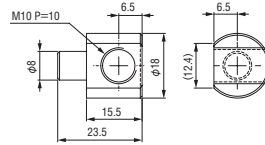

**Rotation bracket •
φ 8 • M12A**

Order code No.	131433
TYPE	N01864-205

● Weight : 7.6g

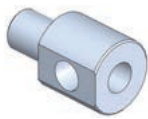
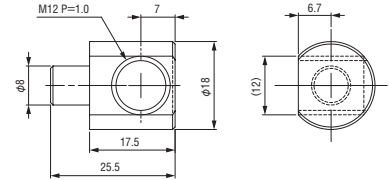

**Rotation bracket •
φ 12 • PT1/8A**

Order code No.	131166
TYPE	N01864-204

● Weight : 24.6g

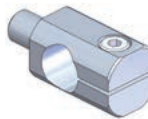
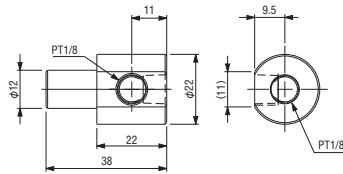

**Rotation bracket •
φ 12 • 8A**

Order code No.	131169
TYPE	N01864-302

● Weight : 11.9g

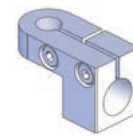
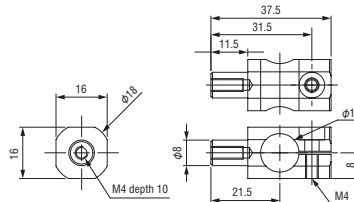

**Rotation bracket •
φ 12 • 8B**

Order code No.	131600
TYPE	N01864-101A

● Weight : 24.0g

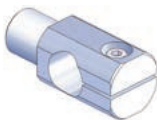
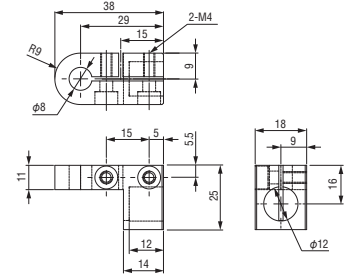

**Rotation bracket •
φ 12 • 12A**

Order code No.	131168
TYPE	N01864-301

● Weight : 14.6g

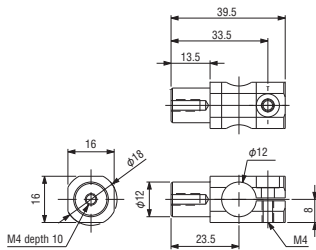

**Rotation bracket •
φ 12 • 12AL**

Order code No.	131567
TYPE	N01864-301L

● Weight : 15.0g

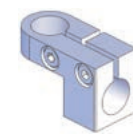
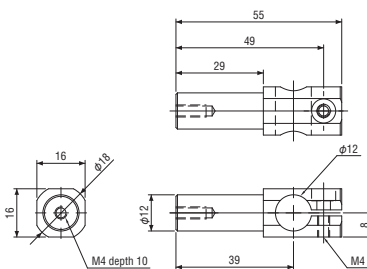

**Rotation bracket •
φ 12 • 12B**

Order code No.	131605
TYPE	N01864-102A

● Weight : 22.0g

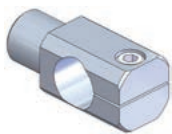
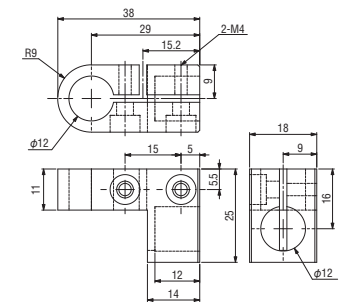

**Rotation bracket •
φ 20 • 20A**

Order code No.	131171
TYPE	N01864-304

● Weight : 50.7g

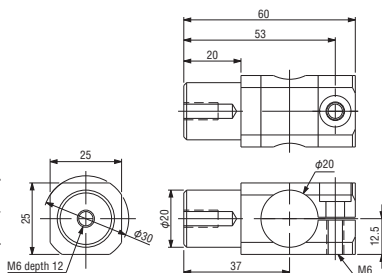

**Rotation bracket •
φ 20 • 20AL**

Order code No.	131568
TYPE	N01864-304L

● Weight : 80.0g

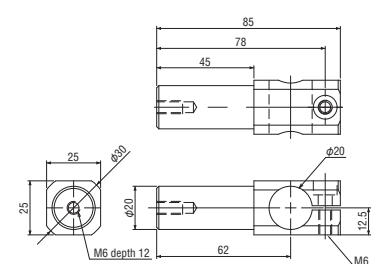

Suction rotate # A • $\phi 8$

Order code No.	131194
TYPE	N01868-104

● Weight : 11.6g

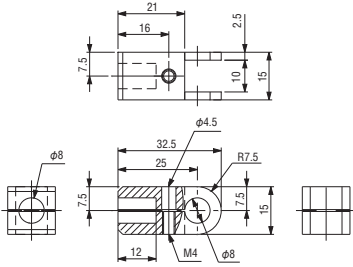

Suction rotate # A • $\phi 12$

Order code No.	131191
TYPE	N01868-101

● Weight : 17.1g

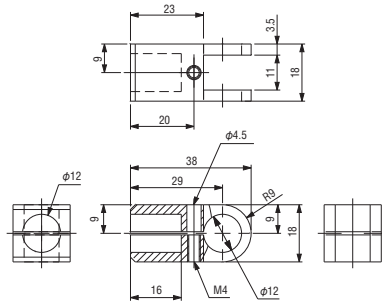

Suction rotate # B • M5 • $\phi 12$

Order code No.	131192
TYPE	N01868-102

● Weight : 4.8g

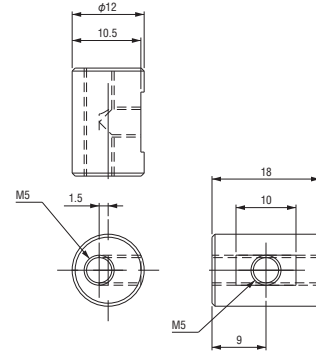

Slide bracket 40 • M3

Order code No.	131158
TYPE	N01863-214

● Weight : 6.5g

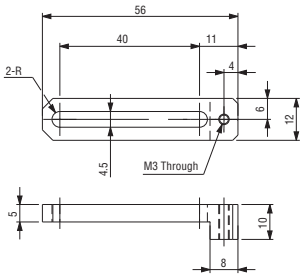

Slide bracket 40 • M5

Order code No.	131147
TYPE	N01863-203

● Weight : 8.6g

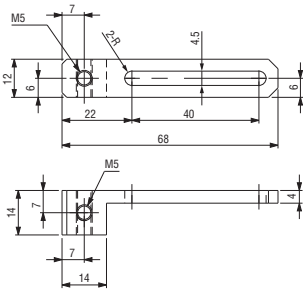

Slide bracket 40 • M6

Order code No.	131156
TYPE	N01863-212

● Weight : 10.3g ● M6 (fine)

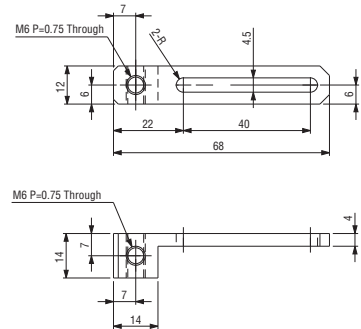

Slide bracket 40 • PT1/8

Order code No.	131154
TYPE	N01863-210

● Weight : 12.0g

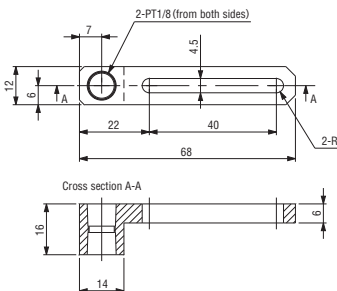

Slide bracket 40 • W • M10

Order code No.	131139
TYPE	N01863-117

● Weight : 10.5g ● M10 (fine)

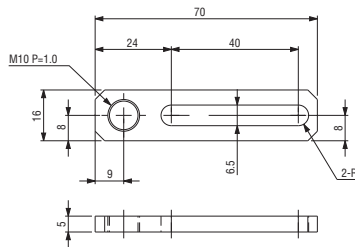

Slide bracket 40 • W • M12

Order code No.	131140
TYPE	N01863-118

● Weight : 10.6g ● M12 (fine)

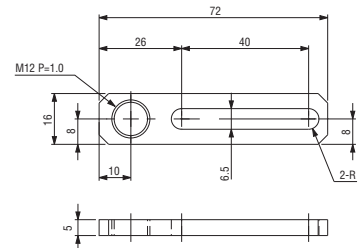

Quick Chuck Change

- Quick Chuck Change Manual
- Quick Chuck Change Manual (OM Type)
- Tool Changer
- Automated Hand Exchange System

Grip

- Mini Cylinder
- Accessories for Mini Cylinder
- Container Cylinders
- Accessories for Container Cylinder
- Grippers
- Rubber Material / Grip Pad

Suction

- Suction Cups
- Suction Stems
- Pad in Pad
- Vacuum Gripper
- Air Ejector / Filter / Check Valve
- Ultra Small Part Take Out
- Vacuum Generator Unit

Cut

- Air Nipper (Small-Medium)
- Air Nipper (Large)

Frame / Module

- Jungle Gym
- Let's Joint
- Rectangular Tube
- Base Aluminum Material
- Sliding Chuck

Pneumatic Components / Sensors

- Pneumatic Components
- Sensors / Multi AND Board
- PCIO Communication Unit

Lightweight Parts Series

- Frame / Section / Resin Cylinders / Pads / Resin Manifolds

By Industry

- Logistics-Palletizing/Sheet Metal-Stamping-Metal Fabrication

Assembling Tools

- Tool / Jig

Information

- Various Products Information

Jungle Gym Series Parts

Slide bracket 40 • W • M17

Order code No.	131143
TYPE	N01863-122

● Weight : 21.2g ● M17 (fine)

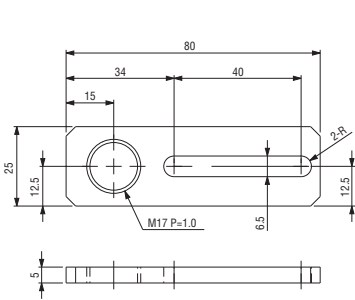

Slide bracket 40 • W • φ8

Order code No.	131152
TYPE	N01863-208

● Weight : 16.7g

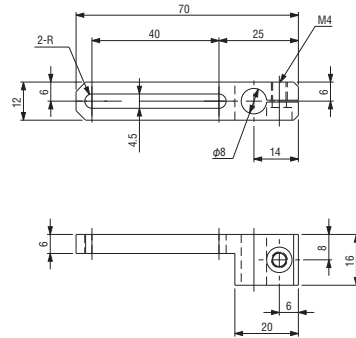

Slide bracket 40 • W • φ8

Order code No.	131131
TYPE	N01863-106

● Weight : 22.7g

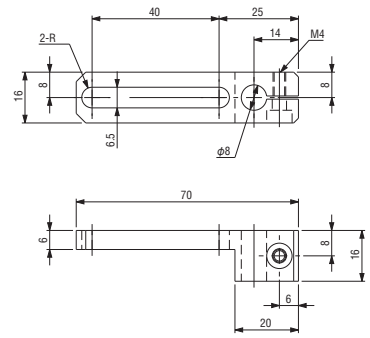

Slide bracket 40 • W • φ12

Order code No.	131132
TYPE	N01863-107

● Weight : 20.0g

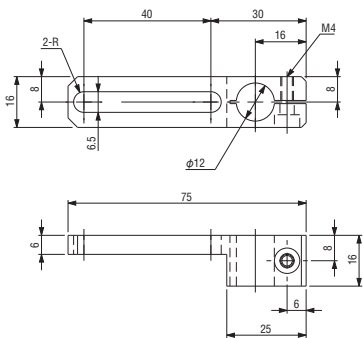

Slide bracket 40 • W • φ20

Order code No.	131137
TYPE	N01863-114

● Weight : 40.0g

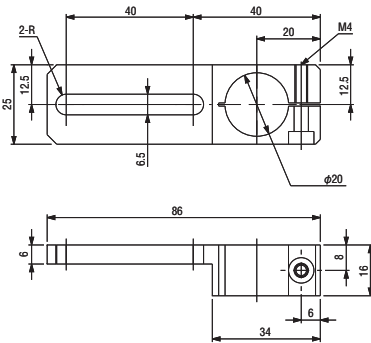

Slide bracket 40 • T • W • φ8

Order code No.	230051
TYPE	XL0005-102

● Weight : 20.7g

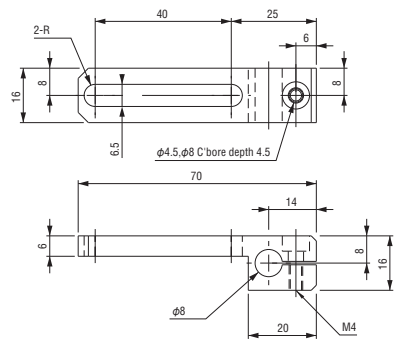

Slide bracket 40 • T • φ8

Order code No.	230056
TYPE	XL0005-107

● Weight : 16.2g

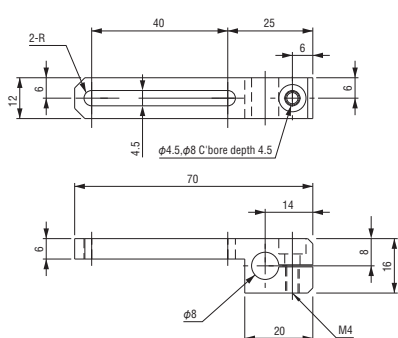

Slide bracket 40 • T • φ12

Order code No.	230052
TYPE	XL0005-103

● Weight : 21.4g

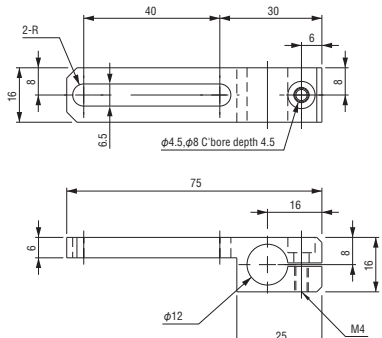

Slide bracket 40 • T • φ20

Order code No.	230054
TYPE	XL0005-105

● Weight : 54.4g

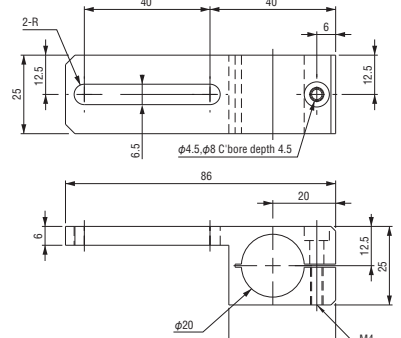

Slide bracket 70 • M3

Order code No.	131159
TYPE	N01863-217

● Weight : 9.6g

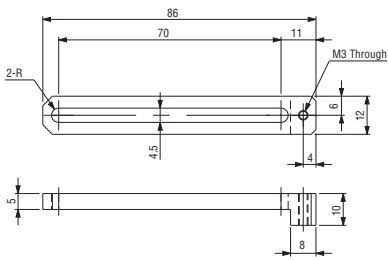

Slide bracket 70 • M5

Order code No.	131148
TYPE	N01863-204

● Weight : 13.2g

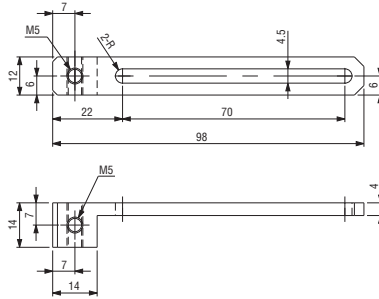

Slide bracket 70 • M6

Order code No.	131157
TYPE	N01863-213

● Weight : 12.8g ● M6 (fine)

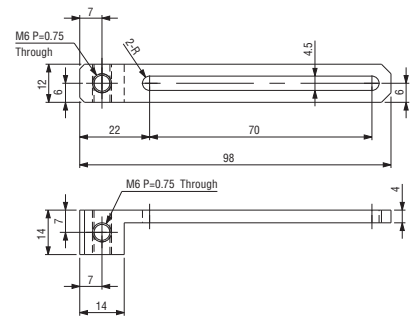

Slide bracket 70 • PT1/8

Order code No.	131155
TYPE	N01863-211

● Weight : 15.8g

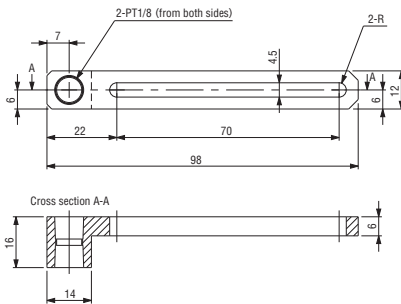

Slide bracket 70 • W • M10

Order code No.	131141
TYPE	N01863-120

● Weight : 14.5g ● M10 (fine)

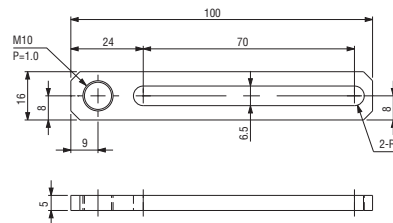

Slide bracket 70 • W • M12

Order code No.	131142
TYPE	N01863-121

● Weight : 14.6g ● M12 (fine)

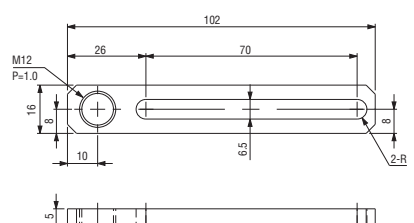

Slide bracket 70 • W • M17

Order code No.	131144
TYPE	N01863-124

● Weight : 29.0g ● M17 (fine)

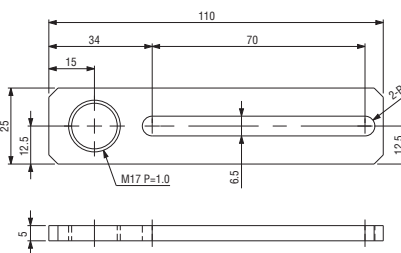

Slide bracket 70 • φ8

Order code No.	131153
TYPE	N01863-209

● Weight : 20.5g

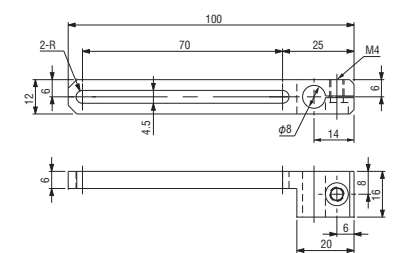

Slide bracket 70 • W • φ8

Order code No.	131133
TYPE	N01863-110

● Weight : 27.4g

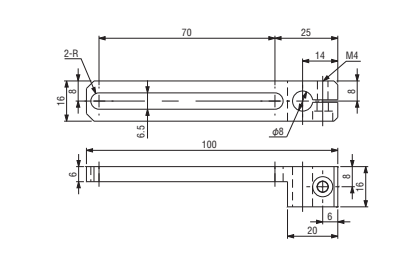

Quick Chuck Change

- Quick Chuck Change Manual
- Quick Chuck Change Manual (OM Type)
- Tool Changer
- Automated Hand Exchange System

Grip

- Mini Cylinder
- Accessories for Mini Cylinder
- Container Cylinders
- Accessories for Container Cylinder
- Grippers
- Rubber Material / Grip Pad

Suction

- Suction Cups
- Suction Stems
- Pad in Pad
- Vacuum Gripper
- Air Ejector / Filter / Check Valve
- Ultra Small Part Take Out
- Vacuum Generator Unit

Cut

- Air Nipper (Small-Medium)
- Air Nipper (Large)

Frame / Module

Jungle Gym

- Let's Joint
- Rectangular Tube
- Base Aluminum Material
- Sliding Chuck

Pneumatic Components / Sensors

- Pneumatic Components
- Sensors / Multi AND Board
- PCIO Communication Unit

Lightweight Parts Series

- Frame / Suction / Resin Cylinders / Pads / Resin Manifolds

By Industry

- Logistics - Palletizing/Sheet Metal-Stamping-Metal Fabrication

Assembling Tools

- Tool / Jig

Information

- Various Products Information

Jungle Gym Series Parts

**Slide bracket 70 •
W • ϕ 12**

Order code No.	131130
TYPE	N01863-103

● Weight : 24.7g

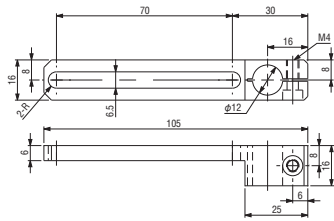

**Slide bracket 70 •
W • ϕ 20**

Order code No.	131138
TYPE	N01863-115

● Weight : 48.3g

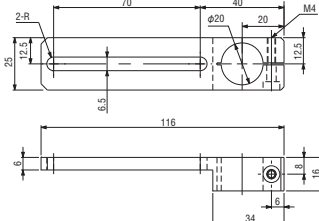

**Slide bracket 70 •
T • W • ϕ 8**

Order code No.	230053
TYPE	XL0005-104

● Weight : 25.4g

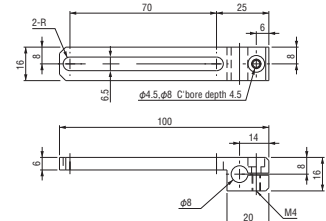

**Slide bracket 70 •
T • ϕ 8**

Order code No.	230057
TYPE	XL0005-108

● Weight : 20.0g

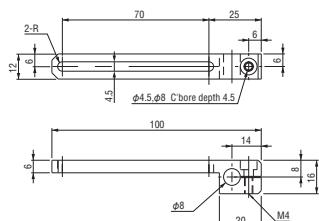

**Slide bracket 70 •
T • ϕ 12**

Order code No.	230050
TYPE	XL0005-101

● Weight : 26.2g

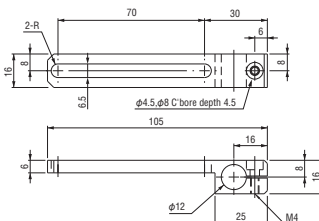

**Slide bracket 70 •
T • ϕ 20**

Order code No.	230055
TYPE	XL0005-106

● Weight : 63.7g

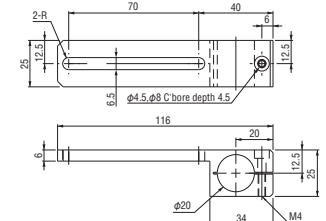

**Slide washer •
 ϕ 8 / ϕ 12**

Order code No.	131146
TYPE	N01863-202

● Weight : 1.0g

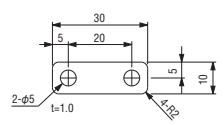

**Slide washer •
W • ϕ 8 / ϕ 12**

Order code No.	131129
TYPE	N01863-102

● Weight : 1.7g

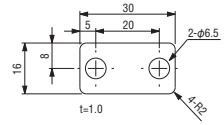

**Slide washer •
 ϕ 20**

Order code No.	131150
TYPE	N01863-206

● Weight : 1.4g

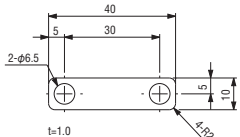

**Slide washer •
W • ϕ 20**

Order code No.	131135
TYPE	N01863-112

● Weight : 2.3g

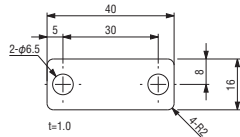

**Nut plate
for slide bracket**

Order code No.	023197
TYPE	CP-076

● Weight : 15.0g

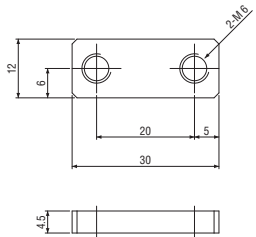



Bushing nut • $\phi 8 \cdot M5$

Order code No.	131200
TYPE	N01868-401

● Weight : 1.4g

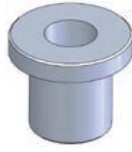
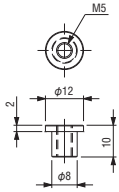

Bushing nut • $\phi 8 \cdot M6$

Order code No.	131206
TYPE	N01868-410

● Weight : 1.3g ● M6 (fine)

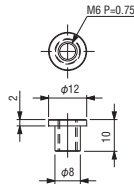

Bushing nut • $\phi 12 \cdot M5$

Order code No.	131202
TYPE	N01868-403

● Weight : 5.5g

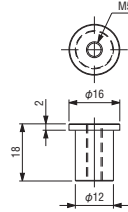

Bushing nut • $\phi 12 \cdot M10$

Order code No.	131201
TYPE	N01868-402

● Weight : 3.0g ● M10 (fine)

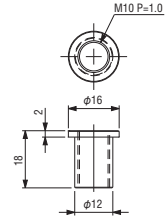

Bushing nut • $\phi 12 \cdot PT1/8$

Order code No.	131207
TYPE	N01868-411

● Weight : 1.7g

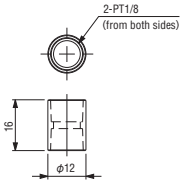

Bushing nut • $\phi 20 \cdot M12$

Order code No.	131205
TYPE	N01868-409

● Weight : 12.3g ● M12 (fine)

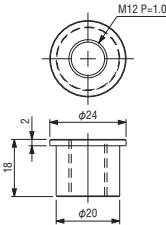

Bushing nut • $\phi 20 \cdot PT1/8$

Order code No.	131199
TYPE	N01868-305

● Weight : 40.0g

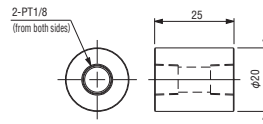

Bushing nut • $M5-M3$

Order code No.	131204
TYPE	N01868-407

● Weight : 2.6g

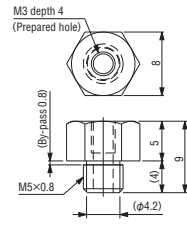

Bushing • $\phi 12 \phi 8$

Order code No.	131196
TYPE	N01868-301

● Weight : 2.8g

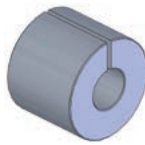
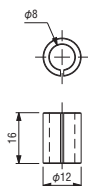

Bushing • $\phi 20 \phi 8$

Order code No.	131197
TYPE	N01868-302

● Weight : 11.6g

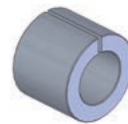
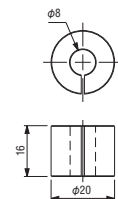

Bushing • $\phi 20 \phi 12$

Order code No.	131198
TYPE	N01868-303

● Weight : 8.9g

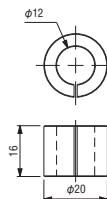

Quick Chuck Change

- Quick Chuck Change Manual
- Quick Chuck Change Manual (OM Type)
- Tool Changer
- Automated Hand Exchange System

Grip

- Mini Cylinder
- Accessories for Mini Cylinder
- Container Cylinders
- Accessories for Container Cylinder
- Grippers
- Rubber Material / Grip Pad

Suction

- Suction Cups
- Suction Stems
- Pad in Pad

Vacuum Gripper

- Air Ejector / Filter / Check Valve
- Ultra Small Part Take Out
- Vacuum Generator Unit

Cut

- Air Nipper (Small-Medium)
- Air Nipper (Large)

Frame / Module

Jungle Gym

- Let's Joint

Rectangular Tube

Base Aluminum Material

Sliding Chuck

Pneumatic Components / Sensors

Pneumatic Components

Sensors / Multi AND Board

PCIO Communication Unit

Lightweight Parts Series

Frame / Section / Resin Cylinders / Pads / Resin Manifolds

By Industry

- Logistics-Palletizing/Sheet Metal-Stamping-Metal Fabrication

Assembling Tools

- Tool / Jig

Information

- Various Products Information

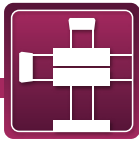

Base Frame Module

Modularized Robot hand parts for jungle gym

● Pipe lengths of SUS pipes specified in each configuration module and components are different from that of base frame.

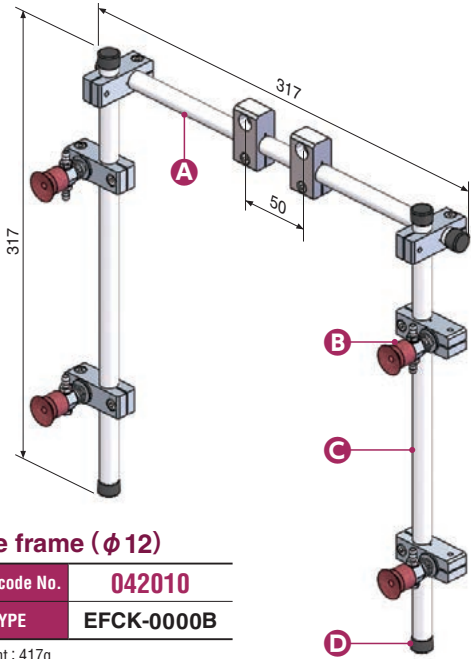

Base frame (φ 12)

Order code No.	042010
TYPE	EFCK-0000B

● Weight : 417g

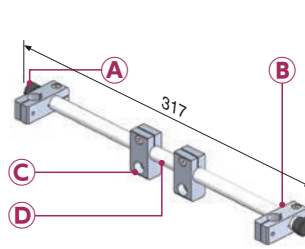

components of EFCK-0000B...**A**

Order code No.	042011
TYPE	EFCK-0001B

● Weight : 148g

Configuration parts	TYPE	Order code No.	No. of uses	Details
A Pipe end cap · φ 12	R-CAP-12	171339	2	5-9
B Cross connector · φ 12 φ 12	N01861-202	131099	2	5-10
C Attachment bracket · φ 12 · M6	N01862-201	131118	2	5-13
D Jungle gym SUS pipe φ 12	12*0.6*500	271527	1	5-8

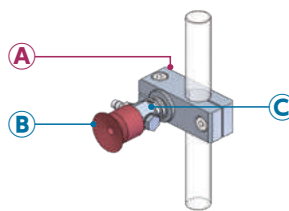

components of EFCK-0000B...**B**

Order code No.	090158
TYPE	JSM-004

● Weight : 39g

Configuration module	TYPE	Order code No.	No. of uses	Details
A Base frame for jungle gym	EFCK-0001B	042011	1	5-26
B Suction module for jungle gym (φ 12)	JSM-004	090158	4	5-26
C Jungle gym SUS pipe φ 12	12*0.6*1000	271528	1	5-8
D Pipe end cap · φ 12	R-CAP-12	171339	4	5-9

Configuration parts	TYPE	Order code No.	No. of uses	Details
A Cross connector · φ 12 φ 12	N01861-202	131099	1	5-10
B Suction cups (standard/silicon/brown)	VAPH-20C	210194	1	3-4
C Suction stem for small	VFIL1-S-5-P12	211006	1	3-26

Base frame for jungle gym

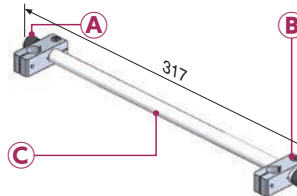

Order code No.	042012
TYPE	EFCK-0002B

● Weight : 96g

Base frame for jungle gym

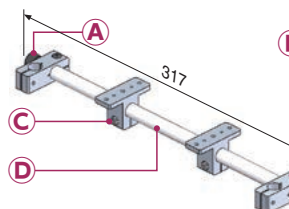

Order code No.	042013
TYPE	EFCK-0003B

● Weight : 151g

Configuration parts	TYPE	Order code No.	No. of uses	Details
A Pipe end cap · φ 12	R-CAP-12	171339	2	5-9
B Cross connector · φ 12 φ 12	N01861-202	131099	2	5-10
C Jungle gym SUS pipe φ 12	12*0.6*500	271527	1	5-8

Configuration parts	TYPE	Order code No.	No. of uses	Details
A Pipe end cap · φ 12	R-CAP-12	171339	2	5-9
B Cross connector · φ 12 φ 12	N01861-202	131099	2	5-10
C Bracket · TV · φ 12 · for MCD	N01866-401	131184	2	5-18
D Jungle gym SUS pipe φ 12	12*0.6*500	271527	1	5-8

Base frame for jungle gym

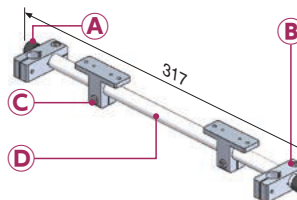

Order code No.	042014
TYPE	EFCK-0004B

● Weight : 144g

Base frame for jungle gym

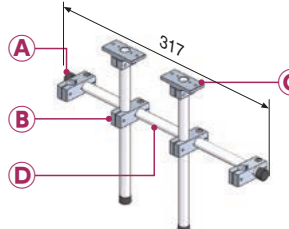

Order code No.	042015
TYPE	EFCK-0005B

● Weight : 247g

Configuration parts	TYPE	Order code No.	No. of uses	Details
A Pipe end cap · φ 12	R-CAP-12	171339	2	5-9
B Cross connector · φ 12 φ 12	N01861-202	131099	2	5-10
C Bracket · TH · φ 12 · for MCD	N01866-301	131181	2	5-17
D Jungle gym SUS pipe φ 12	12*0.6*500	271527	1	5-8

Configuration parts	TYPE	Order code No.	No. of uses	Details
A Pipe end cap · φ 12	R-CAP-12	171339	4	5-9
B Cross connector · φ 12 φ 12	N01861-202	131099	4	5-10
C Bracket · T · φ 12 · for MCD	N01866-101	131176	2	5-17
D Jungle gym SUS pipe φ 12	12*0.6*1000	271528	1	5-8

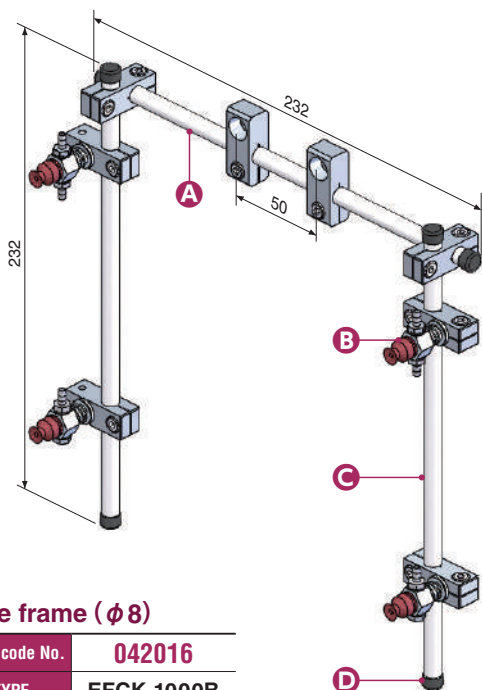

Base frame (φ8)

Order code No.	042016
TYPE	EFCK-1000B

● Weight : 202g

Configuration module	TYPE	Order code No.	No. of uses	Details
A Base frame for jungle gym	EFCK-1001B	042017	1	5-27
B Suction module for jungle gym (φ8)	JSM-001	090155	4	5-27
C Jungle gym SUS pipe φ8	8*0.6*500	340905	1	5-8
D Pipe end cap · φ8	R-CAP-8	171338	4	5-9

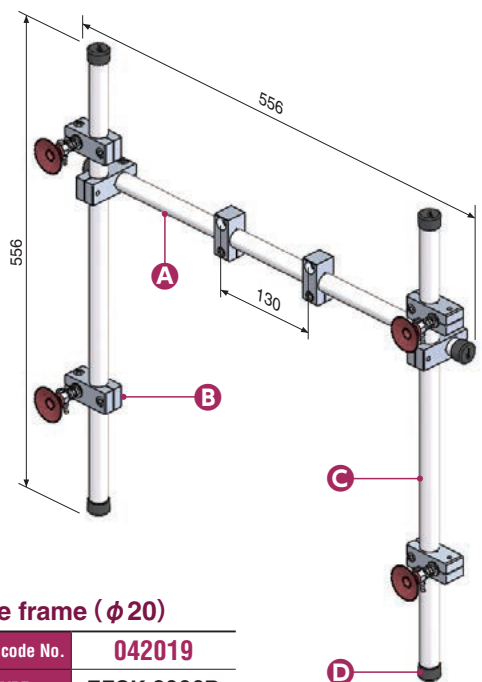

Base frame (φ20)

Order code No.	042019
TYPE	EFCK-2000B

● Weight : 1,293g

Configuration module	TYPE	Order code No.	No. of uses	Details
A Base frame for jungle gym	EFCK-2001B	042020	1	5-27
B Suction module for jungle gym (φ20)	JSM-008	090162	4	5-27
C Jungle gym SUS pipe φ20	20*0.8*1500	281814	1	5-8
D Pipe end cap · φ20	R-CAP-20	171340	4	5-9

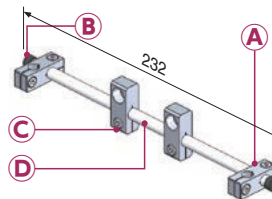

components of EFCK-1000B...

Order code No.	042017
TYPE	EFCK-1001B

● Weight : 72g

Configuration parts	TYPE	Order code No.	No. of uses	Details
A Cross connector · φ8φ8	N01861-207	131102	2	5-10
B Pipe end cap · φ8	R-CAP-8	171338	2	5-9
C Attachment bracket · φ8 · M6	N01862-205	131121	2	5-13
D Jungle gym SUS pipe φ8	8*0.6*500	340905	1	5-8

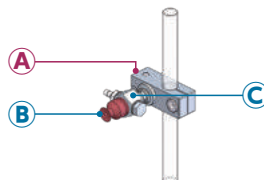

components of EFCK-1000B...

Order code No.	090155
TYPE	JSM-001

● Weight : 21g

Configuration parts	TYPE	Order code No.	No. of uses	Details
A Cross connector · φ8φ8	N01861-207	131102	1	5-10
B Suction cups (standard/silicon/brown)	VAPH-8C	210191	1	3-4
C Suction stem for mini	VFIL2-SS-5-P8	211030	1	3-23

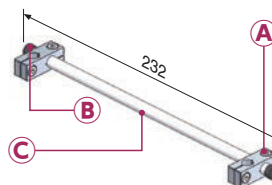

Base frame for jungle gym

Order code No.	042018
TYPE	EFCK-1002B

● Weight : 47g

Configuration parts	TYPE	Order code No.	No. of uses	Details
A Cross connector · φ8φ8	N01861-207	131102	2	5-10
B Pipe end cap · φ8	R-CAP-8	171338	2	5-9
C Jungle gym SUS pipe φ8	8*0.6*500	340905	1	5-8

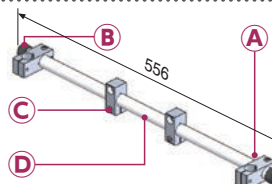

components of EFCK-2000B...

Order code No.	042020
TYPE	EFCK-2001B

● Weight : 452g

Configuration parts	TYPE	Order code No.	No. of uses	Details
A Cross connector · φ20φ20	N01861-206	131101	2	5-10
B Pipe end cap · φ20	R-CAP-20	171340	2	5-9
C Attachment bracket · φ20 · M8	N01862-214	131226	2	5-14
D Jungle gym SUS pipe φ8	20*0.8*1000	281813	1	5-8

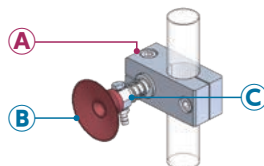

components of EFCK-2000B...

Order code No.	090162
TYPE	JSM-008

● Weight : 102g

Configuration parts	TYPE	Order code No.	No. of uses	Details
A Cross connector · φ20φ12	N01861-204	131100	1	5-10
B Suction cups (standard/silicon/brown)	VAPH-40C	210196	1	3-5
C Suction stem for small	VFIL1-S-5-P12	211006	1	3-26

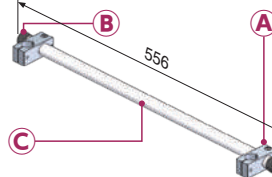

Base frame for jungle gym

Order code No.	042021
TYPE	EFCK-2002B

● Weight : 358g

Configuration parts	TYPE	Order code No.	No. of uses	Details
A Cross connector · φ20φ20	N01861-206	131101	2	5-10
B Pipe end cap · φ20	R-CAP-20	171340	2	5-9
C Jungle gym SUS pipe φ20	20*0.8*1000	281813	1	5-8

Quick Chuck Change

Quick Chuck Change Manual

Quick Chuck Change Manual (OM Type)

Tool Changer

Automated Hand Exchange System

Grip

Mini Cylinder

Accessories for Mini Cylinder

Container Cylinders

Accessories for Container Cylinder

Grippers

Rubber Material / Grip Pad

Suction

Suction Cups

Suction Stems

Pad in Pad

Vacuum Gripper

Air Ejector / Filter / Check Valve

Ultra Small Part Take Out

Vacuum Generator Unit

Cut

Air Nipper (Small-Medium)

Air Nipper (Large)

Frame / Module

Jungle Gym

Let's Joint

Rectangular Tube

Base Aluminum Material

Sliding Chuck

Pneumatic Components / Sensors

Pneumatic Components

Sensors / Multi AND Board

PCIO Communication Unit

Lightweight Parts Series

Frame / Section / Resin Cylinders / Pads / Resin Manifolds

By Industry

Logistics-Palletizing / Sheet Metal-Stamping-Metal Fabrication

Assembling Tools

Tool / Jig

Information

Various Products Information

Change Method of Sales (Change to Single Sale)

▶ Base frame module (φ 8)

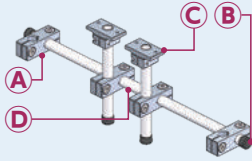

Base frame for jungle gym

Order code No.	041664
TYPE	EFCK-1005

● Weight : 101g

Configuration parts	TYPE	Order code No.	No. of uses	Details
(A) Cross connector · φ 8 φ 8	N01861-207	131102	4	5-10
(B) Pipe end cap · φ 8	R-CAP-8	171338	4	5-9
(C) Bracket · T · φ 8 · for UMCD	N01866-102	131177	2	5-17
(D) Jungle gym SUS pipe φ 8	8*0.6*500	340905	1	5-8

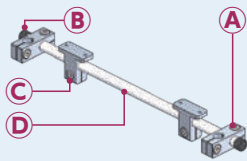

Base frame for jungle gym

Order code No.	041663
TYPE	EFCK-1004

Configuration parts	TYPE	Order code No.	No. of uses	Details
(A) Cross connector · φ 8 φ 8	N01861-207	131102	2	5-10
(B) Pipe end cap · φ 8	R-CAP-8	171338	2	5-9
(C) Bracket · TH · φ 8 · for UMCD	N01866-302	131182	2	5-17
(D) Jungle gym SUS pipe φ 8	8*0.6*500	340905	1	5-8

* Pipe length is 500mm if only SUS pipe φ 8 is ordered.

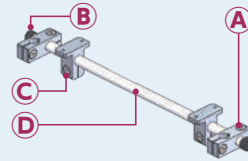

Base frame for jungle gym

Order code No.	041662
TYPE	EFCK-1003

Configuration parts	TYPE	Order code No.	No. of uses	Details
(A) Cross connector · φ 8 φ 8	N01861-207	131102	2	5-10
(B) Pipe end cap · φ 8	R-CAP-8	171338	2	5-9
(C) Bracket · TV · φ 8 · for UMCD	N01866-402	131185	2	5-18
(D) Jungle gym SUS pipe φ 8	8*0.6*500	340905	1	5-8

* Pipe length is 500mm if only SUS pipe φ 8 is ordered.

▶ Base frame module (φ 20)

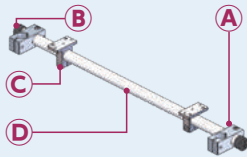

Base frame for jungle gym

Order code No.	041668
TYPE	EFCK-2003

● Weight : 379g

Configuration parts	TYPE	Order code No.	No. of uses	Details
(A) Cross connector · φ 20 φ 20	N01861-206	131101	2	5-10
(B) Pipe end cap · φ 20	R-CAP-20	171340	2	5-9
(C) Bracket · TV · φ 20 · for UMCD	N01866-403	131186	2	5-18
(D) Jungle gym SUS pipe φ 20	20*0.8*1000	281813	1	5-8

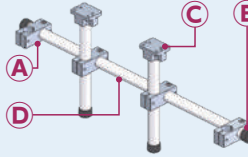

Base frame for jungle gym

Order code No.	041670
TYPE	EFCK-2005

● Weight : 767g

Configuration parts	TYPE	Order code No.	No. of uses	Details
(A) Cross connector · φ 20 φ 20	N01861-206	131101	4	5-10
(B) Pipe end cap · φ 20	R-CAP-20	171340	4	5-9
(C) Bracket · T · φ 20 · for UMCD	N01866-103A	131554	2	5-17
(D) Jungle gym SUS pipe φ 20	20*0.8*1000	281813	1	5-8

▶ Base frame (φ 20)

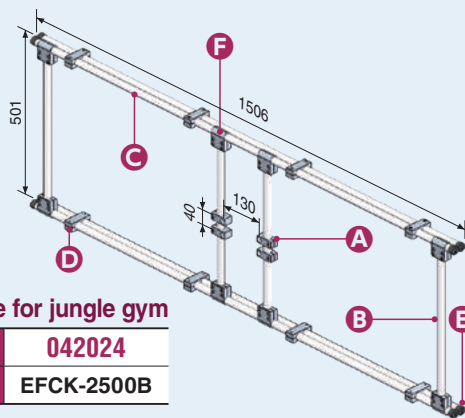

Base frame for jungle gym

Order code No.	042024
TYPE	EFCK-2500B

● Weight : 4,282g

Configuration module	TYPE	Order code No.	No. of uses	Details
(A) Attachment bracket · φ 20 · M8	N01862-214	131226	4	5-14
(B) Jungle gym SUS pipe φ 20	20*0.8*500	281812	4	5-8
(C) Jungle gym SUS pipe φ 20	20*0.8*1500	281814	4	5-8
(D) Parallel connector · φ 20 φ 20	N01861-106	131095	8	5-12
(E) Pipe end cap · φ 20	R-CAP-20	171340	8	5-9
(F) T Connector# 2 · φ 20 φ 20	N01861-405	131114	4	5-12

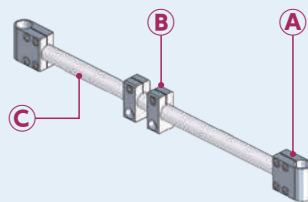

components of EFCK-2500B

Order code No.	041672
TYPE	EFCK-2501

● Weight : 457g

Configuration parts	TYPE	Order code No.	No. of uses	Details
(A) T Connector# 2 · φ 20 φ 20	N01861-405	131114	2	5-12
(B) Attachment bracket · φ 20 · M8	N01862-214	131226	2	5-14
(C) Jungle gym SUS pipe φ 20	20*0.8*500	281812	1	5-8

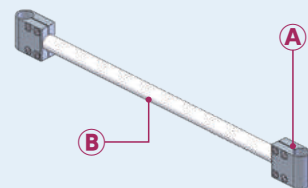

components of EFCK-2500B

Order code No.	041673
TYPE	EFCK-2502

● Weight : 363g

Configuration parts	TYPE	Order code No.	No. of uses	Details
(A) T Connector# 2 · φ 20 φ 20	N01861-405	131114	2	5-12
(B) Jungle gym SUS pipe φ 20	20*0.8*500	281812	1	5-8

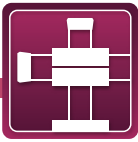

Examples of Robot Chuck Production

Chuck products based on jungle gym parts.

Examples of Chuck products ①

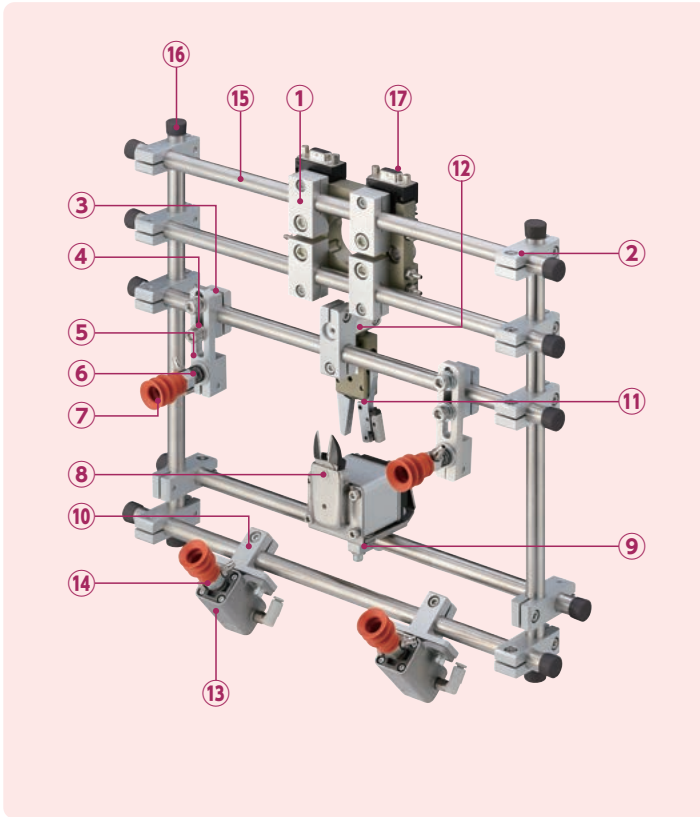

Configuration parts	TYPE	Order code No.	No. of uses
① : Attachment bracket · $\phi 12 \cdot M6$	N01862-201	131118	4
② : Cross connector · $\phi 12 \phi 12$	N01861-202	131099	11
③ : Slide bracket · W · $\phi 12$	N01863-101	131128	2
④ : Slide washer · W · $\phi 8 / \phi 12$	N01863-102	131129	2
⑤ : Slide bracket 40 · W · $\phi 12$	N01863-107	131132	2
⑥ : Suction stem for small	VFIL1-S-5-P12	211006	2
⑦ : Suction cups	VAPH-20C-3	210661	4
⑧ : Mini air nipper · Body · Reverse blade	NW3-35R	131644	1
⑨ : Bracket · W · $\phi 12$	N01915-106	131068	1
⑩ : Bracket · TH · $\phi 12$ · for MCD	N01866-301	131181	2
⑪ : Runner chuck EM (with sensor)	CHE-EM1-12-C	022999	1
⑫ : Rotation bracket · $\phi 12 \cdot 12A$	N01864-301	131168	1
⑬ : Mini cylinder · MCD	MCD1-10	123219	2
⑭ : Suction stem for small · mini cylinder	CP-063B	023195	2
⑮ : Jungle gym SUS pipe $\phi 12$	12 * 0.5 * 500	271527	7
⑯ : Pipe end cap (black) · $\phi 12$	R-CAP-12	171339	14
⑰ : Tool Changer · tool side	OX-SBI	140182	1

Examples of Chuck products ②

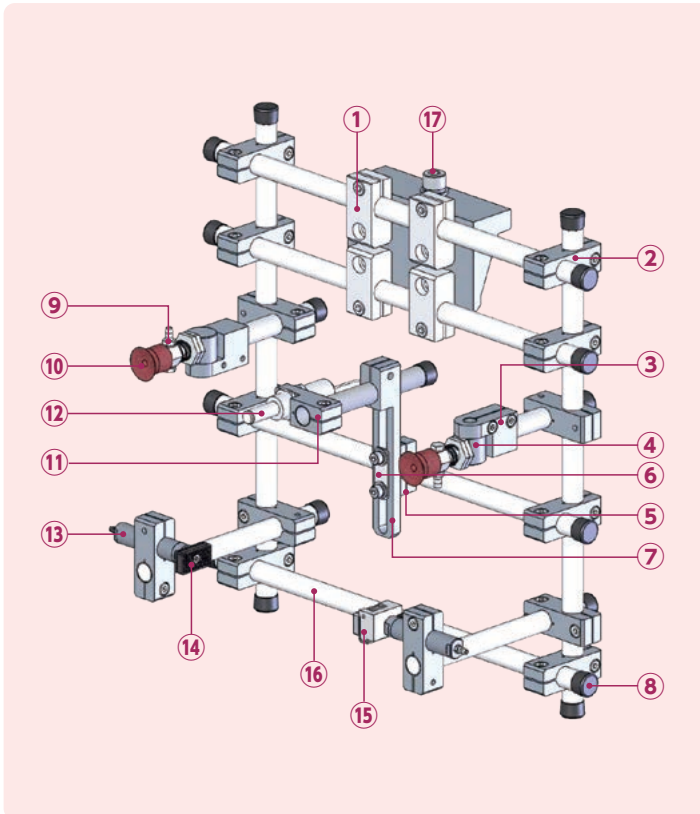

Configuration parts	TYPE	Order code No.	No. of uses
① : Attachment bracket · $\phi 12 \cdot M6$	N01862-201	131118	4
② : Cross connector · $\phi 12 \phi 12$	N01861-202	131099	14
③ : Rotation bracket · $\phi 12 \cdot 8B$	N01864-101A	131600	2
④ : Rotation bracket · $\phi 8 \cdot M12A$	N01864-205-2	131433	2
⑤ : Slide bracket · W · $\phi 12$	N01863-101	131128	1
⑥ : Slide washer · W · $\phi 8 / \phi 12$	N01863-102	131129	1
⑦ : Slide bracket 70 · W · $\phi 12$	N01863-103	131130	1
⑧ : Pipe end cap (black) · $\phi 12$	R-CAP-12	171339	17
⑨ : Suction stem for small	VFIL-S-5A	210974	2
⑩ : Suction cups	VAPH-20C	210194	2
⑪ : Connector · for SSW	N01861-108	131097	1
⑫ : Star sensor	SSW-15	181139	1
⑬ : Cylinder for pipe attachment	MCP1-1210	123699	2
⑭ : Pad rectangle black for micro mini cylinder	CPUM-01	022797	1
⑮ : Pad rectangle SW for micro mini cylinder	L1131-100	110568	1
⑯ : Jungle gym SUS pipe $\phi 12$	12 * 0.5 * 500	271527	7
⑰ : Quick Chuck Change · Manual · tool side	OA1-SAI	140257	1

Quick Chuck Change

Quick Chuck Change Manual

Quick Chuck Change Manual (OM Type)

Tool Changer

Automated Hand Exchange System

Grip

Mini Cylinder

Accessories for Mini Cylinder

Container Cylinders

Accessories for Container Cylinder

Grippers

Rubber Material / Grip Pad

Suction

Suction Cups

Suction Stems

Pad in Pad

Vacuum Gripper

Air Ejector / Filter / Check Valve

Ultra Small Part Take Out

Vacuum Generator Unit

Cut

Air Nipper (Small-Medium)

Air Nipper (Large)

Frame / Module

Jungle Gym

Let's Joint

Rectangular Tube

Base Aluminum Material

Sliding Chuck

Pneumatic Components / Sensors

Pneumatic Components

Sensors / Multi AND Board

PCIO Communication Unit

Lightweight Parts Series

Frame / Suction / Resin Cylinders / Pads / Resin Manifolds

By Industry

Logistics-Palletizing/Sheet Metal-Stamping-Metal Fabrication

Assembling Tools

Tool / Jig

Information

Various Products Information

Examples of Robot Chuck Production

Examples of Chuck products ③

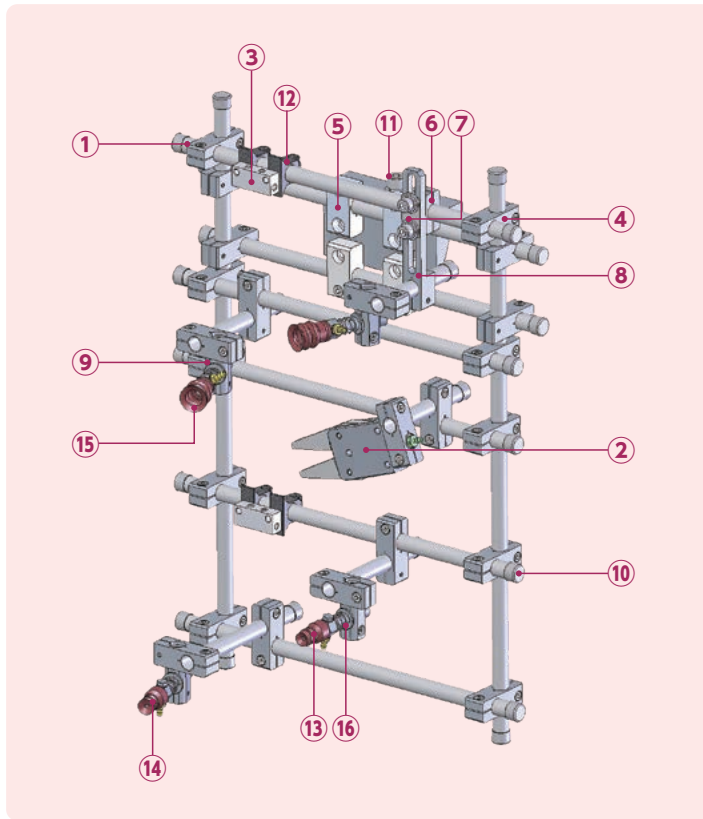

Configuration parts	TYPE	Order code No.	No. of uses
① Jungle gym SUS pipe ϕ 12	12 * 0.6 * 500	271527	12
② Runner chuck EL (w/o sensor)	CHK-EL1-12	022994	1
③ Manifold	MM-6P	122034	2
④ ϕ 12 ϕ 12 Cross connector	N01861-202	131099	23
⑤ Attachment bracket $\cdot \phi$ 12 \cdot M6	N01862-201	131118	4
⑥ Attachment bracket \cdot W $\cdot \phi$ 12	N01863-101	131128	1
⑦ Slide bracket \cdot W $\cdot \phi$ 8/ ϕ 12	N01863-102	131129	1
⑧ Slide bracket 70 \cdot W $\cdot \phi$ 12	N01863-103	131130	1
⑨ Rotation bracket $\cdot \phi$ 12 \cdot 12A	N01864-301	131168	4
⑩ Pipe end cap (black) $\cdot \phi$ 12	R-CAP-12	171339	23
⑪ Quick Chuck Change \cdot Manual \cdot tool side	OA1-SAI	140257	1
⑫ Plastic Fixture (M4)	RCB12	171212	4
⑬ Suction cups	TR-1062-3	196135	1
⑭ Suction cups	TR-1062-4	196136	1
⑮ Bellows cup	VAPH-20C-3	210661	2
⑯ Suction stem for small	VFIL1-S-10-P12	211008	4

Examples of Chuck products ④

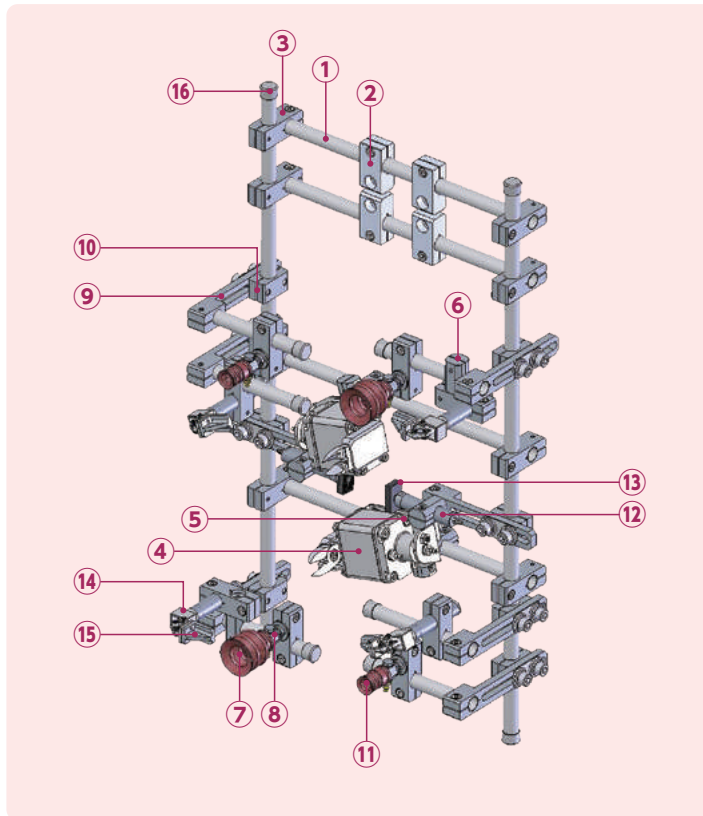

Configuration parts	TYPE	Order code No.	No. of uses
① Jungle gym SUS pipe ϕ 12	12 * 0.6 * 500	271527	7
② Attachment bracket $\cdot \phi$ 12 \cdot M6	N01862-201	131118	4
③ Cross connector $\cdot \phi$ 12 ϕ 12	N01861-202	131099	16
④ Mini air nipper \cdot Body \cdot Reverse blade	NW3-35	131643	2
⑤ Bracket \cdot W $\cdot \phi$ 12	N01915-106	131068	2
⑥ Rotation bracket $\cdot \phi$ 12 \cdot 12A	N01864-301	131168	8
⑦ Bellows cup	VAPH-30C-3	210662	2
⑧ Suction stem for small	VFIL1-S-5-P12	211006	4
⑨ Slide bracket 70 \cdot W $\cdot \phi$ 12	N01863-103	131130	8
⑩ Slide bracket \cdot W $\cdot \phi$ 12	N01863-101	131128	8
⑪ Bellows cup	VAPH-15C-3	210697	2
⑫ Cylinder for pipe attachment	MCP1-1220	123700	2
⑬ Pad rectangle for micro mini cylinder	CPUM-01	022797	2
⑭ Pipe combination chuck E ϕ 12 \cdot 90°	J25410-40A	090204	4
⑮ 90 degree flat A	N01871-101	131218	4
⑯ Pipe end cap $\cdot \phi$ 12	N01902-002	131211	10

Examples of Chuck products ⑤

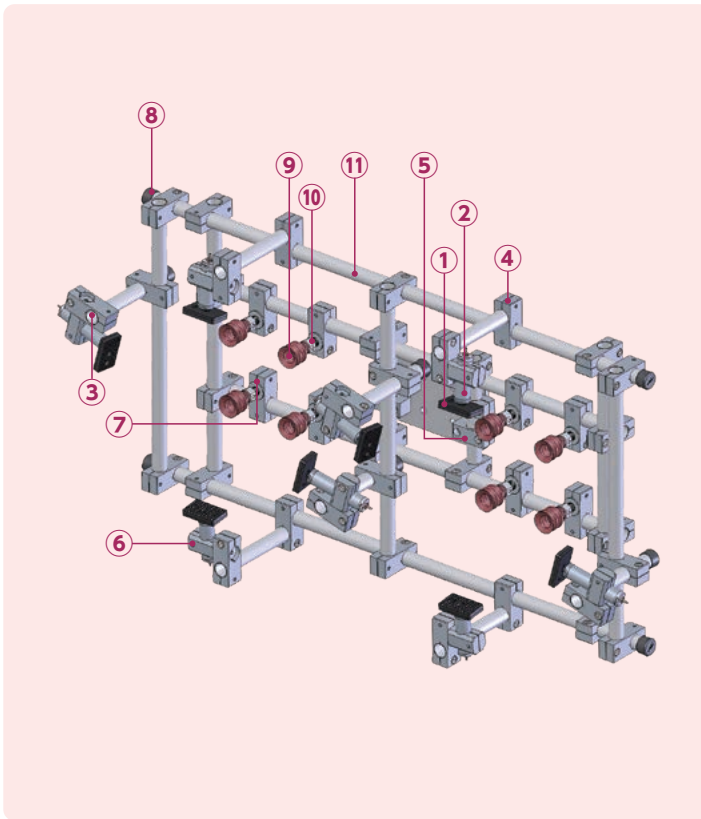

Configuration parts	TYPE	Order code No.	No. of uses
① Pad rectangle black 2 holes for mini cylinder	CPL-060	023336	8
② Cylinder for pipe attachment	MCP1-2010	123701	4
③ Cylinder for pipe attachment	MCP1-2030	123703	4
④ Cross connector · $\phi 20 \phi 20$	N01861-206	131101	42
⑤ Attachment bracket · $\phi 20 \cdot M6$	N01862-207	131123	4
⑥ Rotation bracket · $\phi 20 \cdot 20A$	N01864-304	131171	8
⑦ $\phi 20$ Bushing nut M12	N01868-409	131205	8
⑧ Pipe end cap (black) · $\phi 20$	R-CAP-20	171340	8
⑨ Bellows cup	VAPH-30C-3	210662	8
⑩ Suction stem · fixed	VFILK-S-M12	210698	8
⑪ Jungle gym SUS pipe	20*0.8*1000	281813	8

Examples of Chuck products ⑥

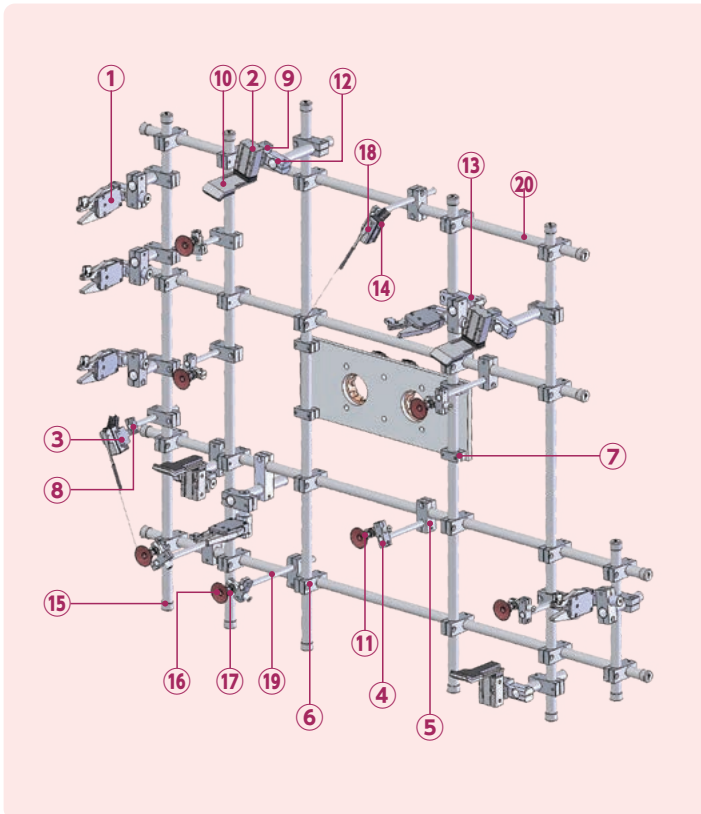

Configuration parts	TYPE	Order code No.	No. of uses
① Runner chuck EX (with Limit SW)	CHK-EX1-20-C1	023007	6
② Mini Container Cylinder	NCON-M20W	130711	4
③ Sensor bracket	N01915-201	131077	2
④ Cross connector · $\phi 12 \phi 12$	N01861-202	131099	7
⑤ Cross connector · $\phi 20 \phi 12$	N01861-204	131100	9
⑥ Cross connector · $\phi 20 \phi 20$	N01861-206	131101	36
⑦ Slide bracket · W · $\phi 20$	N01863-111	131134	4
⑧ Slide bracket · $\phi 12$	N01863-201	131145	2
⑨ bracket · T · $\phi 20$ · for MCD	N01866-303	131183	4
⑩ Pad · for mini container cylinder	NCON-CP-05	131260	4
⑪ Rotation bracket · $\phi 12 \cdot 12AL$	N01864-301L	131567	7
⑫ Rotation bracket · $\phi 20 \cdot 20AL$	N01864-304L	131568	10
⑬ Cross connector long · $\phi 20 \cdot \phi 20$	N01861-206B	131573	2
⑭ Limit switch micro case	OM-1	140039	2
⑮ Pipe end cap · $\phi 20$	R-CAP-20	171340	20
⑯ Suction Cups (Standard)	VAPH-40C	210196	7
⑰ Suction stem for small	VFIL1-S-5-P12	211006	7
⑱ Limit switch hinge lever	Z-15GW55-B	250017	2
⑲ Jungle gym SUS pipe $\phi 12$	12*0.6*1500	271529	1
⑳ Jungle gym SUS pipe $\phi 20$	20*0.8*1000	281813	4

Quick Chuck Change

Quick Chuck Change Manual

Quick Chuck Change Manual (OM Type)

Tool Changer

Automated Hand Exchange System

Grip

Mini Cylinder

Accessories for Mini Cylinder

Container Cylinders

Accessories for Container Cylinder

Grippers

Rubber Material / Grip Pad

Suction

Suction Cups

Suction Stems

Pad in Pad

Vacuum Gripper

Air Ejector / Filter / Check Valve

Ultra Small Part Take Out

Vacuum Generator Unit

Cut

Air Nipper (Small-Medium)

Air Nipper (Large)

Frame / Module

Jungle Gym

Let's Joint

Rectangular Tube

Base Aluminum Material

Sliding Chuck

Pneumatic Components / Sensors

Pneumatic Components

Sensors / Multi AND Board

PCIO Communication Unit

Lightweight Parts Series

Frame / Section / Resin Cylinders / Pads / Resin Manifolds

By Industry

Logistics - Palletizing / Sheet Metal - Stamping - Metal Fabrication

Assembling Tools

Tool / Jig

Information

Various Products Information

Use Cases of Parts

Suction Cups Mounting Example

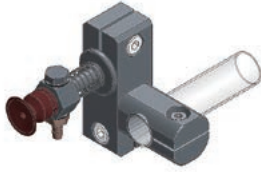

Configuration parts	TYPE	Order code No.
Suction stem mini	VFIL2-SS-10-P12	211034
Suction cups (standard/silicon/brown)	VAPH-14C	210616
Cross connector · φ 12 φ 12	N01861-202	131099
Rotation bracket · φ 12 · 12A	N01864-301	131168

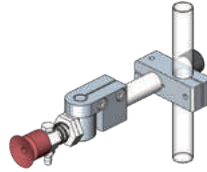

Configuration parts	TYPE	Order code No.
Cross connector · φ 12 φ 12	N01861-202	131099
Rotation bracket · φ 12 · 8B	N01864-101A	131600
Rotation bracket · φ 8 · M12A	N01864-205	131433
Suction stem for small (M5)	VFIL-S-5A	210974
Suction cups (standard/silicon/brown)	VAPH-20C	210194
Pipe end cap (black) · φ 12	R-CAP-12	171339
Jungle gym SUS pipe φ 12 *	12*0.6*500	271527

* Please cut it at 80mm before use.

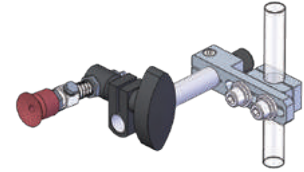

Configuration parts	TYPE	Order code No.
Slide bracket · W · φ 12	N01863-101	131128
Slide bracket 40 · W · φ 12	N01863-107	131132
Pipe end cap (black) · φ 12	R-CAP-12	171339
Slide washer · W · φ 8 / φ 12	N01863-102	131129
Suction Stem Non-Rotate for small	VFILB2-SH	211045
Suction cups (standard/silicon/brown)	VAPH-20C	210194
Clip · TMA · φ 12 * φ 10	TMA-CL (12*10)	196564
Jungle gym SUS pipe φ 12 *	12*0.6*500	271527

* Please cut it at 100mm before use.

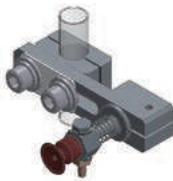

Configuration parts	TYPE	Order code No.
Suction stem mini	VFIL2-SS-10-P12	211034
Suction cups (standard/silicon/brown)	VAPH-14C	210616
Slide bracket · W · φ 12	N01863-101	131128
Slide bracket 40 · W · φ 12	N01863-107	131132
Slide washer · W · φ 8 φ 12	N01863-102	131129

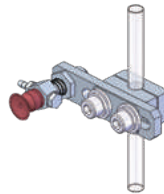

Configuration parts	TYPE	Order code No.
Slide bracket · W · φ 8	N01863-113	131217
Slide washer · W · φ 8 / φ 12	N01863-102	131129
Slide bracket 40 · W · M10	N01863-117	131139
Suction stem for mini	VFIL1-SS-5	211029
Suction cups (standard/silicon/brown)	VAPH-14C	210616

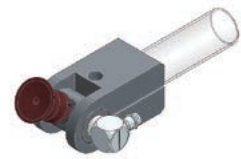

Configuration parts	TYPE	Order code No.
Suction cups (standard/silicon/brown)	VAPH-14C	210616
Suction stem attachment head for mini	N01392-201	131208
Suction rotate # B · M5 · φ 12	N01868-102	131192
Suction rotate # A · φ 12	N01868-101	131191

Air Cylinder Mounting Example



Configuration parts	TYPE	Order code No.
Pad rectangle black 2 holes for mini cylinder	CPL-060	023336
Mini cylinder · for MCD	MCD1-10	123219
Bracket · T · φ 12 · for MCD	N01866-101	131176



Configuration parts	TYPE	Order code No.
Pad rectangle black SW for mini cylinder	KRCR-5000	101832
Mini cylinder · for MCD	MCD1-10	123219
Bracket · TH · φ 12 · for MCD	N01866-301	131181

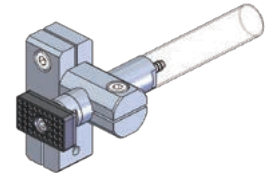

Configuration parts	TYPE	Order code No.
Cylinder for pipe attachment	MCP1-1210	123699
Pad rectangle black for micro mini cylinder	CPUM-01	022797
Cross connector · φ 12 φ 12	N01861-202	131099
Rotation bracket · φ 12 · 12A	N01864-301	131168
Bolt with hexagon socket (trivalent chrome white)	M3*6	123231

Air Nipper Mounting Example

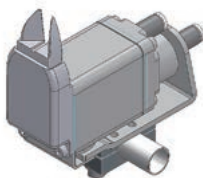

Configuration parts	TYPE	Order code No.
Bracket · W · φ 12	N01915-106	131068
Mini air nipper · Body · Standard blade	NW3-20	131629

Sensor Mounting Example

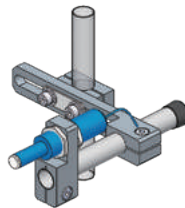

Configuration parts	TYPE	Order code No.
Slide bracket · W · φ 12	N01863-101	131128
Slide washer · W · φ 8 / φ 12	N01863-102	131129
Slide bracket 70 · W · φ 12	N01863-103	131130
Connector · for SSW	N01861-108	131097
Star sensor	SSW-15	181139
Pipe end cap (black) · φ 12	R-CAP-12	171339
Jungle gym SUS pipe φ 12 *	12*0.6*500	271527

* Please cut it at 100mm before use.

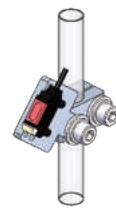

Configuration parts	TYPE	Order code No.
Slide bracket · W · φ 12	N01863-101	131128
Sensor bracket	N01915-201	131077
Photo sensor	E3T-SL21R (NPN)	041412

MEMO

A series of horizontal dashed lines for writing.



Let's Joint

- ▶ Combination of various parts makes it easy to create the robot hand suitable for the shapes of work piece.
- ▶ Light weight and easy fabrication.

Frame / Module

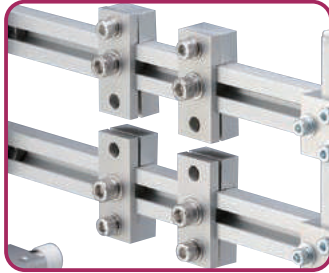

Grip

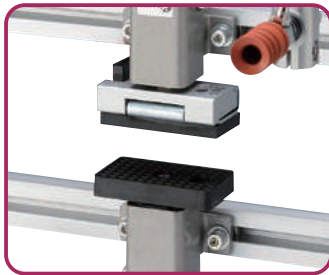

Suction

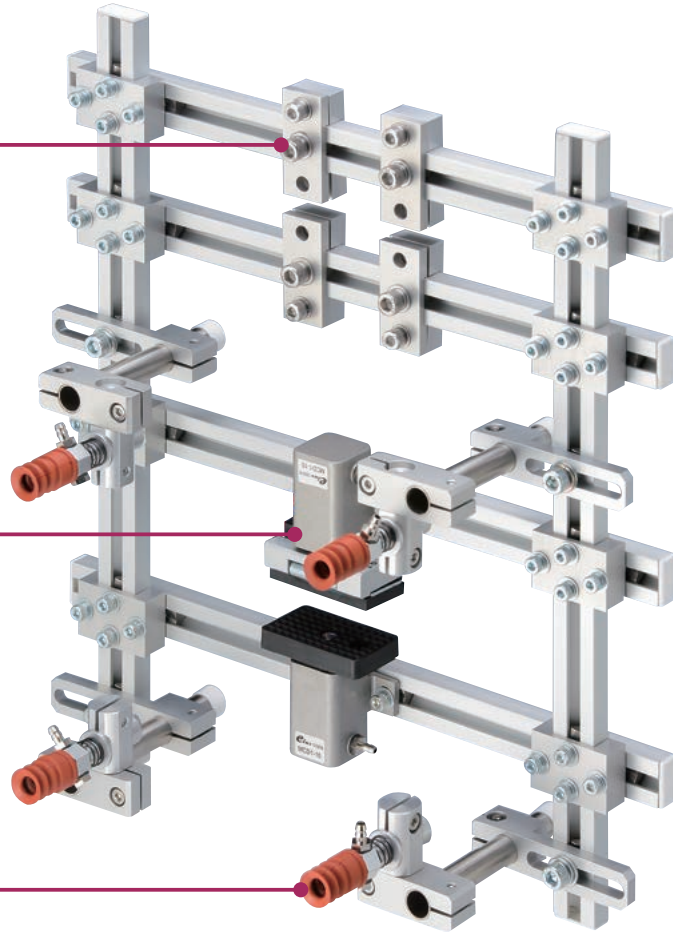
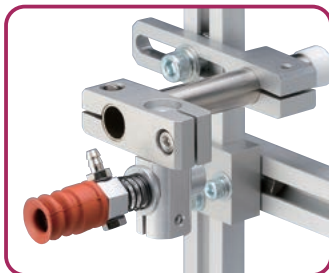

Tubing **6-1**

Let's Joint series parts based on three different size of aluminum profile extrusions to build the robot hand.
Determine extract method first. And choose your favorite parts from the product list

Example of using other components parts

- ▶ Let's Joint + Connector + Bracket + Nut

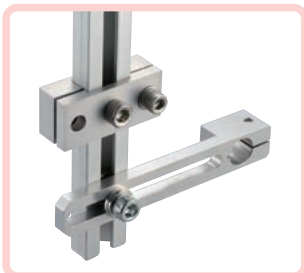

Order code No.	271520
TYPE	10*20*500

Order code No.	131130
TYPE	N01863-103

Order code No.	131222
TYPE	N01911-204-205SET

Order code No.	131056
TYPE	N01914-103



List of Let's Joint

Various parts can be attached to let's joint frame.



You can see moving images of products by using QR code reader of your smartphone

You can check more details such as drawing by eins online shop.

Specification

Product name	Order code No.	TYPE
Frame Let's joint profile		271520 10*20*500
		271521 10*20*1000
		271515 10*20*1500
		281807 25*25*500
		281809 25*25*1000
		281753 25*25*1500
		281808 25*50*500
		281810 25*50*1000
		281754 25*50*1500
		131213 25*50*1500
		131214 25*50*1500
		131215 25*50*1500
		131221 N01911-201-203SET
		131222 N01911-204-205SET
		131223 N01911-208-106-201SET
131224 N01911-101-102SET		
131028 N01911-206		
131019 N01911-103		
131033 N01911-401		

Product name	Order code No.	TYPE	
Connector	Cross connector • 50	131032 N01911-301	
	Connector 20 • F	131029 N01911-207	
	Connector 20 • G	131031 N01911-209	
	Cylinder connector 25 • A	131020 N01911-104	
	Cylinder connector 25 • B	131021 N01911-105	
	Block	Connector block 50 • B	131040 N01912-203
Connector block • for GCYL		131039 N01912-202	
Connector block • light		131038 N01912-106	
Connector block 25/50 • A		131041 N01912-301	
Connector block 25 • C		131035 N01912-103	
Connector block 25 • D		131036 N01912-104	
Bracket		Slide bracket 40 • M3	131158 N01863-214
		Slide bracket 40 • M5	131147 N01863-203
		Slide bracket 40 • M6	131156 N01863-212
		Slide bracket 40 • PT1/8	131154 N01863-210
	Slide bracket 40 • W • M10	131139 N01863-117	
	Slide bracket 40 • W • M12	131140 N01863-118	
	Slide bracket 40 • W • M17	131143 N01863-122	
	Slide bracket 40 • φ8	131152 N01863-208	

Quick Chuck Change

Quick Chuck Change Manual

Quick Chuck Change Manual (OM Type)

Tool Changer

Automated Hand Exchange System

Grip

Mini Cylinder

Accessories for Mini Cylinder

Container Cylinders

Accessories for Container Cylinder

Grippers

Rubber Material / Grip Pad

Suction

Suction Cups

Suction Stems

Pad in Pad

Vacuum Gripper

Air Ejector / Filter / Check Valve

Ultra Small Part Take Out

Vacuum Generator Unit

Cut

Air Nipper (Small-Medium)

Air Nipper (Large)

Frame / Module

Jungle Gym

Let's Joint

Rectangular Tube

Base Aluminum Material

Sliding Chuck

Pneumatic Components / Sensors

Pneumatic Components

Sensors / Multi AND Board

PCIO Communication Unit

Lightweight Parts Series

Frame / Suction / Resin Cylinders / Pads / Resin Manifolds

By Industry

Logistics-Palletizing/Sheet Metal-Stamping-Metal Fabrication

Assembling Tools

Tool / Jig

Information

Various Products Information

List of Let's Joint



















You can check more details such as drawing by eins online shop.

Product name	Order code No. TYPE
Slide bracket 40 · W · ϕ 8	131131 N01863-106
Slide bracket 40 · W · ϕ 12	131132 N01863-107
Slide bracket 40 · W · ϕ 20	131137 N01863-114
Slide bracket 40 · T · W · ϕ 8	230051 XL0005-102
Slide bracket 40 · T · ϕ 8	230056 XL0005-107
Slide bracket 40 · T · ϕ 12	230052 XL0005-103
Slide bracket 40 · T · ϕ 20	230054 XL0005-105
Slide bracket 70 · M3	131159 N01863-217
Slide bracket 70 · M5	131148 N01863-204
Slide bracket 70 · M6	131157 N01863-213
Slide bracket 70 · PT1/8	131155 N01863-211
Slide bracket 70 · W · M10	131141 N01863-120
Slide bracket 70 · W · M12	131142 N01863-121
Slide bracket 70 · W · M17	131144 N01863-124
Slide bracket 70 · ϕ 8	131153 N01863-209
Slide bracket 70 · W · ϕ 8	131133 N01863-110
Slide bracket 70 · W · ϕ 12	131130 N01863-103
Slide bracket 70 · W · ϕ 20	131138 N01863-115
Slide bracket 70 · T · W · ϕ 8	230053 XL0005-104

Product name	Order code No. TYPE
Slide bracket 70 · T · ϕ 8	230057 XL0005-108
Slide bracket 70 · T · ϕ 12	230050 XL0005-101
Slide bracket 70 · T · ϕ 20	230055 XL0005-106
Swing Bracket	131065 N01915-102
Connector bracket 25 · E	131037 N01912-105
Suction link bracket · M12	131090 N01918-201
Cylinder bracket · ϕ 8	131075 N01915-113
Cylinder bracket · ϕ 12	131074 N01915-112
Cylinder bracket · ϕ 20	131066 N01915-103
Link bracket 25/50	131034 N01911-402
Chuck bracket · ϕ 12	131067 N01915-105
Sensor bracket	131077 N01915-201
Nipper bracket · D	131081 N01915-304
Nipper bracket · E	131082 N01915-305
Bracket · NCON	131083 N01915-401
Bracket · ϕ 8	131073 N01915-111
Bracket · ϕ 12	131071 N01915-109
Bracket · ϕ 20	131072 N01915-110
Bracket · W · ϕ 8	131070 N01915-108



You can see moving images of products by using QR code reader of your smartphone

Product name		Order code No.		
		TYPE		
Bracket	Bracket • W • ϕ 12		131068 N01915-106	
	Bracket • W • ϕ 20		131069 N01915-107	
	Rotation bracket • ϕ 20		131064 N01915-101	
Plate	Connect plate 20 • A		131413 N01913-201	
	Connect plate 25 • A		131406 N01913-101	
	Connect plate 25 • B		131407 N01913-102	
	Connect plate 25 • C		131405 N01913-103	
	Connect plate 25 • D		131408 N01913-104	
	Connect plate 25 • F		131410 N01913-106	
	Connect plate 25 • G		131411 N01913-107	
	Connect plate 25 • H		131412 N01913-108	
	Connect plate 25/50 • A		131416 N01913-401	
	Connect plate 50 • A		131414 N01913-301	
	Connect plate 50 • B		131415 N01913-302	
	Washer	Washer A • for let's joint		131087 N01918-102
		Washer B • for let's joint		131088 N01918-103
Nut	Nut • M4		131061 N01914-108	
	Nut • M4 • 2P • 32, M5 • 2P • 28		131063 N01914-202	
	Nut • M4 • 2P • 38, M3 • 2P • 20		131062 N01914-201	

Product name		Order code No.	
		TYPE	
Nut	Nut • M6		131056 N01914-103
	Nut • M6 • 2P • 12		131055 N01914-102
	Nut • M6 • 2P • 15		131054 N01914-101
	Nut • M6 • 2P • 20		131058 N01914-105
	Nut • M6 • 2P • 25		131059 N01914-106
	Nut • M6 • 3P • 15		131057 N01914-104
Guide bar	Guide bar • 100		131084 N01916-201
	Guide bar • 200		131085 N01916-202
Spacer	Spacer 25 • T5 • P25		131086 N01918-101
Plate	Attach plate • A		131091 N01918-301

Quick Chuck Change

Quick Chuck Change Manual

Quick Chuck Change Manual (OM Type)

Tool Changer

Automated Hand Exchange System

Grip

Mini Cylinder

Accessories for Mini Cylinder

Container Cylinders

Accessories for Container Cylinder

Grippers

Rubber Material / Grip Pad

Suction

Suction Cups

Suction Stems

Pad in Pad

Vacuum Gripper

Air Ejector / Filter / Check Valve

Ultra Small Part Take Out

Vacuum Generator Unit

Cut

Air Nipper (Small-Medium)

Air Nipper (Large)

Frame / Module

Jungle Gym

Let's Joint

Rectangular Tube

Base Aluminum Material

Sliding Chuck

Pneumatic Components / Sensors

Pneumatic Components

Sensors / Multi AND Board

PCIO Communication Unit

Lightweight Parts Series

Frame / Section / Resin Cylinders / Pads / Resin Manifolds

By Industry

Logistics-Palletizing / Sheet Metal-Stamping- Metal Fabrication

Assembling Tools

Tool / Jig

Information

Various Products Information



Base Frame Module

Modularized hand parts for let's joint.

You can check more details such as drawing by eins online shop.

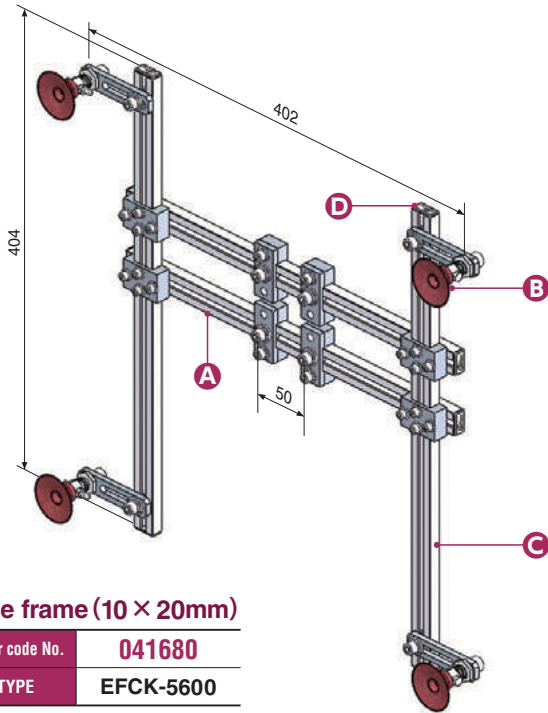

Base frame (10 × 20mm)

Order code No.	041680
TYPE	EFCK-5600

● Weight : 775g

Configuration module	TYPE	Order code No.	No. of uses	Details
A Base frame for let's joint.	EFCK-5601	041681	2	5-38
B Suction module for let's joint.	LSM-003	110571	4	5-39
C Let's joint profile	10*20*500	271520	2	5-35
D Profile end cap · 10-20	N01902-004	131213	4	5-35

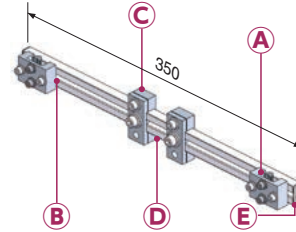

components of EFCK-5600...**A**

Order code No.	041681
TYPE	EFCK-5601

● Weight : 180g

Configuration parts	TYPE	Order code No.	No. of uses	Details
A Connector 20 · F	N01911-207	131029	2	5-35
B Nut · M4	N01914-108	131061	8	5-37
C Connector 20 · set C	N01911-204-205set	131222	2	5-35
D Let's joint profile	10*20*500	271520	1	5-35
E Profile end cap · 10-20	N01902-004	131213	2	5-35

Base frame for let's joint.

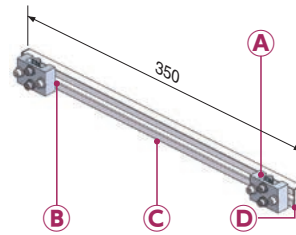

Order code No.	041682
TYPE	EFCK-5602

● Weight : 130g

Configuration parts	TYPE	Order code No.	No. of uses	Details
A Connector 20 · F	N01911-207	131029	2	5-35
B Nut · M4	N01914-108	131061	8	5-37
C Let's joint profile	10*20*500	271520	1	5-35
D Profile end cap · 10-20	N01902-004	131213	2	5-35

Frame / Module ● Let's Joint

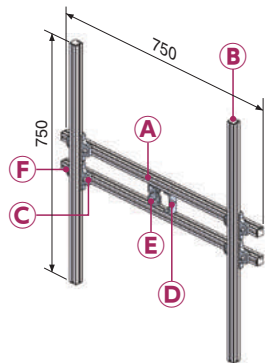

Base frame (25 × 25mm)

Order code No.	041683
TYPE	EFCK-7000

● Weight : 3,114g

Configuration parts	TYPE	Order code No.	No. of uses	Details
A Let's joint · 25 * 25 * 1500	25 * 25 * 1500	281753	2	5-35
B Profile end cap · 25 · 25	N01902-005	131214	8	5-35
C Cross connector · 25	N01911-103	131019	4	5-35
D Connector block 25 · C	N01912-103	131035	4	5-35
E Nut · M6 · 2P · 15	N01914-101	131054	4	5-37
F Nut · M6	N01914-103	131056	16	5-37

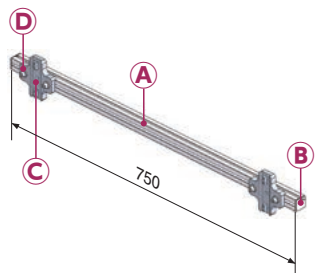

Base frame for let's joint.

Order code No.	041685
TYPE	EFCK-7002

● Weight : 961g

Configuration parts	TYPE	Order code No.	No. of uses	Details
A Let's joint · 25 * 25 * 1000	25 * 25 * 1000	281809	1	5-35
B Profile end cap · 25 · 25	N01902-005	131214	2	5-35
C Cross connector · 25	N01911-103	131019	2	5-35
D Nut · M6	N01914-103	131056	8	5-37

Switch to a single sale as the sales method.

► Change in sales method

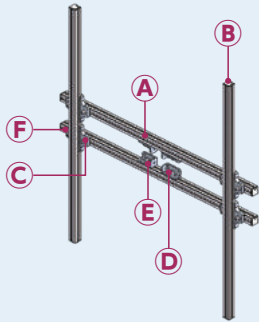

Base frame

Order code No.	041686
TYPE	EFCK-7500

● Weight : 3,476g

Configuration parts	TYPE	Order code No.	No. of uses	Details
A Let's joint · 25 * 25 * 1500	25 * 25 * 1500	281753	2	5-35
B Profile end cap · 25 · 25	N01902-005	131214	8	5-35
C Cross connector · 25	N01911-103	131019	4	5-35
D Connector block 25 · D	N01912-104	131036	4	5-35
E Nut · M6 · 2P · 15	N01914-101	131054	4	5-37
F Nut · M6	N01914-103	131056	16	5-37

* PROFILE length is 1,500mm if only PROFILE is ordered.

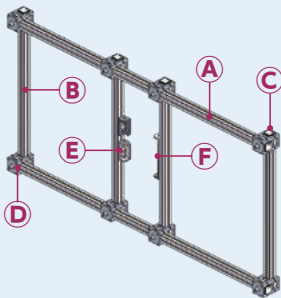

Base frame

Order code No.	041689
TYPE	EFCK-7600

● Weight : 3,992g

Configuration parts	TYPE	Order code No.	No. of uses	Details
A Let's joint · 25 * 25 * 1000	25 * 25 * 1000	281809	2	5-35
B Let's joint · 25 * 25 * 500	25 * 25 * 500	281807	4	5-35
C Profile end cap · 25 · 25	N01902-005	131214	12	5-35
D Connector 25 · set A	N01911-101-102SET	131224	8	5-35
E Connector block 25 · D	N01912-104	131036	4	5-35
F Nut · M6 · 2P · 15	N01914-101	131054	4	5-37

* PROFILE length is 1,000 and 500mm if only PROFILE is ordered.

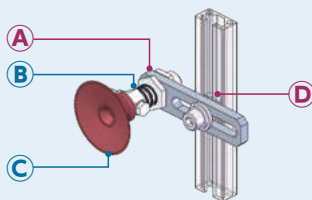

Suction module for let's joint

Order code No.	110571
TYPE	LSM-003

● Weight : 50g

Configuration parts	TYPE	Order code No.	No. of uses	Details
A Slide bracket 40 · W · M12	N01863-118	131140	1	5-35
B Suction stem for small	VFIL-S-5A	210974	1	3-26
C Suction cups (standard/silicon/brown)	VAPH-40C	210196	1	3-5
D Nut · M6	N01914-103	131056	1	5-37

* Components of EFCK-5600 ®



Base frame for let's joint.

Order code No.	041684
TYPE	EFCK-7001

● Weight : 1,030g

Configuration parts	TYPE	Order code No.	No. of uses	Details
A Cross connector · 25	N01911-103	131019	2	5-35
B Connector block 25 · D	N01912-104	131036	2	5-35
C Nut · M6 · 2P · 15	N01914-101	131054	2	5-37
D Profile end cap · 25 · 25	N01902-005	131214	2	5-35
E PROFILE25 * 25	25 * 25 * 500	281807	1	5-35

* PROFILE length is 500mm if only PROFILE is ordered.

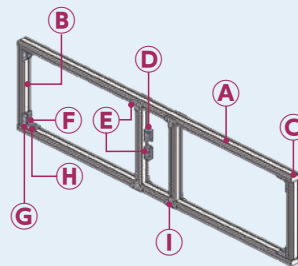

Base frame

Order code No.	041692
TYPE	EFCK-8000

● Weight : 7,612g

Configuration parts	TYPE	Order code No.	No. of uses	Details
A Let's joint · 25 * 50 * 1500	25 * 50 * 1500	281754	2	5-35
B Let's joint · 25 * 50 * 500	25 * 50 * 500	281808	4	5-35
C Profile end cap · 25 · 50	N01902-006	131215	4	5-35
D Connector block 25 · D	N01912-104	131036	4	5-35
E Nut · M6 · 2P · 15	N01914-101	131054	20	5-37
F Connector block 50 · B	N01912-203	131040	4	5-35
G Nut · M6 · 2P · 20	N01914-105	131058	8	5-37
H Nut · M6 · 2P · 25	N01914-106	131059	8	5-37
I Connector plate 25 · D	N01913-104	131408	8	5-37

* PROFILE length is 1,500 and 500mm if only PROFILE is ordered.

Quick Chuck Change

Quick Chuck Change Manual

Quick Chuck Change Manual (OM Type)

Tool Changer

Automated Hand Exchange System

Grip

Mini Cylinder

Accessories for Mini Cylinder

Container Cylinders

Accessories for Container Cylinder

Grippers

Rubber Material / Grip Pad

Suction

Suction Cups

Suction Stems

Pad in Pad

Vacuum Gripper

Air Ejector / Filter / Check Valve

Ultra Small Part Take Out

Vacuum Generator Unit

Cut

Air Nipper (Small-Medium)

Air Nipper (Large)

Frame / Module

Jungle Gym

Let's Joint

Rectangular Tube

Base Aluminum Material

Sliding Chuck

Pneumatic Components / Sensors

Pneumatic Components

Sensors / Multi AND Board

PCIO Communication Unit

Lightweight Parts Series

Frame / Suction / Resin Cylinders / Pads / Resin Manifolds

By Industry

Logistics - Palletizing / Sheet Metal - Stamping - Metal Fabrication

Assembling Tools

Tool / Jig

Information

Various Products Information



Examples of Robot Chuck Production

Chuck parts based on Let's joint parts.

Examples of Chuck products ①

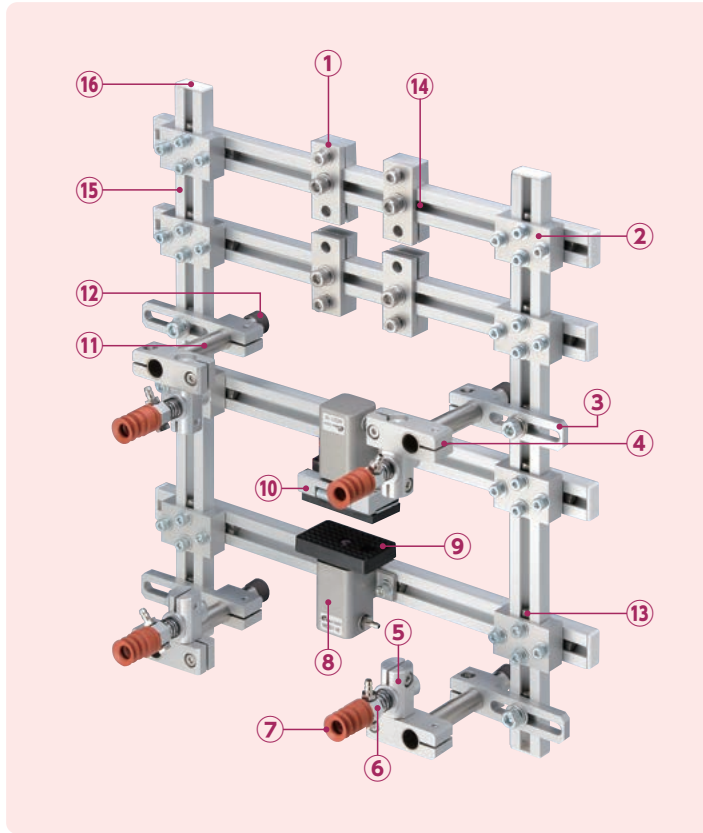

Configuration parts	TYPE	Order code No.	No. of uses
① Connector 20 · set C	N01911-201-203SET	131222	4
② Connector 20F	N01911-207	131029	8
③ Slide 40BKT · W · ϕ 12	N01863-107	131132	4
④ Cross connector · ϕ 12 ϕ 12	N01861-202	131099	4
⑤ Rotation bracket · ϕ 12 · 12A	N01864-301	131600	4
⑥ Suction stem for small	VFIL1-S-5-P12	211006	4
⑦ Suction cups	VAPH-20C-3	210661	4
⑧ Mini cylinder · MCD	MCD1-10	123219	2
⑨ Pad rectangle black 2 holes for mini cylinder	CPL-060	023336	1
⑩ Pad rectangle w/ SW for mini cylinder	KRCR-5000	101832	1
⑪ SUS pipe ϕ 12	12*0.5*500	271527	1
⑫ Pipe end cap (Black) · ϕ 12	R-CAP-12	171339	4
⑬ Nut · M4	N01914-108	131061	36
⑭ Nut · M6	N01914-103	131056	4
⑮ Frame (Let's joint)	10*20*1000	271515	3
⑯ Profile end cap · 10-20	N01902-004	131213	12

Examples of Chuck Production ②

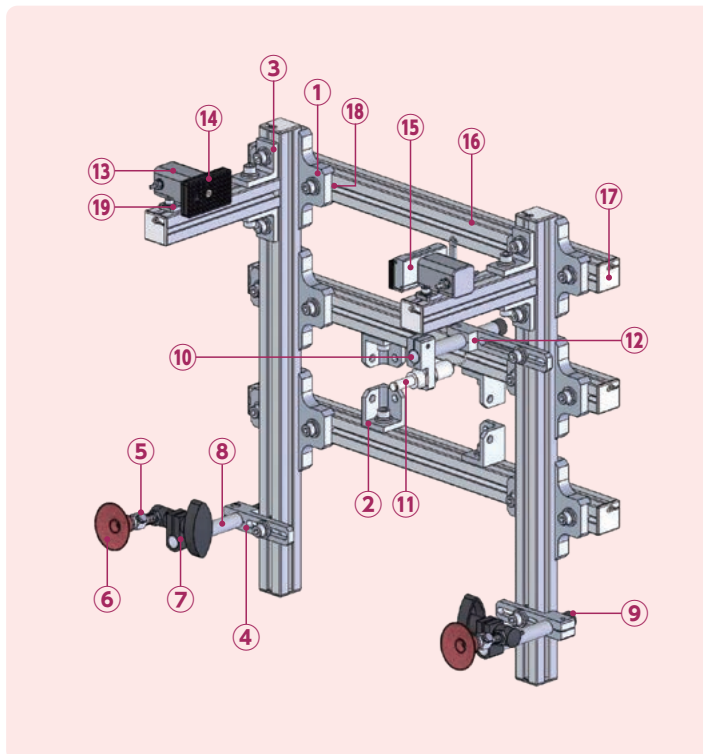

Configuration parts	TYPE	Order code No.	No. of uses
① Cross connector · 20	N01911-103	131019	6
② Connector block · 25 · D	N01912-104	131036	4
③ Connector block Light	N01912-106	131038	4
④ Slide 40BKT · W · ϕ 12	N01863-107	131132	2
⑤ Suction stem for small	VFIL1-S-5-P12	211006	2
⑥ Suction cups	VAPH-40C	210196	2
⑦ Clip · TMA · ϕ 12 * ϕ 12	TMA-CL (12*12)	196562	2
⑧ SUS pipe ϕ 12	12*0.5*500	271527	1
⑨ Pipe end cap (Black) · ϕ 12	R-CAP-12	171339	3
⑩ Connector · for SSW	N01861-108	131097	1
⑪ Star sensor	SSW-15	181139	1
⑫ Bracket · W · ϕ 12	N01915-106	131068	1
⑬ Mini cylinder · MCD	MCD1-10	123219	2
⑭ Pad rectangle black 2 holes for mini cylinder	CPL-060	023336	1
⑮ Pad rectangle w/ SW for mini cylinder	KRCR-5000	101832	1
⑯ Frame (Let's joint)	25 * 25 * 500	281807	6
⑰ Profile end cap · 25-25	N01902-005	131214	12
⑱ Nut · M6	N01914-103	131056	40
⑲ Nut · M4 2P32.M3 2P28	N01914-202	131063	2

Use Cases of Parts

Suction Cups Mounting Example

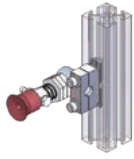

Configuration parts	TYPE	Order code No.
Bracket · φ8	N01915-111	131073
Rotation bracket · φ8 · M12A	N01864-205	131433
Suction stem for small	VFIL-S-5A	210974
Suction cups (standard/silicon/brown)	VAPH-20C	210194
Nut · M4	N01914-108	131061
Slide washer · φ8 / φ12	N01863-202	131146
Bolt with hexagon socket (trivalent chromate white) for M4 SW, flat W	M4 * 25	122798
	M4	122773, 122778

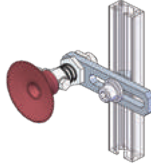

Configuration parts	TYPE	Order code No.
Slide bracket 40 · W · M12	N01863-118	131140
Suction stem for small	VFIL-S-5A	210974
Suction cups (standard/silicon/brown)	VAPH-40C	210196
Nut · M6	N01914-103	131056
Bolt with hexagon socket (SW + flat W) (trivalent chromate white)	M6 * 15 (E)	122821

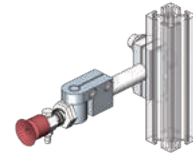

Configuration parts	TYPE	Order code No.
Nut · M6 · 3P · 15	N01914-104	131057
Chuck bracket · φ12	N01915-105	131067
Rotation bracket · φ12 · 8B	N01864-101A	131600
Rotation bracket · φ8 · M12A	N01864-205	131433
Suction stem for small	VFIL-S-5A	210974
Suction cups (standard/silicon/brown)	VAPH-20C	210194
Pipe end cap (black) · φ12	R-CAP-12	171339
Jungle gym SUS pipe φ12 *	12*0.6*500	271527
Bolt with hexagon socket (trivalent chromate white) for M6 SW, flat W	M6 * 25	122969
	M6	122775, 122780

* Please cut it at 80mm before use.

Air Cylinder Mounting Example

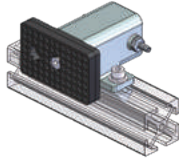

Configuration parts	TYPE	Order code No.
Mini cylinder · MCD1	MCD1-10	123219
Pad rectangle black 2 holes for mini cylinder	CPL-060	023336
Nut · M4 · 2P · 38, M3 · 2P · 20	N01914-201	131062
Fitting	BF-5	190109
Bolt with hexagon socket (SW + flat W) (trivalent chromate white)	M4 * 12 (E)	122812
Bolt with hexagon socket (trivalent chromate white)	M4 * 10	122795

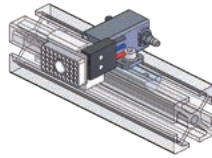

Configuration parts	TYPE	Order code No.
Micro mini cylinders	UMCD-10	200123
Pad rectangle w/ SW for micro mini cylinder	L1131-100	110568
Nut · M4 · 2P · 38, M3 · 2P · 20	N01914-201	131062
Fitting	BF-3	010473
Bolt with hexagon socket (trivalent chromate white) for M3 SW, flat W	M3 * 10	122790
	M3	122772, 122777
Bolt with hexagon socket (trivalent chromate white)	M3 * 8	123232

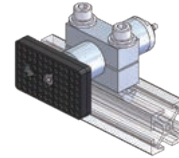

Configuration parts	TYPE	Order code No.
Cylinder for pipe attachment	MCP1-2010	123701
Pad rectangle black 2 holes for mini cylinder	CPL-060	023336
Bracket · W · φ20	N01915-107	131069
Nut · M6 · 3P · 15	N01914-104	131057
Bolt with hexagon socket (trivalent chromate white) for M6 SW, flat W	M6 * 35	122989
	M6	122775, 122780
Bolt with hexagon socket (trivalent chromate white)	M4 * 10	122795

Air Nipper Mounting Example

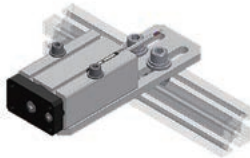

Configuration parts	TYPE	Order code No.
Pad · for mini container cylinder	NCON-CP-01	131256
Mini container cylinder	NCON-M15S	131015
Bracket · NCON	N01915-401	131083
Nut · M6 · 2P · 20	N01914-105	131058

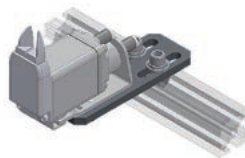

Configuration parts	TYPE	Order code No.
Mini air nipper · Body · Standard blade	NW3-20	131629
Nipper bracket · D	N01915-304	131081
Nut · M6 · 2P · 20	N01914-105	131058

Guide bar Mounting Example

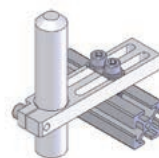

Configuration parts	TYPE	Order code No.
Guide bar · 100	N01916-201	131084
Cylinders bracket · φ20	N01915-103	131066
Nut · M6 · 2P · 20	N01914-105	131058
Washer B for let's joint	N01918-103	131088

Sensor Mounting Example

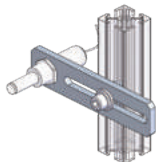

Configuration parts	TYPE	Order code No.
Slide bracket 70 · W · M17	N01863-124	131144
Star sensor	SSW-15	181139
Nut · M6	N01914-103	131056
Bolt with hexagon socket (SW + flat W) (trivalent chromate white)	M6 * 15 (E)	122821

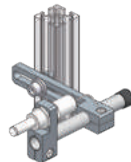

Configuration parts	TYPE	Order code No.
Slide bracket 70 · W · φ12	N01863-103	131130
Connector · for SSW	N01861-108	131097
Star sensor	SSW-15	181139
Pipe end cap (Black) · φ12	R-CAP-12	171339
Nut · M6	N01914-103	131056
Jungle gym SUS pipe φ12 *	12*0.6*500	271527
Bolt with hexagon socket (SW + flat W) (trivalent chromate white)	M6 * 15 (E)	122821

* Please cut it at 100mm before use.

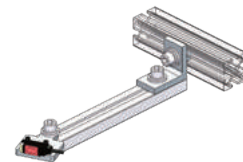

Configuration parts	TYPE	Order code No.
Connector block · light	N01912-106	131038
Sensor bracket	N01915-201	131077
Photo sensor	E3T-SL21R (NPN)	041412
Nut · M6	N01914-103	131056
Let's joint profile *	10*20*500	271520
Bolt with hexagon socket (SW + flat W) (trivalent chromate white)	M6 * 15 (E)	122821

* Please cut it at 150mm before use.

Quick Chuck Change

Quick Chuck Change Manual

Quick Chuck Change Manual (OM Type)

Tool Changer

Automated Hand Exchange System

Grip

Mini Cylinder

Accessories for Mini Cylinder

Container Cylinders

Accessories for Container Cylinder

Grippers

Rubber Material / Grip Pad

Suction

Suction Cups

Suction Stems

Pad in Pad

Vacuum Gripper

Air Ejector / Filter / Check Valve

Ultra Small Part Take Out

Vacuum Generator Unit

Cut

Air Nipper (Small-Medium)

Air Nipper (Large)

Frame / Module

Jungle Gym

Let's Joint

Rectangular Tube

Base Aluminum Material

Sliding Chuck

Pneumatic Components / Sensors

Pneumatic Components

Sensors / Multi AND Board

PCIO Communication Unit

Lightweight Parts Series

Frame / Section / Resin Cylinders / Pads / Resin Manifolds

By Industry

Logistics-Palletizing/Sheet Metal-Stamping-Metal Fabrication

Assembling Tools

Tool / Jig

Information

Various Products Information



Rectangular Tube

- ▶ Light weight, strong, and better rotate resistance.
- ▶ Combination of various parts makes it easy to create the robot hand suitable for the shapes of work piece.

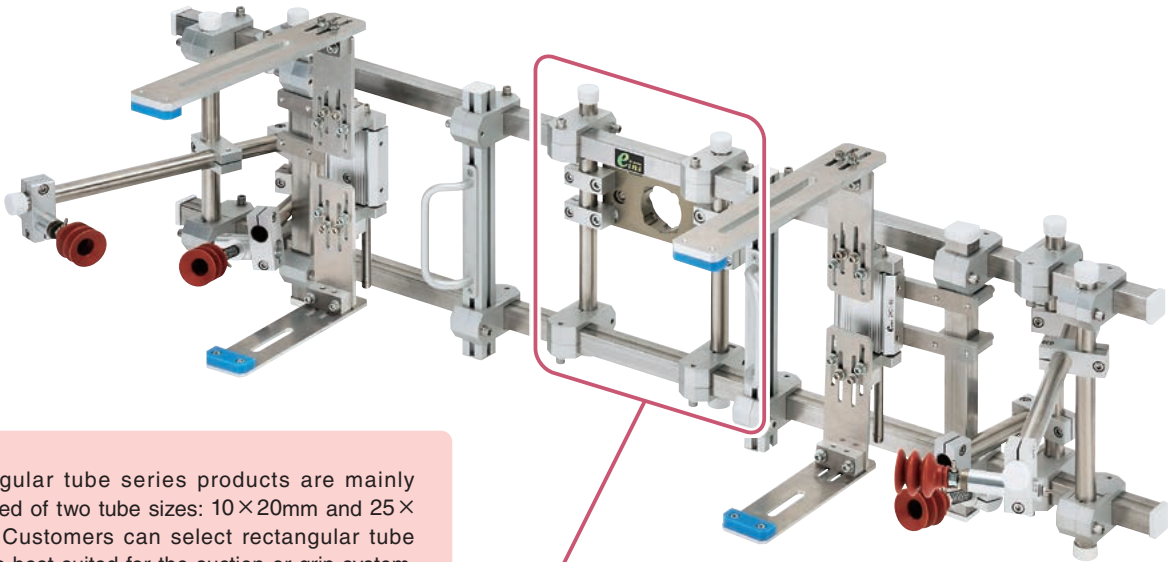

Rectangular tube series products are mainly composed of two tube sizes: 10×20mm and 25×25mm. Customers can select rectangular tube products best suited for the suction or grip system. Using the transformation block allows combinations of jungle gym parts.

Frame / Module • Rectangular Tube

**Attachment bracket •
φ20 • M8**



5-14

Tubing 6-1

Rectangular tube

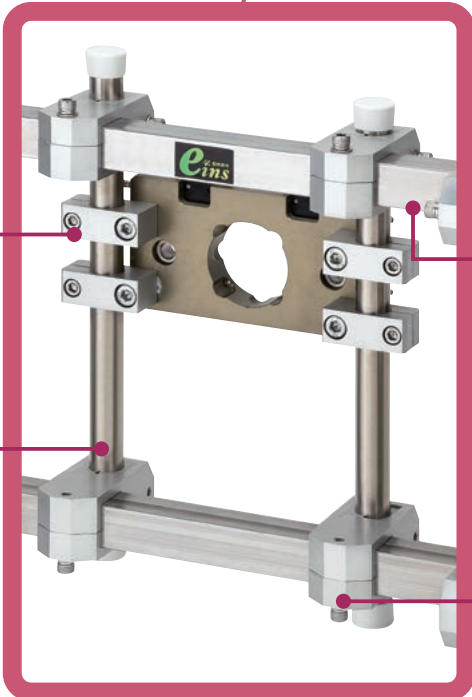

5-8

**Jungle gym
SUS pipe φ20**



5-45

**Cross connector •
25-25**

Conversion block • 25-φ20



Rectangular Tube / Pipe End Cap

Attaches various kinds of components based on the rectangular tube.



Rectangular tube

* Diameter of a pipe may expand when you cut the pipe.

Order code No.	185124
TYPE	S10*20*1500

● Weight : 535g

Order code No.	185125
TYPE	S25*25*1500

● Weight : 895g

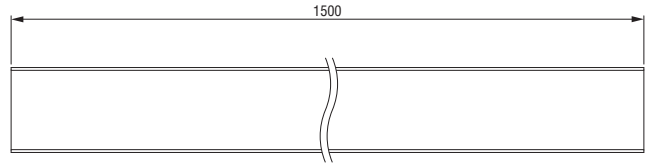
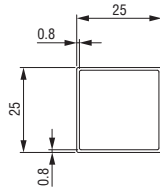
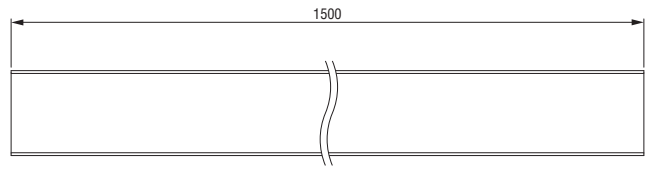
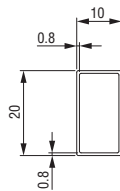

Pipe end cap • 10*20

Order code No.	185219
TYPE	S-CAP 10-20

● Weight : 1g

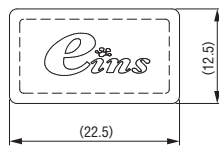
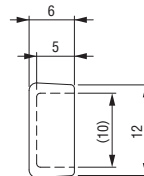
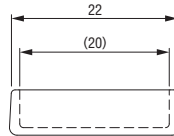

Pipe end cap • 25*25

Order code No.	185218
TYPE	S-CAP 25-25

● Weight : 3g

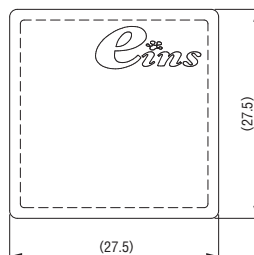
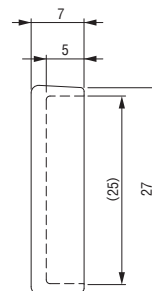
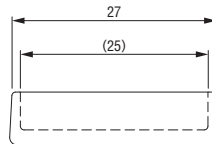

Quick Chuck Change

Quick Chuck Change Manual

Quick Chuck Change Manual (OM Type)

Tool Changer

Automated Hand Exchange System

Grip

Mini Cylinder

Accessories for Mini Cylinder

Container Cylinders

Accessories for Container Cylinder

Grippers

Rubber Material / Grip Pad

Suction

Suction Cups

Suction Stems

Pad in Pad

Vacuum Gripper

Air Ejector / Filter / Check Valve

Ultra Small Part Take Out

Vacuum Generator Unit

Cut

Air Nipper (Small-Medium)

Air Nipper (Large)

Frame / Module

Jungle Gym

Let's Joint

Rectangular Tube

Base Aluminum Material

Sliding Chuck

Pneumatic Components / Sensors

Pneumatic Components

Sensors / Multi AND Board

PCIO Communication Unit

Lightweight Parts Series

Frame / Section / Resin Cylinders / Pads / Resin Manifolds

By Industry

Logistics - Palletizing / Sheet Metal - Stamping - Metal Fabrication

Assembling Tools

Tool / Jig

Information

Various Products Information



Rectangular Tube Series Parts

Securely fixes the Let's SUS square pipe by precision processing.

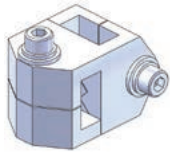

Cross connector • 10-20

Order code No.	185126
TYPE	S-CROSS 10-20

● Weight : 102g

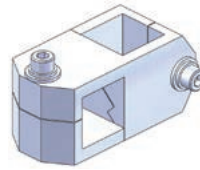
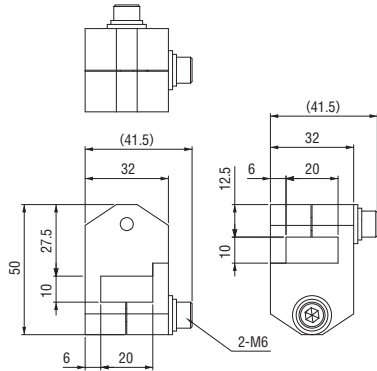

Cross connector • 25-25

Order code No.	185127
TYPE	S-CROSS 25-25

● Weight : 170g

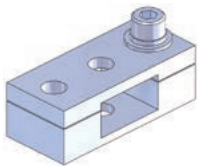
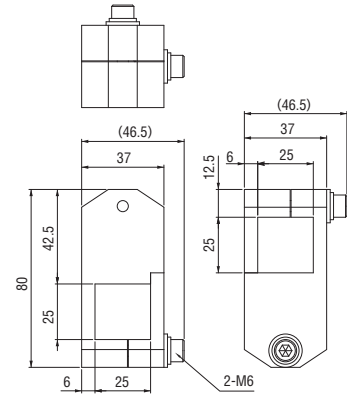

Attachment bracket • 10-20 • M6

Order code No.	185128
TYPE	S-ATBR 10-20 • M6

● Weight : 30g

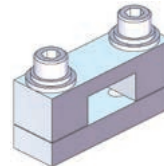
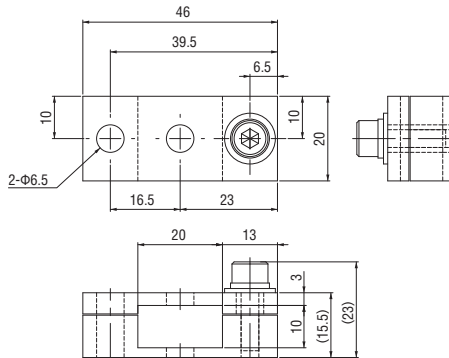

Slide bracket • 10-20

Order code No.	185129
TYPE	S-SLBR 10-20

● Weight : 55g

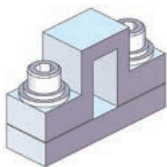
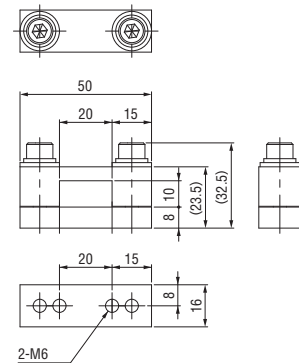

Slide bracket • 20-10

Order code No.	185130
TYPE	S-SLBR 20-10

● Weight : 57g

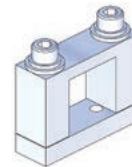
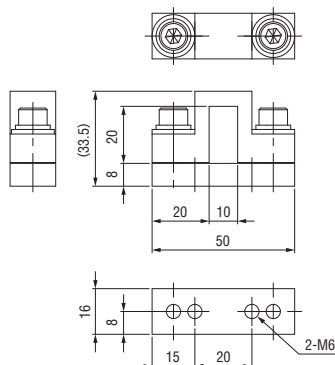

Slide bracket • 25-25

Order code No.	185131
TYPE	S-SLBR 25-25

● Weight : 73g

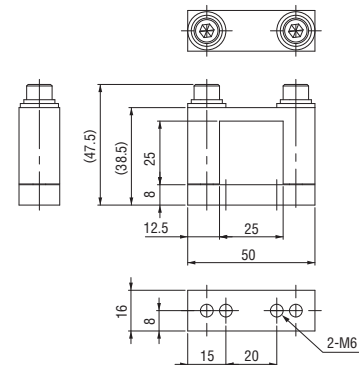

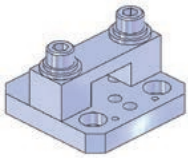

Bracket • 10 • MCD

Order code No.	185132
TYPE	S-BR10 MCD

● Weight : 87g

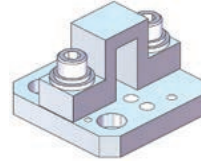
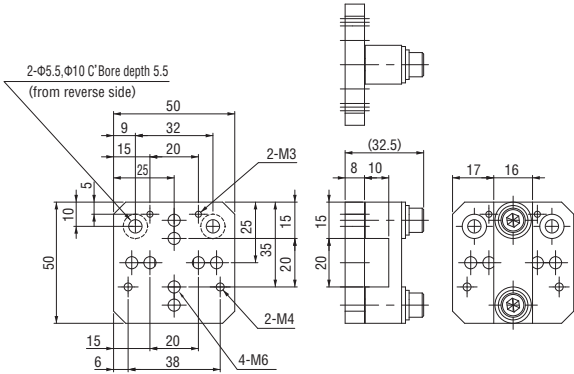

Bracket • 20 • MCD

Order code No.	185133
TYPE	S-BR20 MCD

● Weight : 90g

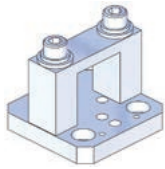
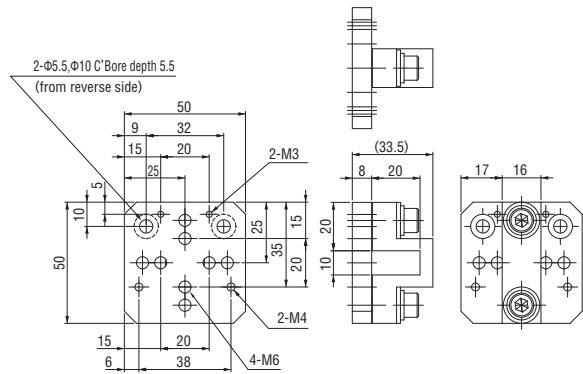

Bracket • 25 • MCD

Order code No.	185134
TYPE	S-BR25 MCD

● Weight : 105g

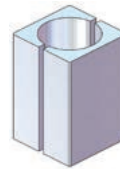
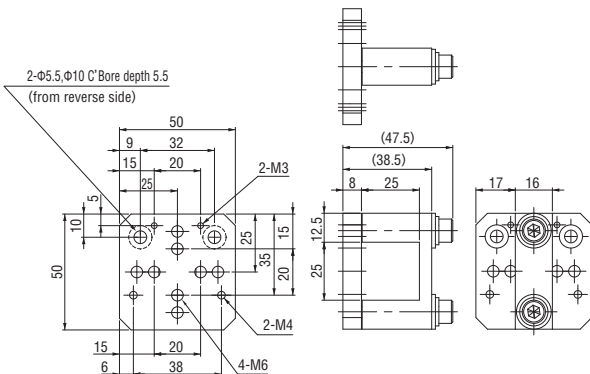

Conversion block • 25- φ 20

Order code No.	185135
TYPE	S-CBL25-D20

● Weight : 31g

Convert to rectangular tube 25x25 inner dimension to jungle gym φ 20.

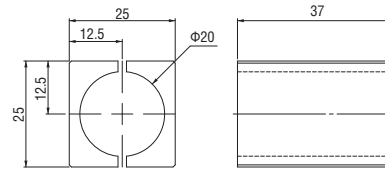

Notes on use

Reverse attachment prevents fixing of conversion block.

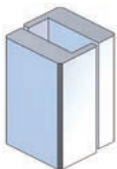
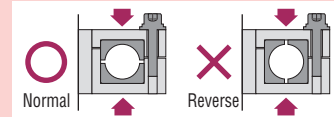

Conversion block • 25-10-20

Order code No.	185136
TYPE	S-CBL25-10-20

● Weight : 42g

Convert to rectangular tube 25x25 inner dimension to rectangular tube 10x20.

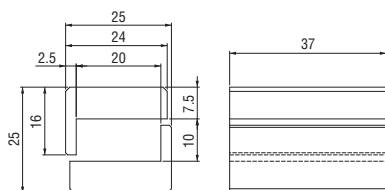

Notes on use

Reverse attachment prevents fixing of conversion block.

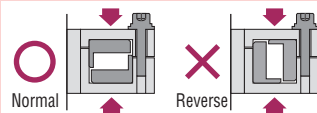

Leading connection

	Countermeasures	Page of details
Pitch 20-M3	Micro mini cylinders	2-4
Pitch 38-M4	Mini cylinder	2-4
Pitch 32-C'Bore	Mini container cylinder	2-19
Pitch 20-M6	Slide bracket φ 8, φ 12	5-15
	Slide bracket	5-21,22,23,24
	Nipper bracket	5-36
	Bracket • NCON	5-36

Quick Chuck Change

Quick Chuck Change Manual

Quick Chuck Change Manual (OM Type)

Tool Changer

Automated Hand Exchange System

Grip

Mini Cylinder

Accessories for Mini Cylinder

Container Cylinders

Accessories for Container Cylinder

Grippers

Rubber Material / Grip Pad

Suction

Suction Cups

Suction Stems

Pad in Pad

Vacuum Gripper

Air Ejector / Filter / Check Valve

Ultra Small Part Take Out

Vacuum Generator Unit

Cut

Air Nipper (Small-Medium)

Air Nipper (Large)

Frame / Module

Jungle Gym

Let's Joint

Rectangular Tube

Base Aluminum Material

Sliding Chuck

Pneumatic Components / Sensors

Pneumatic Components

Sensors / Multi AND Board

PCIO Communication Unit

Lightweight Parts Series

Frame / Suction / Resin Cylinders / Pads / Resin Manifolds

By Industry

Logistics-Palletizing/Sheet Metal-Stamping-Metal Fabrication

Assembling Tools

Tool / Jig

Information

Various Products Information

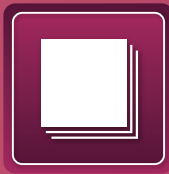

Base Aluminum Material

▶ Aluminum plate

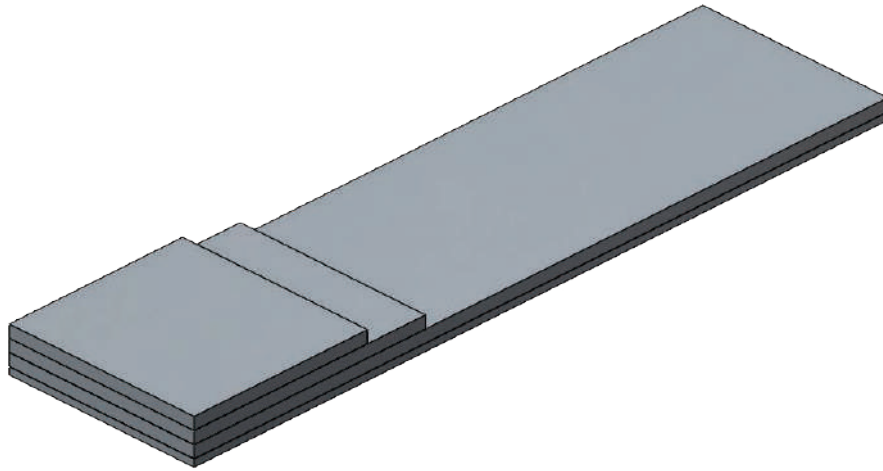

▶ Aluminum angle

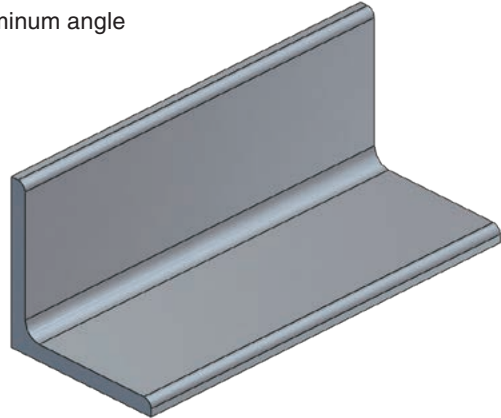

▶ Aluminum flat strip

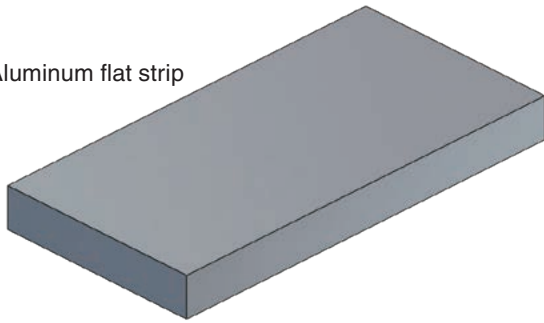

■ Specification

Product name	TYPE	Order code No.	Weight (g)	Remarks
Aluminum plate	3T*400*1200	370029	3,920	Material code : A5052
	5T*400*300	370028	1,630	Material code : A5052
	5T*400*400	370027	2,180	Material code : A5052
	5T*400*1200	370026	6,530	Material code : A5052
Aluminum angle	3T*30*30*2M	370074	900	Material code : A5052
	4T*40*40*2M	370075	1,670	Material code : A6063
	5T*30*30*2M	370077	1,400	Material code : A6063
	5T*50*50*2M	370076	2,440	Material code : A6063
Aluminum flat strip	10T*30*2M	370373	1,470	Material code : A6063
	10T*50*2M	370374	2,630	Material code : A6063

● The dimensional accuracy is +0.2mm.

► Aluminum angle

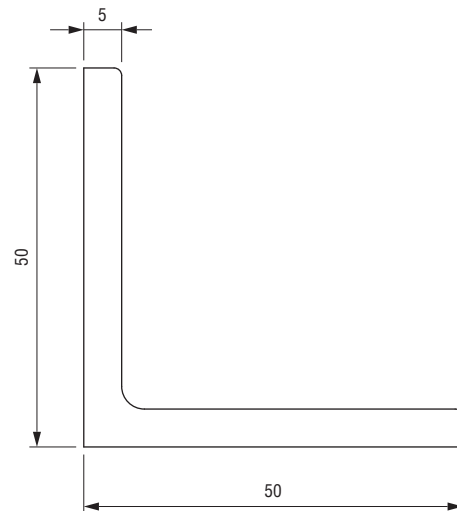
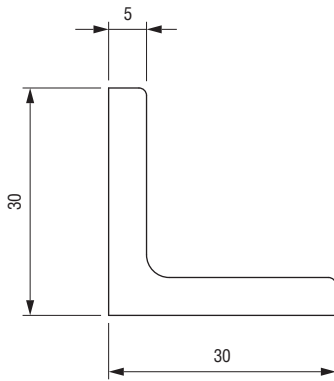
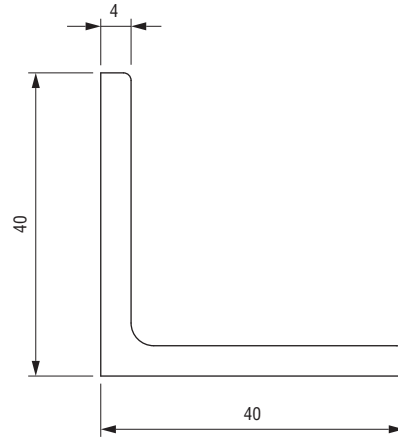
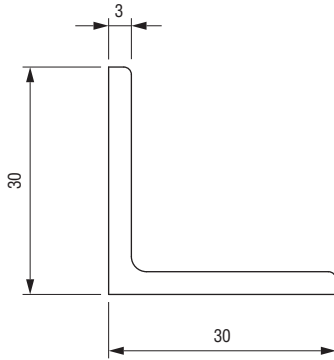

► Aluminum flat strip

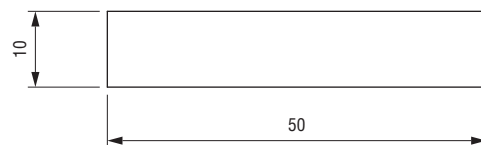
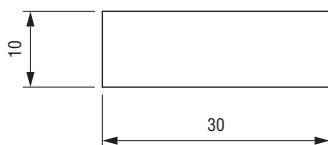

Quick Chuck Change

Quick Chuck Change Manual

Quick Chuck Change Manual (OM Type)

Tool Changer

Automated Hand Exchange System

Grip

Mini Cylinder

Accessories for Mini Cylinder

Container Cylinders

Accessories for Container Cylinder

Grippers

Rubber Material / Grip Pad

Suction

Suction Cups

Suction Stems

Pad in Pad

Vacuum Gripper

Air Ejector / Filter / Check Valve

Ultra Small Part Take Out

Vacuum Generator Unit

Cut

Air Nipper (Small-Medium)

Air Nipper (Large)

Frame / Module

Jungle Gym

Let's Joint

Rectangular Tube

Base Aluminum Material

Sliding Chuck

Pneumatic Components / Sensors

Pneumatic Components

Sensors / Multi AND Board

PCIO Communication Unit

Lightweight Parts Series

Frame / Section / Resin Cylinders / Pads / Resin Manifolds

By Industry

Logistics-Palletizing/Sheet Metal-Stamping-Metal Fabrication

Assembling Tools

Tool / Jig

Information

Various Products Information



Sliding Chuck

- ▶ Suction stem can be moved freely according to the shape of workpiece.
- ▶ The chuck mounting section is compatible with robots from other manufacturers.

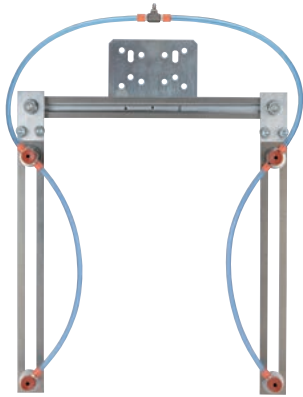

▶ Suction stems: for small
Sliding chuck

Order code No.	054285
TYPE	FCK1-0000

● Weight : 1,150g

Exploded view

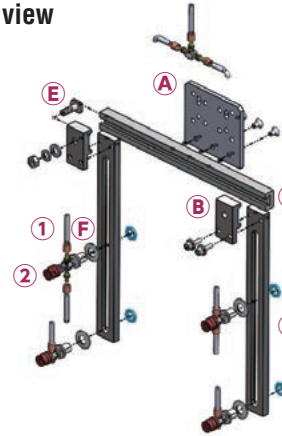

A Chuck mounting base

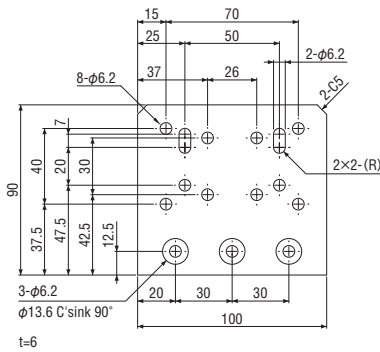

B Sliding holder

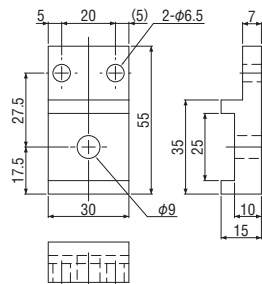

C Universal chuck slide base

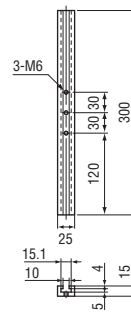
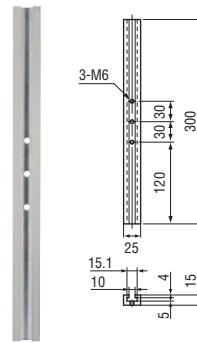

D Vertical bar (L)

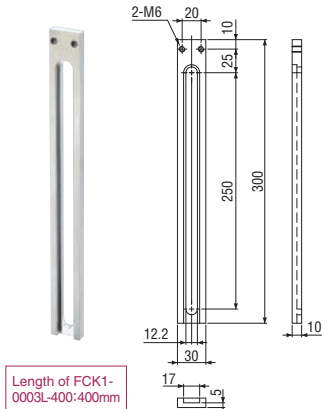
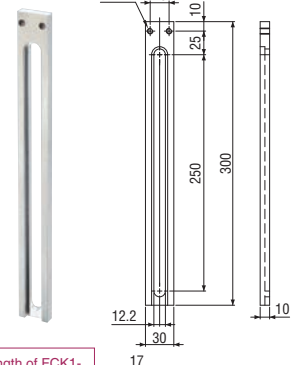

E Sliding chuck fastening bolt

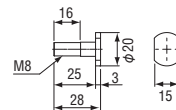

F Taper washer (small)

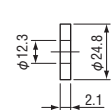
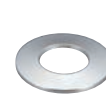

■ Specification

	Product name	TYPE	Order code No.	Weight (g)	Qty	
A	Chuck mounting base	FCK1-0001	054287	393	1	
B	Sliding holder	FCK1-0002S	054288	41	2	
C	Universal chuck slide base	FCK2-0004	054325	213	1	
D	Vertical bar (L)	300mm (standard)	FCK1-0003L	054289	139	2
		400mm	FCK1-0003L-400	054290	183	-
E	Sliding chuck fastening bolt	FCK1-0005	054326	11	2	
1	Suction stem for small (M5)	VFIL-S-5A	210974	20	4	
2	Suction cup (standard/silicon/brown)	VAPH-15C	210193	2.2	4	
F	Taper washer * for small	φ12 (for VFIL-S)	370244	4	4	

■ Information of used bolt

	Product name	TYPE	Order code No.	Qty
A+C	Flat head screw with hexagon socket	M6*10	122786	3
B+C	Nut class 1	M8	122783	2
	Spring washer	M8	122776	2
	Flat washer	M8	122781	2
B+D	Bolt with hexagon socket (SW+flat W)	M6*20	122822	4

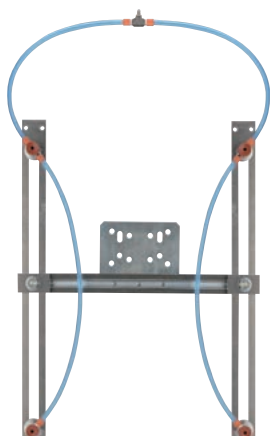

► Suction stems: for small
Universal chuck (H type)

Order code No. **054286**

TYPE **FCKH-0000**

● Weight : 1,185g

Exploded view

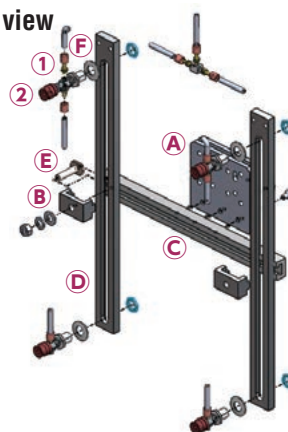

A Chuck mounting base

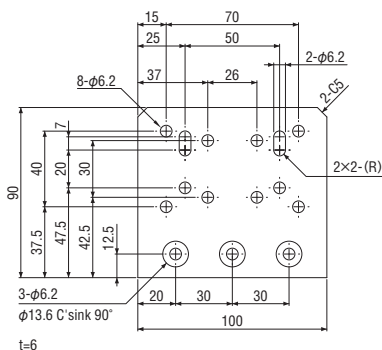

B Sliding holder H

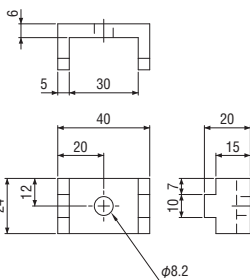

C Universal chuck slide base

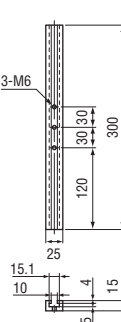
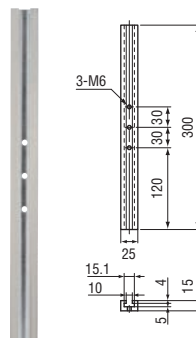

D Vertical bar (L)

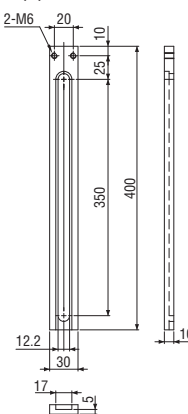
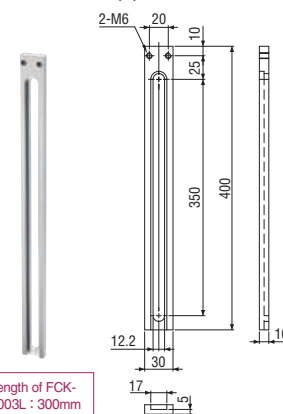

Length of FCK-0003L : 300mm

E Sliding chuck fastening bolt H

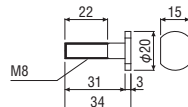

F Taper washer (small)

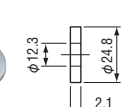

■ Specification

	Product name	TYPE	Order code No.	Weight (g)	Qty	
A	Chuck mounting base	FCK1-0001	054287	393	1	
B	Sliding holder H	FCKH-0007	054291	21	2	
C	Universal chuck slide base	FCK2-0004	054325	213	1	
D	Vertical bar (L)	400mm (standard)	FCK1-0003L-400	054290	183	2
		300mm	FCK1-0003L	054289	139	—
E	Sliding chuck fastening bolt H	FCKH-0005L	054292	16	2	
1	Suction stem for small (M5)	VFIL-S-5A	210974	20	4	
2	Suction cup (standard/silicon/brown)	VAPH-15C	210193	2.2	4	
F	Taper washer • for small	φ12 (for VFIL-S)	370244	4	4	

■ Information of used bolt

	Product name	TYPE	Order code No.	Qty
A+C	Flat head screw with hexagon socket	M6*10	122786	3
		Nut class 1	M8	122783
B+C	Spring washer	M8	122776	2
		Flat washer	M8	122781

Quick Chuck Change

Quick Chuck Change Manual

Quick Chuck Change Manual (OM Type)

Tool Changer

Automated Hand Exchange System

Grip

Mini Cylinder

Accessories for Mini Cylinder

Container Cylinders

Accessories for Container Cylinder

Grippers

Rubber Material / Grip Pad

Suction

Suction Cups

Suction Stems

Pad in Pad

Vacuum Gripper

Air Ejector / Filter / Check Valve

Ultra Small Part Take Out

Vacuum Generator Unit

Cut

Air Nipper (Small-Medium)

Air Nipper (Large)

Frame / Module

Jungle Gym

Let's Joint

Rectangular Tube

Base Aluminum Material

Sliding Chuck

Pneumatic Components / Sensors

Pneumatic Components

Sensors / Multi AND Board

PCIO Communication Unit

Lightweight Parts Series

Frame / Suction / Resin Cylinders / Pads / Resin Manifolds

By Industry

Logistics - Palletizing / Sheet Metal - Stamping - Metal Fabrication

Assembling Tools

Tool / Jig

Information

Various Products Information

Sliding Chuck

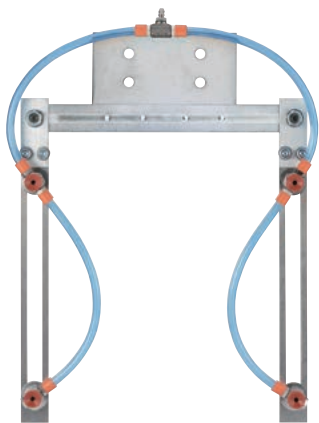

▶ Suction stem mini
Sliding chuck (mini)

Order code No. **054324**
TYPE **FCK1-1000**

● Weight : 616g

Exploded view

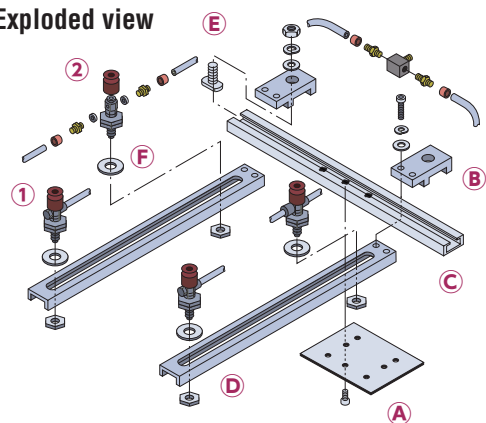

A Chuck mounting base

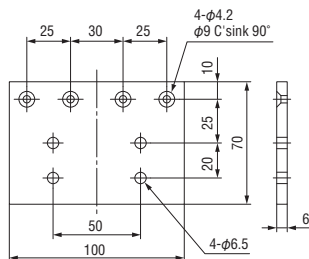

C Universal chuck slide base

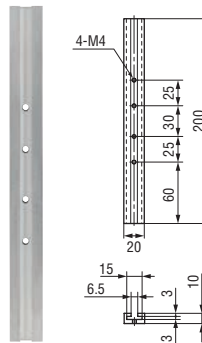

D Vertical bar

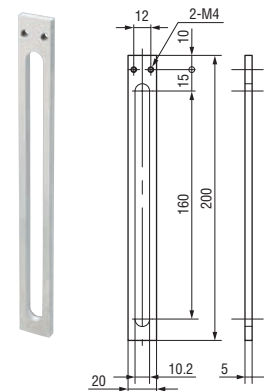

B Sliding holder

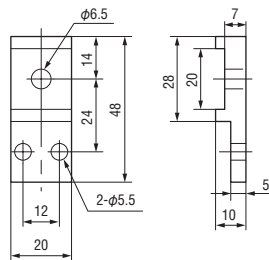

★ Sliding holder

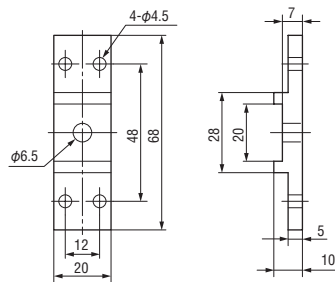

E Sliding chuck fastening bolt

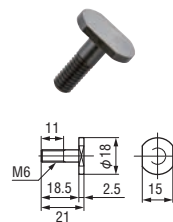

F Taper washer (mini)

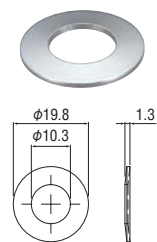

* Used to change to H type.

■ Specification

	Product name	TYPE	Order code No.	Weight (g)	Qty
A	Chuck mounting base	FCK1-1001	054340	313	1
B	Sliding holder	FCK1-1002	054321	16	2
C	Universal chuck slide base	FCK-1004	370735	69	1
D	Vertical bar 200mm	FCK1-1003	054322	32	2
E	Sliding chuck fastening bolt	FCK-1005	370736	8	2
1	Suction cups (standard/silicon/brown)	VAPH-12C	210192	0.8	4
2	Suction stem mini	VFIL1-SS-5	211029	14	4
F	Taper washer * for mini	φ10 (for VFIL-SS)	371362	1.9	4
★	Sliding holder	FCK1-1006	054323	18	—

* Used to change to H type.

■ Information of used bolt

	Product name	TYPE	Order code No.	Qty
A+C	Flat head screw with hexagon socket	M4*8	122785	4
	Nut class 1	M6	122782	2
B+C	Spring washer	M6	122775	2
	Flat washer	M6	122780	2
B+D	Bolt with hexagon socket (SW+flat W)	M4*12	122812	4

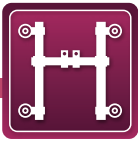

Robot Hand (for Articulated Robot)

Capable of handling a large number of workpieces in a short amount time.

Robot hand



You can see moving images of products by using QR code reader of your smartphone

- ▶ The suction stem could be easily moved to match the contours of the workpieces.
- ▶ The scale is marked on the SUS pipe.
- ▶ It can fulfill a variety of purposes when combined with chuck parts.



Quick Chuck Change

Quick Chuck Change Manual

Quick Chuck Change Manual (OM Type)

Tool Changer

Automated Hand Exchange System

Grip

Mini Cylinder

Accessories for Mini Cylinder

Container Cylinders

Accessories for Container Cylinder

Grippers

Rubber Material / Grip Pad

Suction

Suction Cups

Suction Stems

Pad in Pad

Vacuum Gripper

Air Ejector / Filter / Check Valve

Ultra Small Part Take Out

Vacuum Generator Unit

Cut

Air Nipper (Small-Medium)

Air Nipper (Large)

Frame / Module

Jungle Gym

Let's Joint

Rectangular Tube

Base Aluminum Material

Sliding Chuck

Pneumatic Components / Sensors

Pneumatic Components

Sensors / Multi AND Board

PCIO Communication Unit

Lightweight Parts Series

Frame / Suction / Resin Cylinders / Pads / Resin Manifolds

By Industry

Logistics - Palletizing / Sheet Metal - Stamping - Metal Fabrication

Assembling Tools

Tool / Jig

Information

Various Products Information

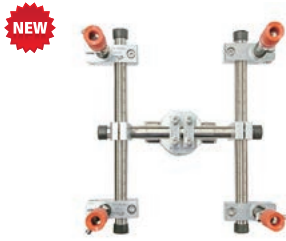

Robot hand

Order code No.	171372
TYPE	RHK10-150

- Weight : 490g
- Suction cups : VAPH-15C-3 (4pcs)
- Air supply port : Rc 1/8
- Mounting pitch (mm) : P.C.D 31.5
- Mounting boss diameter (mm) : outer diameter $\phi 20$, height 2.5
- Positioning pin holes (mm) : $\phi 4 \cdot \phi 5$
- Suction stem pitch (mm) : 50-150

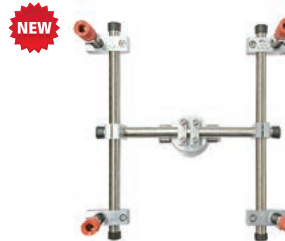
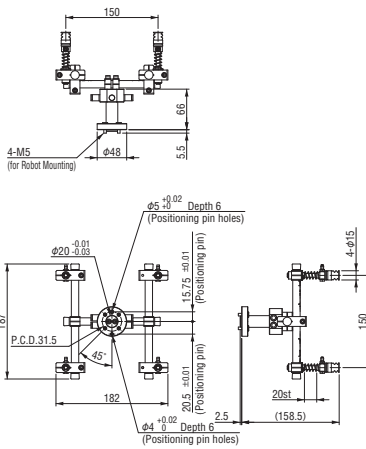

Robot hand

Order code No.	171373
TYPE	RHK10-200

- Weight : 545g
- Suction cups : VAPH-15C-3 (4pcs)
- Air supply port : Rc 1/8
- Mounting pitch (mm) : P.C.D 31.5
- Mounting boss diameter (mm) : outer diameter $\phi 20$, height 2.5
- Positioning pin holes (mm) : $\phi 4 \cdot \phi 5$
- Suction stem pitch (mm) : 100-200

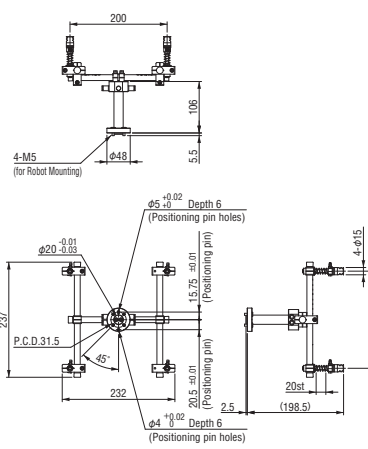

Robot hand

Order code No.	171374
TYPE	RHK10-250

- Weight : 612g
- Suction cups : VAPH-15C-3 (4pcs)
- Air supply port : Rc 1/8
- Mounting pitch (mm) : P.C.D 31.5
- Mounting boss diameter (mm) : outer diameter $\phi 20$, height 2.5
- Positioning pin holes (mm) : $\phi 4 \cdot \phi 5$
- Suction stem pitch (mm) : 150-250

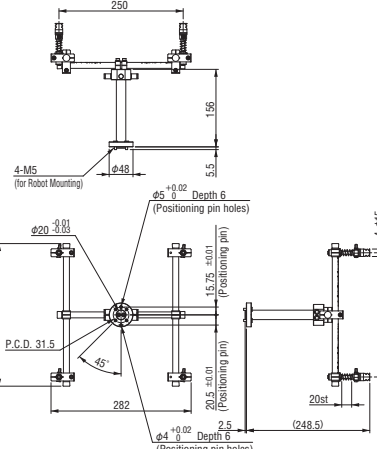

Mounting flange

Order code No.	171375
TYPE	RHK10-FA

- Weight : 41.6g
- Mounting pitch (mm) : P.C.D 31.5
- Mounting boss diameter (mm) : no (Flat)
- Positioning pin holes (mm) : $\phi 4 \cdot \phi 5$
- Mounting bolt : M5

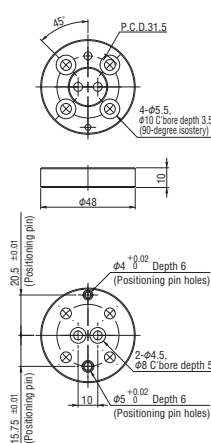

Mounting flange

Order code No.	171376
TYPE	RHK10-FB

- Weight : 41.8g
- Mounting pitch (mm) : P.C.D 31.5
- Mounting boss diameter (mm) : outer diameter $\phi 12$, height 2.5
- Positioning pin holes (mm) : $\phi 4 \cdot \phi 5$
- Mounting bolt : M5

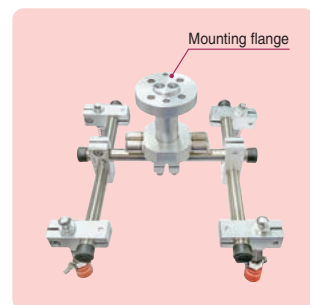
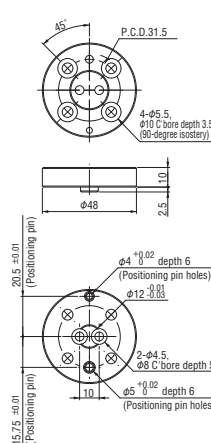

MEMO

A series of horizontal dashed lines for writing.