

Suction



Suction Cups 3-2

- ▶ Material Properties and Recomend Uses 3-3
- ▶ Suction Cups (Standard / Screw Mount Type) 3-4
- ▶ Suction Cups (Bellows / TR / TRN) 3-6
- ▶ Suction Cups w/ Sponge 3-7
- ▶ Suction Cups (Flat Face / Free / EP sponge) / Suction Stems Covers (Mini / Small) 3-8
- ▶ Accessories for Suction Cups 3-9
- ▶ Suction Cups (Fluorine Bellows / Sheet Metal) 3-10
- ▶ Suction Cups (Vacuum) 3-11
- ▶ Suction Cups (Multistage Bellows) 3-12
- ▶ Suction Cups (Pouches) 3-13
- ▶ Non-Contact Suction Pad 3-14
- ▶ Flat Suction Cups 3-15
- ▶ Bellows Type Suction Cups 1.5-stage 3-17
- ▶ Bellows Type Suction Cups 2.5-stage 3-18
- ▶ Oval Cups 3-19
- ▶ Sheet Metal Suction Cups 3-20
- ▶ Suction Cups for Exchange 3-21



Suction Stems 3-22

- ▶ Suction Stems (Micro / Mini / Small / Large) 3-23
- ▶ Suction Stems Non-Rotate (Micro / Mini / Small / for 1/8 Connection / Angle Adjustment / Large) 3-30
- ▶ Suction Stems with Locking Mechanism 3-32
- ▶ Suction Stems Attachment Head 3-33
- ▶ Suction Stems ↔ Suction Cups Selection Table 3-34
- ▶ Suction Stems Fixed / for Mini Cylinde 3-36
- ▶ Adjuster 3-37
- ▶ Suction Stems Angle Brackets 3-38



Pad in Pad 3-40

- ▶ Inner Stems / Outside Stems 3-40
- ▶ Inner Cup / Outside Cup / Test Kit 3-41
- ▶ Pad in Pad Selection List 3-42



Vacuum Gripper 3-44



Air Ejector / Filter / Check Valve ... 3-46

- ▶ Air Ejectors 3-47
- ▶ Small Air Filters 3-48
- ▶ Plastic Ejector Nozzles 3-49
- ▶ Small Check Valve for Suction Cup 3-50



Ultra Small Part Take Out 3-52



Vacuum Generator Unit 3-54

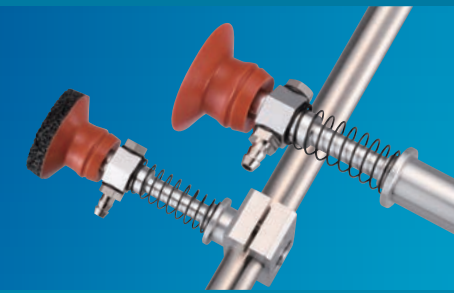
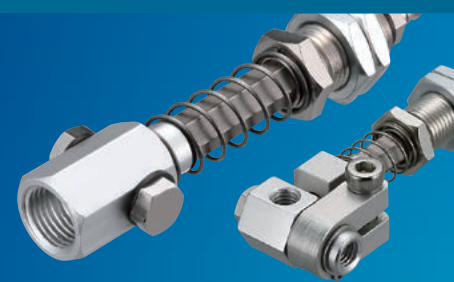

Quick Chuck Change

Quick Chuck Change Manual

Quick Chuck Change Manual (OM Type)

Tool Changer

Automated Hand Exchange System

Grip

Mini Cylinder

Accessories for Mini Cylinder

Container Cylinders

Accessories for Container Cylinder

Grippers

Rubber Material / Grip Pad

Suction

Suction Cups

Suction Stems

Pad in Pad

Vacuum Gripper

Air Ejector / Filter / Check Valve

Ultra Small Part Take Out

Vacuum Generator Unit

Cut

Air Nipper (Small-Medium)

Air Nipper (Large)

Frame / Module

Jungle Gym

Let's Joint

Rectangular Tube

Base Aluminum Material

Sliding Chuck

Pneumatic Components / Sensors

Pneumatic Components

Sensors / Multi AND Board

PCIO Communication Unit

Lightweight Parts Series

Frame / Suction / Mini Cylinder / Pads / Pouch Materials

By Industry

Legends - Pickling / Steel Metal Clamping / Metal Fabrication

Assembling Tools

Tool / Jig

Information

Various Products Information



Please check the performance table on the web site.

Suction Cups (Standard / Screw Mount Type)



The most suitable one can be selected from wide range of products.

3-4

Suction Cups (Bellows / TR / TRN)



Use bellows cups for medium-sized angled parts. Fluorine type is also available. The most suitable one can be selected from wide range of products.

3-6

Suction Cups w/ Sponge



Use with parts with uneven suction surfaces. (For work piece with small unevenness)

3-7

Suction Cups (Flat Face/Bellows/w/ EP Sponge)



- Use for parts that are not easily released or require additional support. Also good with IML applications.
- Used for Angled parts
- Use with parts with uneven suction surfaces. (For work piece with big unevenness)

3-8

Suction Stems Covers (Mini / Small)



Used as a cap when suction cup is not used.

3-8

Accessories for Suction Cups



Stick it to the end of the suction cup according to its use.

3-9

Suction Cups(Fluorine Bellows/for Steel Sheet)



- Used for Angled parts
- for sheet metal conveyance.

3-10

Suction Cups(Vacuum/Multistage Bellows)



Supports work with high cushioning and unevenness.

3-11

Suction Cups (Pouches/Non-Contact Suction Pad)



Perfect for soft or bag shape workpiece.

3-13

Suction Cups(Flat /Bellows)



Flat basic type. Silicone type and a mark-free type are provided.

3-15

Oval Cups



Oval type. There are silicone and mark-less types.

3-19

Sheet Metal Suction Cups



Strong holding power in the horizontal direction and excellent balance of stability. Excellent follow-up ability to a curved surface. Excellent durability with original material.

3-20

Pad in Pad



Perfect for the parts that have holes. The pad within the assembly can effectively seal the central opening of the workpiece. It can be positioned to cover the hole located at the center of the component.

3-40

Vacuum Gripper



A single gripper could use for different shape of work piece.

3-44

Cup for Air Ejectors



Please use with air ejectors.

3-47



Please check the performance table on the web site.

Theoretical suction power of suction cups

The theoretical suction power can be obtained with the area of cup and the degree of vacuum caused by using the cup.

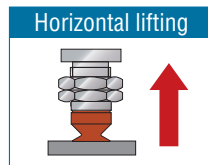

● kPa, N display

$$W = \frac{C \times P}{101} \times 10.13 \times f$$

● mmHg, Kg display

$$W = \frac{C \times P}{760} \times 1.0332 \times f$$

W : Theoretical suction power (N) · (Kg) C : Area of cup (cm²)
P : Degree of vacuum (-kPa) · (-mmHg) f : Safety factor

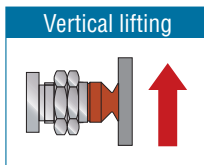

Since the theoretical suction power is a value under static conditions, use the safety factor of 1/4 for horizontal lifting and 1/8 for vertical lifting in practical use. Also for movement, take acceleration caused by the movement into consideration.

● General type cup (rubber cup)

*Safety factor is not considered.

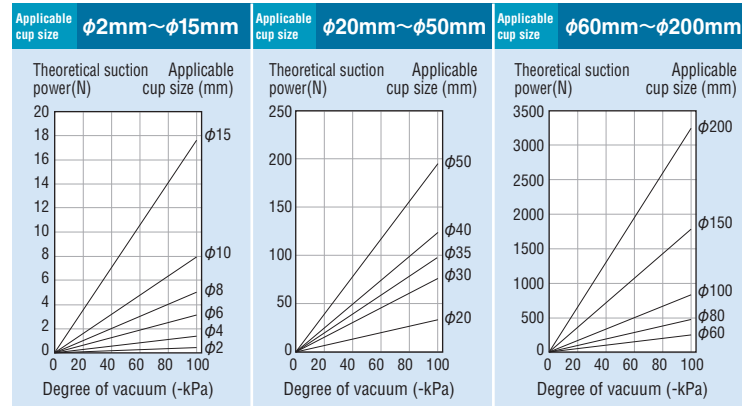

Pad Shape and Uses

Pad shape	Uses
Flat type	If the surface of the part is flat and has no deformation.
Flat type (with rib)	<ul style="list-style-type: none"> ● Part is easy to deform. ● Good for releasing the Part.
Groove	<ul style="list-style-type: none"> ● Used for when the part has an oil film and is slippery. ● Used for parts that are curved.
Oval	Used for parts that have little suction surface and/or are long and unstable.

Pad shape	Uses
Bellows	<ul style="list-style-type: none"> ● Used when there is no space for installing buffer. ● Suction surface is slanted. ● The surface is curved.
w/ Sponge	Parts with uneven suction surface.
Pouches	Film packaging and soft parts.
Non contact	For when printed circuit board and acrylic board, etc. cannot be absorbed and transported.

Properties of rubber used in our suction cups

○ : suitable △ : Can be used according to the condition (specification). × : Not suitable

Characteristics	Material	Silicone (brown)	Silicone (transparent white, white)	Urethane (milk white)	Fluorine (black)	Nitrile (green)	Mark-free (blue)
Heat-resistance (°C)		-60~250		-20~75	-10~230	-30~150	-10~140
Shore hardness (HS)		54~80		55	65	50	60
No mark of cup left		×		×	○	○	○
Food		×/○		×	×	×	×
Food packaging		○		○	○	○	○
Oil resistance		×		○	○	○	○
Weight		△		○	△	○	△
Antistatic agent		△		×	△	×	×
Rough surface (stone or wood)		×		○	×	×	×
Glass		×		○	○	×	○
Alcohol resistance		○		△	△	○	○
Acid resistance		△		×	○	△	×

● Above shows the general characteristics of rubber, only. Check the shape of suction cup and operating conditions.

* Silicon pad (whitish transparent) conforms to the U.S. food and drug administration (FDA) and BfR (German Federal Institute for Risk Assessment) standard.

Quick Chuck Change

Quick Chuck Change Manual

Quick Chuck Change Manual (OM Type)

Tool Changer

Automated Hand Exchange System

Grip

Mini Cylinder

Accessories for Mini Cylinder

Container Cylinders

Accessories for Container Cylinder

Grippers

Rubber Material / Grip Pad

Suction

Suction Cups

Suction Stems

Pad in Pad

Vacuum Gripper

Air Ejector / Filter / Check Valve

Ultra Small Part Take Out

Vacuum Generator Unit

Cut

Air Nipper (Small-Medium)

Air Nipper (Large)

Frame / Module

Jungle Gym

Let's Joint

Rectangular Tube

Base Aluminum Material

Sliding Chuck

Pneumatic Components / Sensors

Pneumatic Components

Sensors / Multi AND Board

PCIO Communication Unit

Lightweight Parts Series

Frame / Suction / Resin Cylinders / Pads / Resin Manifolds

By Industry

Logistics-Palletizing/Sheet Metal-Stamping-Metal Fabrication

Assembling Tools

Tool / Jig

Information







Various Products Information





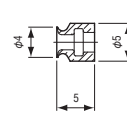
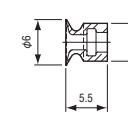
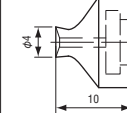
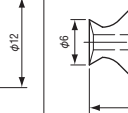
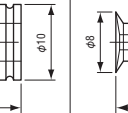
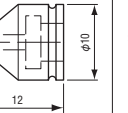

Suction Cups (Standard/Screw Mount Type)

Utilize it as per your requirements from a range of products.

- Reinforced silicone** Excellent in durability and heat resistance (250°C).
- Urethane** Excellent in durability, oil resistance, chemical resistance, and flexible.
- Fluorine** The material exhibits outstanding durability, resistance to heat and chemicals, and is not prone to leaving suction marks, ensuring a prolonged service life.
- Nitrile** Excellent durability, heat resistant and chemical resistance, mostly resistant to suction marks and has long service life.

Applicable cup size	φ 4mm	φ 6mm	φ 4mm	φ 6mm	φ 8mm	φ 10mm	
Suction Cups (standard)	 * Micro	 * Micro					
Drawing							
Reinforced silicone (brown)	Order code No.	210789	210790	210700	210255	210191	210615
	TYPE	VAPH-4M	VAPH-6M	VAPH-4C	VAPH-6C	VAPH-8C	VAPH-10C
	Weight	0.2g	0.3g	0.4g	0.5g	0.6g	0.7g
Urethane (milk white)	Order code No.	—	—	210701	210395	210396	210703
	TYPE	—	—	VAPU-4C	VAPU-6C	VAPU-8C	VAPU-10C
	Weight	—	—	0.4g	0.6g	0.7g	0.7g
Fluorine (black)	Order code No.	—	—	210702	210402	210403	210704
	TYPE	—	—	VAPF-4C	VAPF-6C	VAPF-8C	VAPF-10C
	Weight	—	—	0.9g	0.9g	1.0g	1.0g
Nitrile (green)	Order code No.	—	—	210791	210792	210793	210794
	TYPE	—	—	VAPN-4C	VAPN-6C	VAPN-8C	VAPN-10C
	Weight	—	—	0.7g	0.7g	0.6g	0.6g
Applicable stems	Micro : VFILB-M, MSH → 3-23,30			Mini : VFILB-SS, or VFILB-SSH → 3-23,24,25,30			

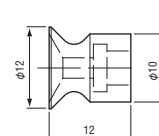
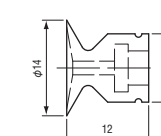
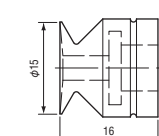
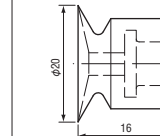
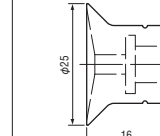
Applicable cup size	φ 12mm	φ 14mm	φ 15mm	φ 20mm	φ 25mm	
Suction Cups (standard)						
Drawing						
Reinforced silicone (brown)	Order code No.	210192	210616	210193	210194	210617
	TYPE	VAPH-12C	VAPH-14C	VAPH-15C	VAPH-20C	VAPH-25C
	Weight	0.8g	1.0g	2.2g	2.6g	3.3g
Urethane (milk white)	Order code No.	210397	210705	210398	210399	—
	TYPE	VAPU-12C	VAPU-14C	VAPU-15C	VAPU-20C	—
	Weight	0.8g	0.8g	2.4g	2.8g	—
Fluorine (black)	Order code No.	210404	210706	210405	210406	—
	TYPE	VAPF-12C	VAPF-14C	VAPF-15C	VAPF-20C	—
	Weight	1.2g	1.2g	3.5g	3.8g	—
Nitrile (green)	Order code No.	210795	210796	210797	210798	—
	TYPE	VAPN-12C	VAPN-14C	VAPN-15C	VAPN-20C	—
	Weight	1.0g	1.0g	3.1g	3.3g	—
Applicable stems	Mini : VFIL-SS, or VFILB-SSH → 3-23,24,25,30			Small : VFIL-S, or VFILB-SH → 3-26,27,28,30		

Quick Chuck Change

Quick Chuck Change Manual

Quick Chuck Change Manual (OM Type)

Tool Changer

Automated Hand Exchange System

Grip

Mini Cylinder

Accessories for Mini Cylinder

Container Cylinders

Accessories for Container Cylinder

Grippers

Rubber Material / Grip Pad

Suction
Suction Cups

Suction Stems

Pad in Pad

Vacuum Gripper

Air Ejector / Filter / Check Valve

Ultra Small Part Take Out

Vacuum Generator Unit

Cut

Air Nipper (Small-Medium)

Air Nipper (Large)

Frame / Module

Jungle Gym

Let's Joint

Rectangular Tube

Base Aluminum Material

Sliding Chuck

Pneumatic Components / Sensors

Pneumatic Components

Sensors / Multi AND Board

PCIO Communication Unit

Lightweight Parts Series

Frame / Suction / Resin Cylinders / Pads / Resin Manifolds

By Industry





Logistics-Palletizing/Sheet Metal-Stamping-Metal Fabrication





Assembling Tools

Tool / Jig

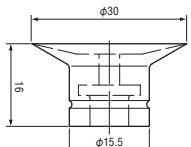
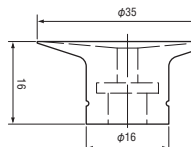
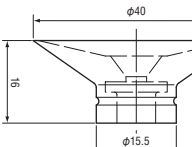
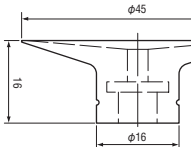
Information

Various Products Information

Applicable cup size	φ 30mm	φ 35mm	φ 40mm	φ 45mm
Suction Cups (standard)				
Drawing				
Reinforced silicone (brown)	Order code No.	210195	210618	210196
	TYPE	VAPH-30C	VAPH-35C	VAPH-40C
	Weight	3.6g	4.0g	5.7g
Urethane (milk white)	Order code No.	210400	—	210401
	TYPE	VAPU-30C	—	VAPU-40C
	Weight	3.6g	—	6.0g
Fluorine (black)	Order code No.	210407	—	210408
	TYPE	VAPF-30C	—	VAPF-40C
	Weight	5.5g	—	8.8g
Nitrile (green)	Order code No.	210799	—	210800
	TYPE	VAPN-30C	—	VAPN-40C
	Weight	4.6g	—	7.6g
Applicable stems	Small : VFIL-S, or VFILB-SH → 3-26,27,28,30			

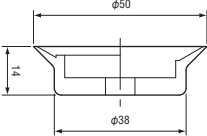
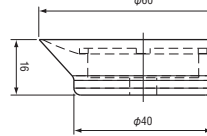
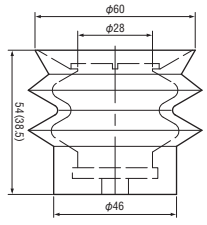
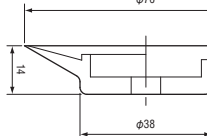
Applicable cup size	φ 50mm	φ 60mm	φ 60mm	φ 70mm
Suction cups (screw mount type)				
Drawing			 * The value in () indicates the dimension with suction.	
Reinforced silicone (brown)	Order code No.	210619	210311	210044
	TYPE	VAPH-50F	VAPH-60F	VAPH-60F-2
	Weight	11.0g	17.0g	73.0g
Fluorine (black)	Order code No.	—	210417	—
	TYPE	—	VAPF-60F	—
	Weight	—	28.0g	—
Nitrile (green)	Order code No.	—	210801	—
	TYPE	—	VAPN-60F	—
	Weight	—	23.8g	—
Applicable stems	Large : VFI-L, or VFIL-H → 3-29,31			



Suction Cups (Bellows/TR/TRN)

Utilize it as per your requirements from a range of products.

Reinforced silicone Excellent in durability and heat resistance (250°C). **Nitrile** Excellent durability, heat resistant and chemical resistance, mostly resistant to suction marks and has long service life.

► Used for parts with curved surfaces and angles. Bring parts closer with the bellows distance.

Applicable cup size	φ3mm	φ15mm	φ20mm	φ30mm	φ40mm
Suction cups (Bellows)					
Drawing					
Reinforced silicone (brown)	Order code No.	210897	210697	210661	210662
	TYPE	VAPH-3C-3	VAPH-15C-3	VAPH-20C-3	VAPH-30C-3
	Weight	1.0g	2.7g	2.9g	7.0g
Applicable stems	Micro : VFILB-M,MSH → 3-23,30		Small : VFIL-S, or VFILB-SH → 3-26,27,28,30		

► Use for parts with curved surfaces and angles. Demonstrates the ability to follow the part's angle.

Applicable cup size	φ6mm	φ8mm	φ10mm	φ12mm
Suction cups (TR/TRN)				
Drawing				
Reinforced silicone (brown)	Order code No.	196327	196342	196406
	TYPE	TR-1062-1M	TR-1062-2M	TR-1062-3M
	Weight	1.0g	1.0g	1.0g
Nitrile (green)	Order code No.	196403	196401	196399
	TYPE	TRN-1062-1M	TRN-1062-2M	TRN-1062-3M
	Weight	1.4g	1.4g	1.4g
Applicable stems	Mini : VFIL-SS, or VFILB-SSH → 3-23,24,25,30			

Applicable cup size	φ6mm	φ8mm	φ10mm	φ12mm
Suction cups (TR/TRN)				
Drawing				
Reinforced silicone (brown)	Order code No.	193511	193512	196135
	TYPE	TR-1062-1	TR-1062-2	TR-1062-3
	Weight	1.0g	1.0g	1.0g
Nitrile (green)	Order code No.	196404	196402	196398
	TYPE	TRN-1062-1	TRN-1062-2	TRN-1062-3
	Weight	1.4g	1.4g	1.4g
Applicable stems	Small : VFIL-S, or VFILB-SH → 3-26,27,28,30			



Suction Cups w/ Sponge

Used for work pieces with uneven suction surfaces. (For work piece with small unevenness)

- Please inquire for more information on cups with sponges of other sizes.
- Sponge material: closed-cell foam silicone
- Heat resistance (continuously used for a long time): 150°C

Applicable cup size	φ8mm	φ12mm	φ15mm	φ20mm	φ30mm	
Suction Cups (w/ sponge)						
Drawing						
Reinforced silicone (brown)	Order code No.	210664	210665	210534	210535	210536
	TYPE	VAPH-8C-SP	VAPH-12C-SP	VAPH-15C-SP	VAPH-20C-SP	VAPH-30C-SP
	Weight	0.7g	0.9g	2.6g	2.9g	4.8g
	Heat-resistance	200°C			200°C	
Applicable stems	Mini : VFIL-SS, or VFILB-SSH → 3-23,24,25,30			Small : VFIL-S, or VFILB-SH → 3-26,27,28,30		

Applicable cup size	φ40mm	φ60mm	
Suction Cups (w/ sponge)		 ※ Screw Mount Type	
Drawing			
Reinforced silicone (brown)	Order code No.	210537	210538
	TYPE	VAPH-40C-SP	VAPH-60F-SP
	Weight	8.3g	22.0g
	Heat-resistance	200°C	
Applicable stems	Small : VFIL-S, or VFILB-SH → 3-26,27,28,30	Large : VFI-L, or VFIL-H → 3-29,31	

Applicable cup size	φ20mm	φ30mm	φ40mm	
Suction Cups (w/ sponge)				
Drawing				
Reinforced silicone (brown)	Order code No.	210914	210915	210916
	TYPE	VAPH-20C-10-3-SP	VAPH-30C-15-3-SP	VAPH-40C-20-3-SP
	Weight	3.0g	8.0g	19.0g
	Heat-resistance	200°C		
Applicable stems	Small : VFIL-S, or VFILB-SH → 3-26,27,28,30			

Quick Chuck Change

Quick Chuck Change Manual

Quick Chuck Change Manual (OM Type)

Tool Changer

Automated Hand Exchange System

Grip

Mini Cylinder

Accessories for Mini Cylinder

Container Cylinders

Accessories for Container Cylinder

Grippers

Rubber Material / Grip Pad

Suction

Suction Cups

Suction Stems

Pad in Pad

Vacuum Gripper

Air Ejector / Filter / Check Valve

Ultra Small Part Take Out

Vacuum Generator Unit

Cut

Air Nipper (Small-Medium)

Air Nipper (Large)

Frame / Module

Jungle Gym

Let's Joint

Rectangular Tube

Base Aluminum Material

Sliding Chuck

Pneumatic Components / Sensors

Pneumatic Components

Sensors / Multi AND Board

PCIO Communication Unit

Lightweight Parts Series

Frame / Section / Resin Cylinders / Pads / Resin Manifolds

By Industry

Logistics - Palletizing / Sheet Metal - Stamping - Metal Fabrication

Assembling Tools

Tool / Jig

Information

Various Products Information



Suction Cups (Flat Face/Free/EP sponge) / Suction Stems Covers (Mini/Small)

Utilize it as per your requirements from a range of products.

► Used for work pieces that are not released easily from suction cup.

Applicable cup size	φ 15mm	φ 20mm	
Suction Cups (flat face)			
Drawing			
Reinforced silicone (brown)	Order code No.	210389	210390
	TYPE	VAPH-15C-1	VAPH-20C-1
	Weight	2.0g	2.4g
Applicable stems	Small : VFIL-S, or VFILB-SH → 3-26,27,28,30		

► Used to be attached to the end of suction stem.

Applicable cup size	φ 10mm	φ 16mm	
Suction stems cover			
Drawing			
Reinforced silicone (brown)	Order code No.	211024	211023
	TYPE	VAPH-SSC	VAPH-SC
	Weight	0.35g	1.70g
Applicable stems	Mini : VFIL-SS, or VFILB-SSH → 3-23,24,25,30	Small : VFIL-S, or VFILB-SH → 3-26,27,28,30	

► Use bellows cups for medium-sized angled parts.

Applicable cup size	φ 12mm	φ 20mm	
Bellows cups (Free)			
Drawing			
Reinforced silicone (brown)	Order code No.	210280	210310
	TYPE	VAPH-12C-2	VAPH-20C-2
	Weight	1.1g	2.8g
Urethane (milk white)	Order code No.	210409	210410
	TYPE	VAPU-12C-2	VAPU-20C-2
	Weight	1.2g	3.0g
Fluorine (black)	Order code No.	210411	210412
	TYPE	VAPF-12C-2	VAPF-20C-2
	Weight	1.9g	4.3g
Nitrile (green)	Order code No.	210802	210803
	TYPE	VAPN-12C-2	VAPN-20C-2
	Weight	1.5g	3.9g
Applicable stems	Mini : VFIL-SS, or VFILB-SSH → 3-23,24,25,30	Small : VFIL-S, or VFILB-SH → 3-26,27,28,30	

* The value in () indicates the dimension with suction.
* The value in [] indicates the dimension for reinforced silicone.

► Used for work pieces with uneven suction surfaces. (For work pieces with uneven suction surfaces.)

Applicable cup size	φ 14mm	φ 20mm	φ 30mm	φ 40mm	
Suction Cups (EP sponge)					
Drawing					
Reinforced silicone (brown)	Order code No.	210859	210860	210861	210862
	TYPE	VAPH-14C-EPSP	VAPH-20C-EPSP	VAPH-30C-EPSP	VAPH-40C-EPSP
	Weight	1.1g	2.8g	4.0g	6.4g
	Heat-resistance	80°C		80°C	
Applicable stems	Mini : VFIL-SS, or VFILB-SSH → 3-23,24,25,30		Small : VFIL-S, or VFILB-SH → 3-26,27,28,30		

Applicable cup size	φ 50mm	φ 60mm	
Suction Cups (EP sponge)			
	* Screw Mount Type	* Screw Mount Type	
Drawing			
Reinforced silicone (brown)	Order code No.	210863	210864
	TYPE	VAPH-50F-EPSP	VAPH-60F-EPSP
	Weight	11.5g	18.2g
	Heat-resistance	80°C	
Applicable stems	Large : VFI-L, or VFI-H → 3-29,31		

Precautions for Suction Cup

- Double-stick tape is used for adhesion to EP sponge. Use silicon adhesive if the adhesive strength is low.
- Double-sided tape is weak when the oblique tension force is added. Use the tape for the vertical direction force.
- Your diagram may have a slightly different layout as the component is made of sponge.



Accessories for Suction Cups

Use as your situation.

▶ Static elimination sheet for suction cups surface.

Applicable cup size	φ 12mm	φ 15mm	φ 20mm	φ 30mm	φ 40mm
Pad diameter SD sheet					
Drawing					
Order code No.	271682	271683	282552	297701	300485
TYPE	12C-SD	15C-SD	20C-SD	30C-SD	40C-SD
Weight	1.0g	1.0g	1.0g	1.0g	1.0g
Heat-resistance	80°C				

* The introduction of leakage results in a 40% decrease in vacuum force once the SD sheet is applied. * With double-stick-tape processing.

▶ EP sponge sheet to be attached at the tip of the suction cup. Perfect for parts with uneven suction surfaces.

Applicable cup size	φ 14mm	φ 20mm	φ 30mm	φ 40mm	φ 50mm	φ 60mm
EP sponge (black)						
Drawing						
Order code No.	271559	282010	294889	300386	310589	322949
TYPE	14C-EPSP	20C-EPSP	30C-EPSP	40C-EPSP	50C-EPSP	60C-EPSP
Weight	0.1g	0.2g	0.4g	0.7g	0.5g	1.2g
Heat-resistance	80°C					

* Your diagram may have a slightly different layout as the component is made of sponge.
* Please use the code No. 286172 "cutter" for peeling sponge sheet film. (Please check the details on the website.)

▶ Sponge sheet to be attached at the tip of the Suction Cups (Bellow).

Applicable cup size	φ 40mm
Silicon sponge ring (Brown)	
Drawing	
Order code No.	072746
TYPE	40C-SP
Weight	1.0g
Heat-resistance	200°C

NEW



TOP SHEET CUTTER

Order code No.	286172
TYPE	209B

- Ideal for removing EP sponge sheet coatings. The spring built into the main body keeps constant pressure on the blade allowing for stable cutting action.



Adhesive (sponge Pads)

Order code No.	371759
TYPE	Adhesive Q 50G Clear #4888

- NET : 50ml
- Silicon bond
- Use for adhesion to rubber system.

NEW



Aluminum LAMIZIP

Order code No.	002407
TYPE	AL-22

- Please use this for storing suction cups.

Precautions for sticking (SD sheet, EP sponge)

- Use the purchases within one month after you buy them. Adhesive force of the double-sided tape will significantly reduce after stored for a long time. We recommend using with the silicone adhesive (371759 BATH BOND).
- Wipe the surface clean with ethanol before you stick it on the cup. Do not touch the surface with your hands.
- Hold the adhesive surface with sufficient adhesion to the surface for about 24 hours.
- If the adhesive strength is weak, please strengthen it with silicone adhesive (371759 bath bond).
- Double-sided tape is weak when the oblique tension force is added. Use the tape for the vertical direction force.

Precautions for sticking Sponge sheet

- When apply the parts, please wipe the surface with ethanol and spread the silicone adhesive then attaches the parts without touching. (371759 Bath Bond)

Quick Chuck Change

Quick Chuck Change Manual

Quick Chuck Change Manual (OM Type)

Tool Changer

Automated Hand Exchange System

Grip

Mini Cylinder

Accessories for Mini Cylinder

Container Cylinders

Accessories for Container Cylinder

Grippers

Rubber Material / Grip Pad

Suction

Suction Cups

Suction Stems

Pad in Pad

Vacuum Gripper

Air Ejector / Filter / Check Valve

Ultra Small Part Take Out

Vacuum Generator Unit

Cut

Air Nipper (Small-Medium)

Air Nipper (Large)

Frame / Module

Jungle Gym

Let's Joint

Rectangular Tube

Base Aluminum Material

Sliding Chuck

Pneumatic Components / Sensors

Pneumatic Components

Sensors / Multi AND Board

PCIO Communication Unit

Lightweight Parts Series

Frame / Suction / Resin Cylinders / Pads / Resin Manifolds

By Industry

Logistics-Palletizing/Sheet Metal-Stamping-Metal Fabrication

Assembling Tools

Tool / Jig

Information

Various Products Information



Suction Cups (Fluorine Bellows/Sheet Metal)

Use as your situation.

- Fluorine** The material exhibits outstanding durability, resistance to heat and chemicals, and is not prone to leaving suction marks, ensuring a prolonged service life.
- Nitrile** Excellent durability, heat resistant and chemical resistance, mostly resistant to suction marks and has long service life.

▶ Used for parts with angle. High temperature resistance and reduce suction cup markings.

Applicable cup size	φ3mm	φ15mm	φ20mm	φ30mm	φ40mm	
Suction Cups (Fluorine Bellows)						
Drawing						
* The value in () indicates the dimension with suction.						
Fluorine (black)	Order code No.	211101	042042	042043	042044	042045
	TYPE	VAPF-3C-3	EPCG-15-F	EPCG-20-F	EPCG-30-F	EPCG-40-F
	Weight	0.1g	3g	4g	14g	32g
Applicable head	Names	Suction stems head • M5 • For EPCG15/20			Suction stems head • M5 • For EPCG30/40	
	Order code No.	211102			211103	
	TYPE	VFILK-AH01			VFILK-AH02	
Weight	3.0g			8.0g		
Drawing						
Applicable stems	Micro : VFILB-M,MSH → 3-23,30			VFILB2-SH system (used by replacing the head) → 3-30		

* When using a fluorine pad φ 15 mm to φ 40 mm, a special suction head bracket is required.

▶ Use it for sheet metal conveyance. The grooves on the suction surface of the pad inhibit the lateral movement of the iron plate, which is coated with an oil film, while also accommodating the curved workpiece through a buffering effect.

Applicable cup size	φ30mm		φ60mm		
Suction Cups (Sheet Metal)					
Drawing					
* The value in () indicates the dimension with suction.					
Fluorine (black)	Order code No.	210918	210919	210920	210921
	TYPE	VAPNP-30C-1-M	VAPNP-30C-1-F	VAPNP-60C-1-M	VAPNP-60C-1-F
	Weight	15.0g	12.0g	47.0g	45.0g
Characteristics of rubber	Heat resistance : 85°C / Shore hardness : 60		Heat resistance : 85°C / Shore hardness : 60		
Applicable stems	Large : VFI-L, or VFIL-H → 3-29,31		Large : VFI-L, or VFIL-H → 3-29,31		



Suction Cups (Vacuum)

Utilize it as per your requirements from a range of products.

Silicone Excellent in durability and heat resistance (250°C).

Fluorine The material exhibits outstanding durability, resistance to heat and chemicals, and is not prone to leaving suction marks, ensuring a prolonged service life.

▶ The lip of bellows cup 2-stage is thin.

Applicable cup size	φ 2mm	φ 4mm	φ 6mm	φ 8mm	φ 10mm	φ 15mm	
Suction Cups (Vacuum)							
Drawing							
Silicone (transparent white)	Order code No.	042095	042096	042038	042039	042040	042041
	TYPE	EPJG-2-S	EPJG-4-S	EPJG-6-S	EPJG-8-S	EPJG-10-S	EPJG-15-S
	Weight	0.1g	0.1g	0.15g	0.25g	0.45g	1.0g
Fluorine (black)	Order code No.	042097	042098	042099	042100	—	—
	TYPE	EPJG-2-F-RA	EPJG-4-F-RA	EPJG-6-F-RA	EPJG-8-F-RA	—	—
	Weight	0.1g	0.1g	0.2g	0.3g	—	—
Applicable head							
Drawing							
Order code No.	042111		042112				
TYPE	ETN-PS-2A-M5		ETN-PS-10-M5				
Weight	0.5g		0.8g				
Applicable stems	VFILB2-SSH, SH series (remove the attach head and use) ▶ 3-30						

Quick Chuck Change

Quick Chuck Change Manual

Quick Chuck Change Manual (OM Type)

Tool Changer

Automated Hand Exchange System

Grip

Mini Cylinder

Accessories for Mini Cylinder

Container Cylinders

Accessories for Container Cylinder

Grippers

Rubber Material / Grip Pad

Suction

Suction Cups

Suction Stems

Pad in Pad

Vacuum Gripper

Air Ejector / Filter / Check Valve

Ultra Small Part Take Out

Vacuum Generator Unit

Cut

Air Nipper (Small-Medium)

Air Nipper (Large)

Frame / Module

Jungle Gym

Let's Joint

Rectangular Tube

Base Aluminum Material

Sliding Chuck

Pneumatic Components / Sensors

Pneumatic Components

Sensors / Multi AND Board

PCIO Communication Unit

Lightweight Parts Series

Frame / Section / Resin Cylinders / Pads / Resin Manifolds

By Industry

Logistics-Palletizing/Sheet Metal-Stamping-Metal Fabrication

Assembling Tools

Tool / Jig

Information













Various Products Information

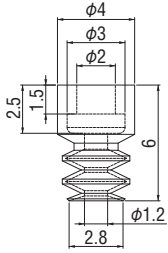
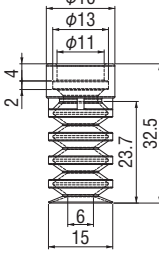
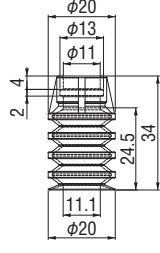
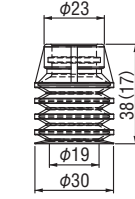
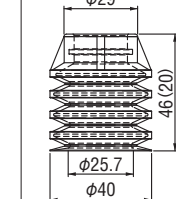
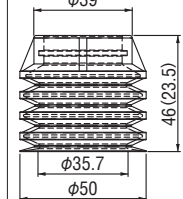

Suction Cups (Multistage Bellows)

Utilize it as per your requirements from a range of products.

► The cushion is of exceptional quality and is well-suited for workpieces with irregular surfaces.

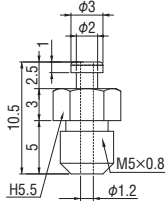
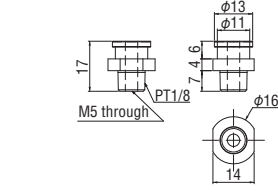
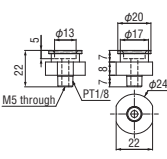
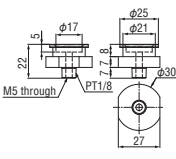
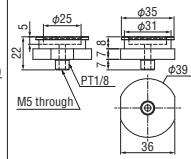
Applicable cup size	φ 3mm	φ 15mm	φ 20mm	φ 30mm	φ 40mm	φ 50mm
Suction Cups (Multistage Bellows)						
Drawing						
Order code No.	042101	042102	042103	042071	042072	042073
TYPE	EPCG-3-S	EPLG-15-S5	EPLG-20-S5	EPLG-30-S5	EPLG-40-S5	EPLG-50-S5
Weight	0.1g	1.6g	20.8g	6.9g	15.7g	20.8g
Applicable head						
Drawing						
Order code No.	042111	211114	211115	211116	211117	
TYPE	ETN-PS-2A-M5	VFILA-PHA-1/8	VFILA-PHB-1/8	VFILA-PHC-1/8	VFILA-PHD-1/8	
Weight	0.5g	4.0g	13.0g	18.0g	34.0g	
Applicable stems	VFILB-SSH → 3-30					VFILB-1/8, VFI-L, VFI-H → 3-29,31



Suction Cups (Pouches)

Use as your situation.

► The soft-bodied, bag-shaped workpiece is transported through the subsequent performance and gripping force.

Star-shaped Type

Applicable cup size	φ24mm (equivalent to φ20mm)	φ40mm (equivalent to φ34mm)	φ56mm (equivalent to φ48mm)
Suction Cups (Pouches)			
Drawing			
Order code No.	042108	042109	042110
TYPE	EPMG-24S-S4	EPMG-40S-S4	EPMG-56S-S4
Weight	2.5g	5.6g	20.3g
Applicable stems	① VFILA-PHA-1/8	② VFILA-PHB-1/8	③ VFILA-PHC-1/8

* The applicable suction head is necessary for using the suction cups.

Star-shaped Bellows Type

Applicable cup size	φ24mm (equivalent to φ20mm)	φ40mm (equivalent to φ34mm)	φ56mm (equivalent to φ48mm)
Suction Cups (Pouches)			
Drawing			
Order code No.	042074	042075	042107
TYPE	EPMG-24L-S4	EPMG-40L-S4	EPMG-56L-S4
Weight	5.0g	10.0g	11.1g
Applicable stems	① VFILA-PHA-1/8	② VFILA-PHB-1/8	③ VFILA-PHC-1/8

* The applicable suction head is necessary for using the suction cups.

Round flat type

Applicable cup size	φ18mm	φ25mm	φ35mm
Suction Cups (Pouches)			
Drawing			
Order code No.	042104	042105	042106
TYPE	EPNG-132B-S4	EPNG-133B-S4	EPNG-134B-S4
Weight	0.5g	2.8g	3.3g
Applicable stems	① VFILA-PHA-1/8		

* The applicable suction head is necessary for using the suction cups.

Suction head for star-shaped and round pouch cups

Outside Stem	①	②	③
Drawing			
Order code No.	211114	211115	211116
TYPE	VFILA-PHA-1/8	VFILA-PHB-1/8	VFILA-PHC-1/8
Weight	4.0g	13.0g	18.0g
Applicable stems	VFILB-1/8, VFI-L, VFIL-H → 3-29,31		

Star-shaped lip shapes could freely follow the soft and bag-shaped work piece.



Special lip structure enables tight suction.

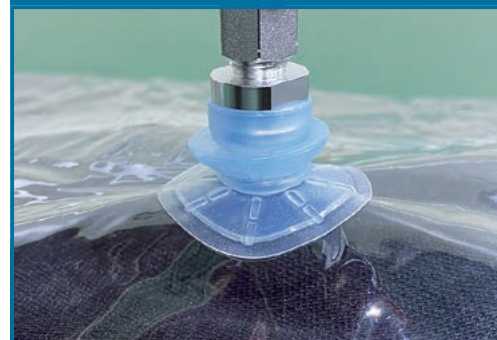

Quick Chuck Change

Quick Chuck Change Manual

Quick Chuck Change Manual (OM Type)

Tool Changer

Automated Hand Exchange System

Grip

Mini Cylinder

Accessories for Mini Cylinder

Container Cylinders

Accessories for Container Cylinder

Grippers

Rubber Material / Grip Pad

Suction

Suction Cups

Suction Stems

Pad in Pad

Vacuum Gripper

Air Ejector / Filter / Check Valve

Ultra Small Part Take Out

Vacuum Generator Unit

Chuck

Air Nipper (Small-Medium)

Air Nipper (Large)

Frame / Module

Jungle Gym

Let's Joint

Rectangular Tube

Base Aluminum Material

Sliding Chuck

Pneumatic Components / Sensors

Pneumatic Components

Sensors / Multi AND Board

PCIO Communication Unit

Lightweight Parts Series

Frame / Suction / Resin Cylinders / Pads / Resin Manifolds

By Industry

Logistics-Palletizing / Sheet Metal-Stamping-Metal Fabrication

Assembling Tools

Tool / Jig

Information







Various Products Information



Non-Contact Suction Pad

Please choose based on the 3 types of lifting forces.

- ▶ It can transfer the work piece of different shapes with one gripper (wood, resin, cardboard, etc.).
- ▶ The absence of contact with the workpiece ensures that it is transported without any suction marks or damage

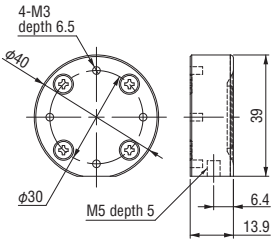
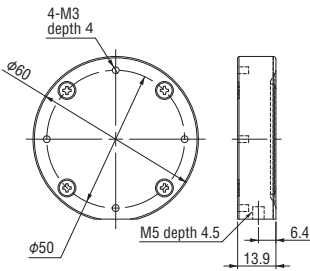
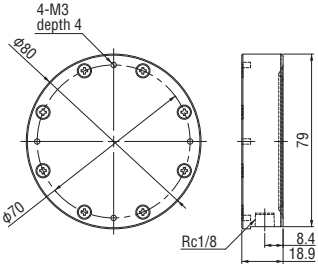
Applicable cup size	φ 40mm	φ 60mm	φ 80mm
Non-Contact Suction Pad	 	 	 
Drawing			
Order code No.	042113	042114	042115
TYPE	ECOPS-40Y	ECOPS-60Y	ECOPS-80Y
Weight	26g	66g	147g

Specification

TYPE	Fluid used	Piping connection diameter	Pressure range (MPa)	Temperature range (°C)	Lift forces (N)	Air consumption (L/min (ANR))	Weight (g)
ECOPS-40Y	Air (Non corrosive and incombustible gas)	M5	0.15 ~ 0.5	0 ~ 45 (However, it doesn't freeze.)	8	88	26
ECOPS-60Y					15	105	66
ECOPS-80Y		Rc1/8			34	168	147

Schematic diagram

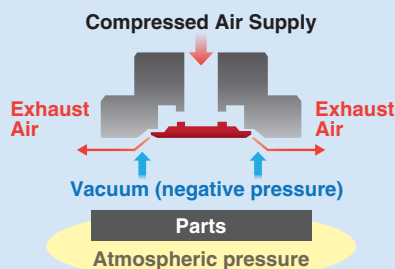

The air is released and sucked, so the inside is clean and it's sanitary to be used even the inside isn't disassembled and cleared up.

Performance graph

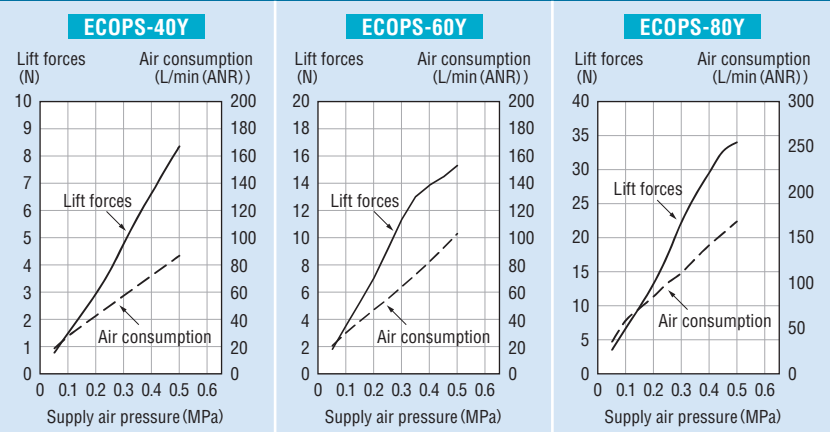



Flat Suction Cups

Flat basic type. Silicone type and a mark-free type are provided.

Silicone Excellent in durability and heat resistance (250°C).

Mark-free It demonstrates exceptional durability and heat resistance up to 140°C, making it resistant to leaving suction marks.

• Can be used by removing suction attach head of the suction stem non-rotate (VFILB,VFILB2).

► It is appropriate for transmitting items that have a flat surface.

Applicable cup size	φ 1.2mm	φ 1.8mm	φ 2mm	φ 3.5mm	φ 5mm	φ 6mm	
Flat Suction Cups							
Drawing							
Silicone (transparent white)	Order code No.	183823	183824	183825	183826	183827	183828
	TYPE	SQN 1 SI-M3 M	SQN 1.5 SI-M3 M	SQN 2 SI-M3 M	SQN 3.5 SI-M3 M	SQN 5 SI-M5 M	SQN 6 SI-M5 M
	Weight	1.0g	1.0g	1.0g	1.0g	1.1g	1.1g
Mark-free (blue)	Order code No.	—	—	—	—	183797	183798
	TYPE	—	—	—	—	SQN 5 HT1-M5 M	SQN 6 HT1-M5 M
	Weight	—	—	—	—	1.1g	1.1g
Applicable stems	Micro : VFILB-M, MSH → 3-23,30				Non-rotate for mini / small or VFILB/VFILBR → 3-30,31		

Applicable cup size	φ 8mm	φ 10mm	φ 15mm	φ 20mm	
Flat Suction Cups					
Drawing					
Silicone (transparent white)	Order code No.	183829	183830	183831	183832
	TYPE	SQN 8 SI-M5 M	SQN 10 SI-M5 M	SQN 15 SI-M5 M	SQN 20 SI-M5 M
	Weight	1.2g	1.3g	4.5g	5.6g
Mark-free (blue)	Order code No.	183799	183800	183801	183802
	TYPE	SQN 8 HT1-M5 M	SQN 10 HT1-M5 M	SQN 15 HT1-M5 M	SQN 20 HT1-M5 M
	Weight	1.2g	1.3g	4.5g	5.6g
Applicable stems	Non-rotate for mini / small or VFILB/VFILBR → 3-30,31				

Quick Chuck Change

Quick Chuck Change Manual

Quick Chuck Change Manual (OM Type)

Tool Changer

Automated Hand Exchange System

Grip

Mini Cylinder

Accessories for Mini Cylinder

Container Cylinders

Accessories for Container Cylinder

Grippers

Rubber Material / Grip Pad

Suction

Suction Cups

Suction Stems

Pad in Pad

Vacuum Gripper

Air Ejector / Filter / Check Valve

Ultra Small Part Take Out

Vacuum Generator Unit

Chuck

Air Nipper (Small-Medium)

Air Nipper (Large)

Frame / Module

Jungle Gym

Let's Joint

Rectangular Tube

Base Aluminum Material

Sliding Chuck

Pneumatic Components / Sensors

Pneumatic Components

Sensors / Multi AND Board

PCIO Communication Unit

Lightweight Parts Series

Frame / Suction / Resin Cylinders / Pads / Resin Manifolds

By Industry

Logistics-Palletizing / Sheet Metal-Stamping-Metal Fabrication





Assembling Tools



Tool / Jig

Information

Various Products Information

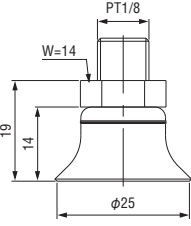
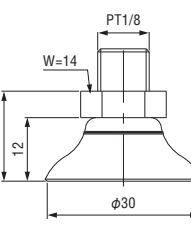
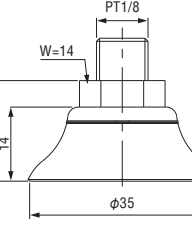
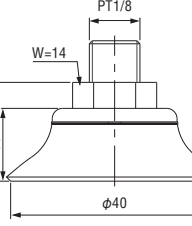
Flat Suction Cups

Applicable cup size	φ 25mm	φ 30mm	φ 35mm	φ 40mm	
Flat Suction Cups					
Drawing					
Silicone (transparent white)	Order code No.	183833	183834	183835	183836
	TYPE	SNQ 25 SI-PT1/8 M	SNQ 30 SI-PT1/8 M	SNQ 35 SI-PT1/8 M	SNQ 40 SI-PT1/8 M
	Weight	7.2g	7.9g	10.6g	12.2g
Mark-free (blue)	Order code No.	183803	183804	183805	183806
	TYPE	SNQ 25 HT1-PT1/8 M	SNQ 30 HT1-PT1/8 M	SNQ 35 HT1-PT1/8 M	SNQ 40 HT1-PT1/8 M
	Weight	7.2g	7.9g	10.6g	12.2g
Applicable stems	Non-rotate for small or VFILB-1/8, large VFI-L, VFIL-H → 3-29,31				

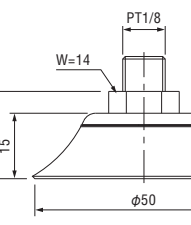
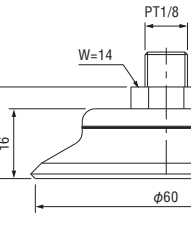
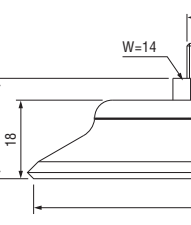
Applicable cup size	φ 50mm	φ 60mm	φ 80mm	
Flat Suction Cups				
Drawing				
Silicone (transparent white)	Order code No.	183837	183838	183839
	TYPE	SNQ 50 SI-PT1/8 M	SNQ 60 SI-PT1/8 M	SNQ 80 SI-PT1/8 M
	Weight	15.3g	34.2g	62.5g
Mark-free (blue)	Order code No.	183807	183808	183809
	TYPE	SNQ 50 HT1-PT1/8 M	SNQ 60 HT1-PT1/8 M	SNQ 80 HT1-PT1/8 M
	Weight	15.3g	34.2g	62.5g
Applicable stems	Non-rotate for small or VFILB-1/8, large VFI-L, VFIL-H → 3-29,31			



Bellows Type Suction Cups 1.5-stage

The bellows cups, characterized by their significant buffering effect, are ideally suited for transporting uneven workpieces.







Silicone





Excellent in durability and heat resistance (250°C).

Mark-free

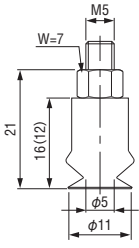
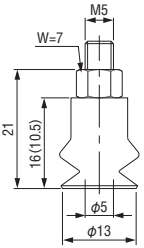
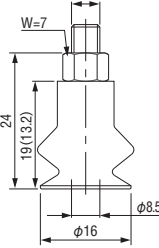
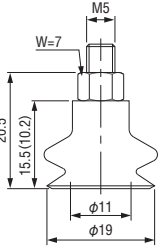
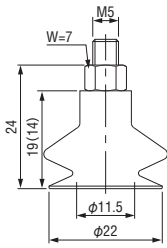
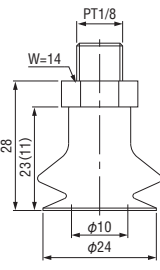
It demonstrates exceptional durability and heat resistance up to 140°C, making it resistant to leaving suction marks.

- The suction attachment can be detached from the non-rotating suction stem (VFILB, VFILB2) for use.

Applicable cup size	φ 11mm	φ 13mm	φ 16mm	φ 19mm	φ 22mm	φ 24mm	
Bellows type Suction Cups 1.5-stage							
Drawing							
* The value in () indicates the dimension with suction.							
Silicone (transparent white)	Order code No.	183874	183875	183876	183877	183878	183994
	TYPE	SFSGA 11 SI-M5 M	SFSGA 14 SI-M5 M	SFSGA 16 SI-M5 M	SFSGA 20 SI-M5 M	SFSGA 22 SI-M5 M	SFSGA 25 SI-PT1/8 M
	Weight	2.0g	2.1g	2.3g	2.7g	3.1g	6.4g
Mark-free (blue)	Order code No.	183857	183858	183859	183860	183861	183993
	TYPE	SFSGA 11 HT1-M5 M	SFSGA 14 HT1-M5 M	SFSGA 16 HT1-M5 M	SFSGA 20 HT1-M5 M	SFSGA 22 HT1-M5 M	SFSGA 25 HT1-PT1/8 M
	Weight	2.0g	2.1g	2.3g	2.7g	3.1g	6.4g
Applicable stems	Non-rotate for mini/small or VFILB/VFILBR → 3-30,31					Non-rotate for small or VFILB-1/8, large VFI-L, VFIL-H → 3-29,31	

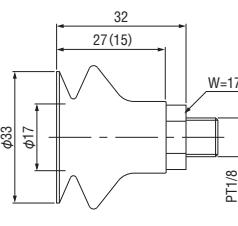
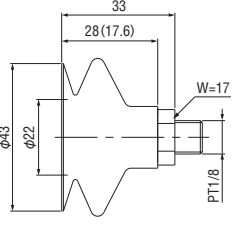
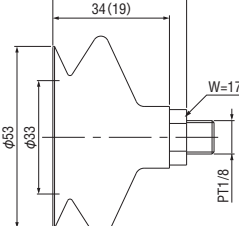
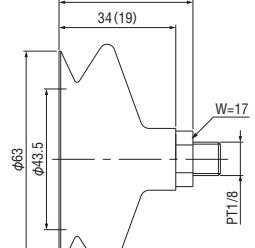
Applicable cup size	φ 33mm	φ 43mm	φ 53mm	φ 63mm	
Bellows type Suction Cups 1.5-stage					
Drawing					
* The value in () indicates the dimension with suction.					
Silicone (transparent white)	Order code No.	183879	183880	183881	183882
	TYPE	SFSGA 33 SI-PT1/8 M	SFSGA 43 SI-PT1/8 M	SFSGA 53 SI-PT1/8 M	SFSGA 63 SI-PT1/8 M
	Weight	15.0g	18.0g	26.0g	33.0g
Mark-free (blue)	Order code No.	183862	183863	183864	—
	TYPE	SFSGA 33 HT1-PT1/8 M	SFSGA 43 HT1-PT1/8 M	SFSGA 53 HT1-PT1/8 M	—
	Weight	15.0g	18.0g	26.0g	—
Applicable stems	Non-rotate for small or VFILB-1/8, large VFI-L, VFIL-H → 3-29,31				

Quick Chuck Change

Quick Chuck Change Manual

Quick Chuck Change Manual (OM Type)

Tool Changer

Automated Hand Exchange System

Grip

Mini Cylinder

Accessories for Mini Cylinder

Container Cylinders

Accessories for Container Cylinder

Grippers

Rubber Material / Grip Pad

Suction

Suction Cups

Suction Stems

Pad in Pad

Vacuum Gripper

Air Ejector / Filter / Check Valve

Ultra Small Part Take Out

Vacuum Generator Unit

Cut

Air Nipper (Small-Medium)

Air Nipper (Large)

Frame / Module

Jungle Gym

Let's Joint

Rectangular Tube

Base Aluminum Material

Sliding Chuck

Pneumatic Components / Sensors

Pneumatic Components

Sensors / Multi AND Board

PCIO Communication Unit

Lightweight Parts Series

Frame / Suction / Resin Cylinders / Pads / Resin Manifolds

By Industry

Logistics - Palletizing / Sheet Metal - Stamping - Metal Fabrication

Assembling Tools

Tool / Jig

Information

Various Products Information



Bellows Type Suction Cups 2.5-stage

Bellows cups, characterized by their significant buffering effect, are ideally suited for transporting workpieces that are angled or uneven.

Silicone

Excellent in durability and heat resistance (250°C).

Mark-free

It demonstrates exceptional durability and heat resistance up to 140°C, making it resistant to leaving suction marks.

• Can be used by removing suction attach head of the suction stem non-rotate (VFILB,VFILB2).

Applicable cup size	φ 5.5mm	φ 6.5mm	φ 9.3mm	φ 12.7mm	φ 15mm	φ 18.5mm	
Bellows type Suction Cups 2.5-stage							
Drawing							
* The value in () indicates the dimension with suction.							
Silicone (transparent white)	Order code No.	183909	183910	183911	183912	183913	183914
	TYPE	SFSG 5 SI-M5 M	SFSG 7 SI-M5 M	SFSG 9 SI-M5 M	SFSG 12 SI-M5 M	SFSG 14 SI-M5 M	SFSG 18 SI-M5 M
	Weight	1.5g	1.6g	1.8g	2.2g	2.6g	2.9g
Mark-free (blue)	Order code No.	—	—	183893	183894	183895	183896
	TYPE	—	—	SFSG 9 HT1-M5 M	SFSG 12 HT1-M5 M	SFSG 14 HT1-M5 M	SFSG 18 HT1-M5 M
	Weight	—	—	1.8g	2.2g	2.6g	2.9g
Applicable stems	Non-rotate for mini/small or VFILB/VFILBR → 3-30,31						

Applicable cup size	φ 20mm	φ 24.7mm	φ 32.6mm	φ 43.5mm	φ 52.5mm	φ 62.2mm	
Bellows type Suction Cups 2.5-stage							
Drawing							
* The value in () indicates the dimension with suction.							
Silicone (transparent white)	Order code No.	183915	183916	183917	183918	183919	183920
	TYPE	SFSG 20 SI-M5 M	SFSG 25 SI-PT1/8 M	SFSG 32 SI-PT1/8 M	SFSG 42 SI-PT1/8 M	SFSG 52 SI-PT1/8 M	SFSG 62 SI-PT1/8 M
	Weight	3.3g	8.0g	16.0g	26.0g	31.0g	59.0g
Mark-free (blue)	Order code No.	183897	183898	183899	183900	—	—
	TYPE	SFSG 20 HT1-M5 M	SFSG 25 HT1-PT1/8 M	SFSG 32 HT1-PT1/8 M	SFSG 42 HT1-PT1/8 M	—	—
	Weight	3.3g	8.0g	16.0g	26.0g	—	—
Applicable stems	Non-rotate for mini/small or VFILB, VFILBR → 3-30,31		Non-rotate for small or VFILB-1/8, large VFI-L, VFIL-H → 3-29,31		Large, VFI-L, or VFIL-H → 3-29,31		



Oval Cups

Oval Cups are ideal for transporting elongated and slender workpieces.

Silicone

Excellent in durability and heat resistance (250°C).

Mark-free

It demonstrates exceptional durability and heat resistance up to 140°C, making it resistant to leaving suction marks.

- Can be used by removing suction attach head of the suction stem non-rotate (VFILB,VFILB2).

Applicable cup size	2×4mm	3.5×7mm	5×15mm	6×18mm
Oval cups				
Drawing				
Silicone (transparent white)	Order code No.	187222	187223	—
	TYPE	SSGON-4 * 2-SI-65-M3-M	SSGON-7 * 3.5-SI-65-M3-M	—
	Weight	2.0g	2.0g	—
Mark-free (blue)	Order code No.	183932	183933	183935
	TYPE	SSGON 2 * 4 HT1-M3 M	SSGON 3.5 * 7 HT1-M3 M	SSGON 6 * 18 HT1-M5 M
	Weight	2.0g	2.0g	3.7g
Applicable stems	Micro or VFILB-M,MSH → 3-23,30		Non-rotate for mini/small or VFILB/VFILBR → 3-30,31	

Applicable cup size	8×24mm	10×30mm	15×45mm
Oval cups			
Drawing			
Silicone (transparent white)	Order code No.	—	187225
	TYPE	—	SSGON-30 * 10-SI-65-PT1/8-M
	Weight	—	6.8g
Mark-free (blue)	Order code No.	183936	183937
	TYPE	SSGON 8 * 24 HT1-PT1/8 M	SSGON 10 * 30 HT1-PT1/8 M
	Weight	6.7g	6.8g
Applicable stems	Non-rotate for small or VFILB-1/8, large VFI-L, VFIL-H → 3-29,31		

Quick Chuck Change

Quick Chuck Change Manual

Quick Chuck Change Manual (OM Type)

Tool Changer

Automated Hand Exchange System

Grip

Mini Cylinder

Accessories for Mini Cylinder

Container Cylinders

Accessories for Container Cylinder

Grippers

Rubber Material / Grip Pad

Suction

Suction Cups

Suction Stems

Pad in Pad

Vacuum Gripper

Air Ejector / Filter / Check Valve

Ultra Small Part Take Out

Vacuum Generator Unit

Cut

Air Nipper (Small-Medium)

Air Nipper (Large)

Frame / Module

Jungle Gym

Let's Joint

Rectangular Tube

Base Aluminum Material

Sliding Chuck

Pneumatic Components / Sensors

Pneumatic Components

Sensors / Multi AND Board

PCIO Communication Unit

Lightweight Parts Series

Frame / Section / Resin Cylinders / Pads / Resin Manifolds

By Industry

Logistics - Palletizing / Sheet Metal - Stamping - Metal Fabrication

Assembling Tools

Tool / Jig

Information





Various Products Information



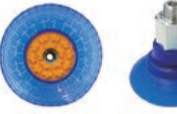

Sheet Metal Suction Cups

Best for high-speed conveyance of oil-filmed sheet metal.

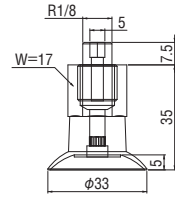
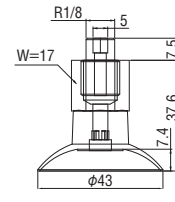
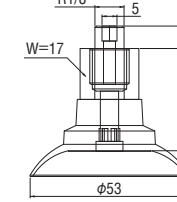
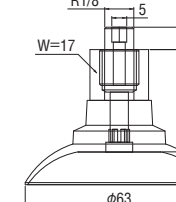
► Strong holding power in the horizontal direction. Utilize the superior suction capability provided by the groove on the suction surface.

Applicable cup size	φ 33mm	φ 43mm	φ 53mm	φ 63mm
Suction Cups for sheet metal w/ screw				
Drawing				
Order code No.	187562	187563	187564	187565
TYPE	SSAXM-30-ED85-PT1/8AGJNT	SSAXM-40-ED85-PT1/8AGJNT	SSAXM-50-ED85-PT1/8AGJNT	SSAXM-60-ED85-PT1/8AGJNT
Holding force* ¹	39N	69N	109N	154N
Horizontal power (with oil)* ²	41N	71N	110N	155N
Weight	23.2g	23.7g	36.3g	41.0g
Applicable stems	Non-rotate for small or VFILB-1/8, large VFI-L, VFIL-H → 3-29,31			

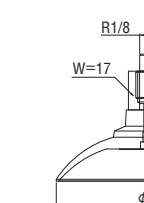
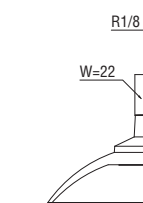
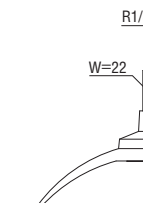
Applicable cup size	φ 83mm	φ 103mm	φ 118mm
Suction Cups for sheet metal w/ screw			
Drawing			
Order code No.	187566	187567	187568
TYPE	SSAXM-80-ED85-PT1/8AGJNT	SSAXM-100-ED85-PT1/8AGJNT	SSAXM-115-ED85-PT1/8AGJNT
Holding force* ¹	270N	412N	549N
Horizontal power (with oil)* ²	269N	414N	584N
Weight	50.5g	89.8g	109.9g
Applicable stems	Non-rotate for small or VFILB-1/8, large VFI-L, VFIL-H → 3-29,31		

*1 Above holding force is calculated with dried workpiece with a smooth surface (vertical direction, vacuum pressure -60 kPa). Safety factor is not included.

*2 Above horizontal force is calculated with dried/oil-filmed workpiece with a smooth surface (vacuum pressure -60 kPa). Actual values may vary depending on the state of the work piece surface. Safety factor is not included.

Upper connector

A seal ring is included to prevent air leakage.

Rubber part

Composed of Elastodur, this material exhibits outstanding flexibility and exceptional resistance to wear.

Underside connector with brake foot

Prevents products from being drawn into the pad or deforming.

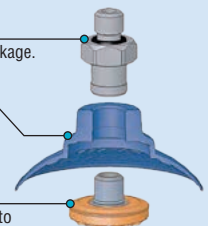



Suction Cups for Exchange

Suction Cups for exchange in 3-15 ~ 3-19.

▶ Suction Cups for Flat Suction Cups.

Page	Order code No.	TYPE	Material	Cup color
3-15	183840	SQ 1 SI	silicone	Cloudy transparent
	183841	SQ 1.5 SI	silicone	Cloudy transparent
	183842	SQ 2 SI	silicone	Cloudy transparent
	183843	SQ 3.5 SI	silicone	Cloudy transparent
	183844	SQ 5 SI	silicone	Cloudy transparent
	183845	SQ 6 SI	silicone	Cloudy transparent
	183846	SQ 8 SI	silicone	Cloudy transparent
	183847	SQ 10 SI	silicone	Cloudy transparent
	183848	SQ 15 SI	silicone	Cloudy transparent
183849	SQ 20 SI	silicone	Cloudy transparent	
3-16	183850	SQ 25 SI	silicone	Cloudy transparent
	183851	SQ 30 SI	silicone	Cloudy transparent
	183852	SQ 35 SI	silicone	Cloudy transparent
	183853	SQ 40 SI	silicone	Cloudy transparent
	183854	SQ 50 SI	silicone	Cloudy transparent
	183855	SQ 60 SI	silicone	Cloudy transparent
	183856	SQ 80 SI	silicone	Cloudy transparent
3-15	183810	SQ 5 HT1	Mark-free	Blue
	183811	SQ 6 HT1	Mark-free	Blue
	183812	SQ 8 HT1	Mark-free	Blue
	183813	SQ 10 HT1	Mark-free	Blue
	183814	SQ 15 HT1	Mark-free	Blue
3-16	183815	SQ 20 HT1	Mark-free	Blue
	183816	SQ 25 HT1	Mark-free	Blue
	183817	SQ 30 HT1	Mark-free	Blue
	183818	SQ 35 HT1	Mark-free	Blue
	183819	SQ 40 HT1	Mark-free	Blue
	183820	SQ 50 HT1	Mark-free	Blue
	183821	SQ 60 HT1	Mark-free	Blue
	183822	SQ 80 HT1	Mark-free	Blue

▶ Suction Cups for flat oval.

Page	Order code No.	TYPE	Material	Cup color
3-19	187227	SSGO-4*2-SI-65	silicone	White
	187228	SSGO-7*3.5-SI-65	silicone	White
	187229	SSGO-15*5-SI-65	silicone	White
	187230	SSGO-30*10-SI-65*	silicone	White
	187231	SSGO-45*15-SI-65*	silicone	White
3-19	183940	SSGO 2*4 HT1	Mark-free	Blue
	183941	SSGO 3.5*7 HT1	Mark-free	Blue
	183942	SSGO 5*15 HT1	Mark-free	Blue
	183943	SSGO 6*18 HT1*	Mark-free	Blue
	183944	SSGO 8*24 HT1*	Mark-free	Blue
	183945	SSGO 10*30 HT1*	Mark-free	Blue
	183946	SSGO 15*45 HT1*	Mark-free	Blue

* Incorporate the stem for securing the cups.

▶ Bellows type Suction Cups 1.5-stage.

Page	Order code No.	TYPE	Material	Cup color
3-17	183883	SFGA 11 SI	silicone	Cloudy transparent
	183884	SFGA 14 SI	silicone	Cloudy transparent
	183885	SFGA 16 SI	silicone	Cloudy transparent
	183886	SFGA 20 SI	silicone	Cloudy transparent
	183887	SFGA 22 SI	silicone	Cloudy transparent
	183888	SFGA 25 SI	silicone	Cloudy transparent
	183889	SFGA 33 SI	silicone	Cloudy transparent
	183890	SFGA 43 SI	silicone	Cloudy transparent
	183891	SFGA 53 SI	silicone	Cloudy transparent
	183892	SFGA 63 SI	silicone	Cloudy transparent
3-17	183865	SFGA 11 HT 1	Mark-free	Blue
	183866	SFGA 14 HT1	Mark-free	Blue
	183867	SFGA 16 HT1	Mark-free	Blue
	183868	SFGA 20 HT1	Mark-free	Blue
	183869	SFGA 22 HT1	Mark-free	Blue
	183870	SFGA 25 HT1	Mark-free	Blue
	183871	SFGA 33 HT1	Mark-free	Blue
	183872	SFGA 43 HT1	Mark-free	Blue
	183873	SFGA 53 HT1	Mark-free	Blue

▶ Bellows type Suction Cups 2.5-stage.

Page	Order code No.	TYPE	Material	Cup color
3-18	183921	SFG 5 SI	silicone	Cloudy transparent
	183922	SFG 7 SI	silicone	Cloudy transparent
	183923	SFG 9 SI	silicone	Cloudy transparent
	183924	SFG 12 SI	silicone	Cloudy transparent
	183925	SFG 14 SI	silicone	Cloudy transparent
	184085	SFG 18 SI	silicone	Cloudy transparent
	183926	SFG 20 SI	silicone	Cloudy transparent
	183927	SFG 25 SI	silicone	Cloudy transparent
	183928	SFG 32 SI	silicone	Cloudy transparent
	183929	SFG 42 SI	silicone	Cloudy transparent
	183930	SFG 52 SI	silicone	Cloudy transparent
	183931	SFG 62 SI	silicone	Cloudy transparent
3-18	183901	SFG 9 HT1	Mark-free	Blue
	183902	SFG 12 HT1	Mark-free	Blue
	183903	SFG 14 HT1	Mark-free	Blue
	183904	SFG 18 HT1	Mark-free	Blue
	183905	SFG 20 HT1	Mark-free	Blue
	183906	SFG 25 HT1	Mark-free	Blue
	183907	SFG 32 HT1	Mark-free	Blue
	183908	SFG 42 HT1	Mark-free	Blue

Quick Chuck Change

Quick Chuck Change Manual

Quick Chuck Change Manual (OM Type)

Tool Changer

Automated Hand Exchange System

Grip

Mini Cylinder

Accessories for Mini Cylinder

Container Cylinders

Accessories for Container Cylinder

Grippers

Rubber Material / Grip Pad

Suction

Suction Cups

Suction Stems

Pad in Pad

Vacuum Gripper

Air Ejector / Filter / Check Valve

Ultra Small Part Take Out

Vacuum Generator Unit

Cut

Air Nipper (Small-Medium)

Air Nipper (Large)

Frame / Module

Jungle Gym

Let's Joint

Rectangular Tube

Base Aluminum Material

Sliding Chuck

Pneumatic Components / Sensors

Pneumatic Components

Sensors / Multi AND Board

PCIO Communication Unit

Lightweight Parts Series

Frame / Suction / Resin Cylinders / Pads / Resin Manifolds

By Industry

Logistics-Palletizing/Sheet Metal-Stamping-Metal Fabrication

Assembling Tools

Tool / Jig

Information

Various Products Information



Please check the performance table on the web site.

Suction stems

Can be selected according to the type of suction cup and allows secure suction.



Micro

3-23



Mini

3-23



Small

3-26



Large

3-29



Mini

3-23



Small

3-26

Resin Suction stems

Weight saving achieved by using plastic for the body.

Suction stems locking mechanism

Non-rotating suction stems. These feature a long stroke, holding unit in position at the stopper cylinder.

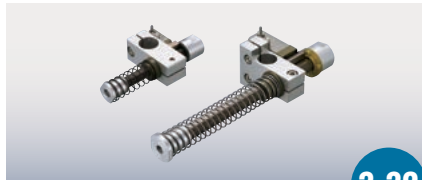

3-32

Suction stems non-rotate

Exchangeable head for suction stem.



Micro

3-30



Mini

3-30



Small

3-30



1/8 For connection

3-31

Suction stems non-rotate

Exchangeable head for suction stem.



Angle adjustment

3-31



Large

3-31

Fixed

Please use with a pad on the tip.



3-36

Suction Stems for Mini Cylinder

Used when suction cup is attached to the end of mini cylinder.



3-36

Adjuster

Height of suction stem can be adjusted.



3-37

Suction stems angle brackets

The angle can be adjusted by attaching a pad to the tip.



3-38

Spring constant value of suction stem

No.	TYPE	Spring constant (N/mm)	spring constant of suction stem (N)	No.	TYPE	Spring constant (N/mm)	spring constant of suction stem (N)
1	VFILB-M/VFILB-M-P8	0.29	2.62	8	VFIL1-SS-30/VFIL2-SS-30-P8/ VFIL2-SS-30-P12	0.12	4.49
2	VFILB2-SSH/VFILB2-SSH-P12/ VFILB2-SH/VFILB2-SH-P12/ VFILB2-SH1/8/VFILB2-SH1/8-P12	0.65	7.76	9	VFIL-S-5A/VFIL1-S-5-P12/ VFIL1-S-5-P20	0.27	2.46
3	VFILB2-SSH-20/VFILB2-SSH-20-P12/ VFILB2-SH-20/VFILB2-SH-20-P12/ VFILB2-SH1/8-20/VFILB2-SH1/ 8-20-P12	0.50	12.10	10	VFIL-S-10A/VFIL1-S-10-P12/ VFIL1-S-10-P20	0.16	2.63
4	VFIL-H	0.80	16.87	11	VFIL-S-20A/VFIL1-S-20-P12/ VFIL1-S-20-P20	0.11	2.81
5	VFIL1-SS-5/VFIL2-SS-5-P8/ VFIL2-SS-5-P12	0.50	3.99	12	VFIL-S-30A/VFIL1-S-30-P12/ VFIL1-S-30-P20	0.08	2.91
6	VFIL1-SS-10/VFIL2-SS-10-P8/ VFIL2-SS-10-P12	0.25	3.99	13	VFI-L-20-M17/VFI-L-20-P20	1.11	28.96
7	VFIL1-SS-20/VFIL2-SS-20-P8/ VFIL2-SS-20-P12	0.17	4.16	14	VFI-L-50-M17/VFI-L-50-P20	0.67	37.43
				15	VFI-L-100-M22	0.19	19.81

* Spring constant. The spring force during in compression is a reference value.



Suction Stems (Micro/Mini)



Direct connection on jungle gym series parts is possible.

Can be selected according to the type of suction cup and allows secure suction.

- The suction cup is sold separately.
- Cup fixing system : embedded

Suction stems (micro)		
Drawing		
Order code No.	210785	210818
TYPE	VFILB-M	VFILB-M-P8
Weight	5g	6g
Piping/Mounting	$\phi 4 / M6 P=0.75$	$\phi 4 / \phi 8$
Applicable cup size	VAPH-4 (6) M \rightarrow 3-4 / VAPH (F) -3C-3 \rightarrow 3-6,10 / $\phi 1.2 \sim 3.5 \rightarrow$ 3-15	



Suction fitting attach head/M3, micro

Order code No.	131316
TYPE	N01891-201

- Weight : 1g
- W/ gasket
- Target: suction stem (micro), suction stem non-rotate (micro)

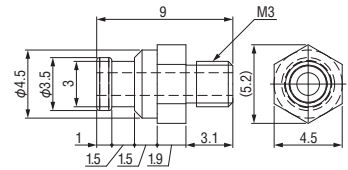

Suction Stems (Mini)			
Drawing (5st)			
Order code No.	211029	211030	211031
TYPE	VFIL1-SS-5	VFIL2-SS-5-P8	VFIL2-SS-5-P12
Weight	14g	9g	13g
Piping/Mounting	$\phi 6 / M10 P=1.0$	$\phi 6 / \phi 8$	$\phi 6 / \phi 12$
Applicable cup size	$\phi 4 \sim 14 \rightarrow$ 3-4,7,8 / TR-1062-1M $\sim 4M \rightarrow$ 3-6 / $\phi 1.2 \sim 3.5 \rightarrow$ 3-15		

Resin Suction Stems (Mini)			
Drawing (5st)			
Order code No.	211109	211105	211144
TYPE	VFILP-SS-5	VFILP-SS-5-P12	VFILPL-SS-5
Weight	9g	4g	4.8g
Piping/Mounting	$\phi 6 / M10 P=1.0$	$\phi 6 / \phi 12$	$\phi 6 / M10 P=1.0$
Applicable cup size	$\phi 4 \sim 14 \rightarrow$ 3-4,7,8 / TR-1062-1M $\sim 4M \rightarrow$ 3-6		

*1 When fixing to the bracket, insert it all the way to the base.

*2 Be careful not to tighten the nut too tightly. (Recommended tightening torque : 0.8 ~ 1.0N · m)

Quick Chuck Change

Quick Chuck Change Manual

Quick Chuck Change Manual (OM Type)

Tool Changer

Automated Hand Exchange System

Grip

Mini Cylinder

Accessories for Mini Cylinder

Container Cylinders

Accessories for Container Cylinder

Grippers

Rubber Material / Grip Pad

Suction

Suction Cups

Suction Stems

Pad in Pad

Vacuum Gripper

Air Ejector / Filter / Check Valve

Ultra Small Part Take Out

Vacuum Generator Unit

Cut

Air Nipper (Small-Medium)

Air Nipper (Large)

Frame / Module

Jungle Gym

Let's Joint

Rectangular Tube

Base Aluminum Material

Sliding Chuck

Pneumatic Components / Sensors

Pneumatic Components

Sensors / Multi AND Board

PCIO Communication Unit

Lightweight Parts Series

Frame / Suction / Resin Cylinders (Pads) / Resin Manifolds

By Industry

Logistics - Palletizing / Sheet Metal - Stamping - Metal Fabrication

Assembling Tools

Tool / Jig

Information

Various Products Information



Suction Stems (Mini)

Can be selected according to the type of suction cup and allows secure suction.

● The suction cup is sold separately. ● Cup fixing system : embedded

Suction Stems (Mini)			
Drawing (10st)			
Order code No.	211032	211033	211034
TYPE	VFIL1-SS-10	VFIL2-SS-10-P8	VFIL2-SS-10-P12
Weight	15g	9g	14g
Piping/Mounting	φ6 / M10 P=1.0	φ6 / φ8	φ6 / φ12
Applicable cup size	φ4 ~ 14 → 3-4,7,8 / TR-1062-1M ~ 4M → 3-6 / φ1.2 ~ 3.5 → 3-15		

Resin Suction Stems (Mini)			
Drawing (10st)			
Order code No.	211110	211106	211145
TYPE	VFILP-SS-10	VFILP-SS-10-P12	VFILPL-SS-10
Weight	9g	4g	5.1g
Piping/Mounting	φ6 / M10 P=1.0	φ6 / φ12	φ6 / M10 P=1.0
Applicable cup size	φ4 ~ 14 → 3-4,7,8 / TR-1062-1M ~ 4M → 3-6		

Suction Stems (Mini)			
Drawing (20st)			
Order code No.	211035	211036	211037
TYPE	VFIL1-SS-20	VFIL2-SS-20-P8	VFIL2-SS-20-P12
Weight	15g	10g	14g
Piping/Mounting	φ6 / M10 P=1.0	φ6 / φ8	φ6 / φ12
Applicable cup size	φ4 ~ 14 → 3-4,7,8 / TR-1062-1M ~ 4M → 3-6 / φ1.2 ~ 3.5 → 3-15		

*1 When fixing to the bracket, insert it all the way to the base.
 *2 Be careful not to tighten the nut too tightly. (Recommended tightening torque : 0.8 ~ 1.0N · m)

Suction ● Suction Stems



Direct connection on jungle gym series parts is possible.

● The suction cup is sold separately. ● Cup fixing system : embedded

Resin Suction Stems (Mini)			* 1	* 2
Drawing (20st)				
Order code No.	211111	211107		211146
TYPE	VFILP-SS-20	VFILP-SS-20-P12		VFILPL-SS-20
Weight	10g	6g		5.85g
Piping/Mounting	φ6 / M10 P=1.0	φ6 / φ12		φ6 / M10 P=1.0
Applicable cup size	φ4 ~ 14 ⇒ 3-4.7.8 / TR-1062-1M ~ 4M ⇒ 3-6			

Suction Stems (Mini)			
Drawing (30st)			
Order code No.	211038	211039	211040
TYPE	VFIL1-SS-30	VFIL2-SS-30-P8	VFIL2-SS-30-P12
Weight	17g	11g	15g
Piping/Mounting	φ6 / M10 P=1.0	φ6 / φ8	φ6 / φ12
Applicable cup size	φ4 ~ 14 ⇒ 3-4.7.8 / TR-1062-1M ~ 4M ⇒ 3-6 / φ1.2 ~ 3.5 ⇒ 3-15		

Resin Suction Stems (Mini)			* 1	* 2
Drawing (30st)				
Order code No.	211112	211108		211147
TYPE	VFILP-SS-30	VFILP-SS-30-P12		VFILPL-SS-30
Weight	11g	7g		6.4g
Piping/Mounting	φ6 / M10 P=1.0	φ6 / φ12		φ6 / M10 P=1.0
Applicable cup size	φ4 ~ 14 ⇒ 3-4.7.8 / TR-1062-1M ~ 4M ⇒ 3-6			

*1 When fixing to the bracket, insert it all the way to the base.
*2 Be careful not to tighten the nut too tightly. (Recommended tightening torque : 0.8 ~ 1.0N · m)

Quick Chuck Change

Quick Chuck Change Manual

Quick Chuck Change Manual (OM Type)

Tool Changer

Automated Hand Exchange System

Grip

Mini Cylinder

Accessories for Mini Cylinder

Container Cylinders

Accessories for Container Cylinder

Grippers

Rubber Material / Grip Pad

Suction

Suction Cups

Suction Stems

Pad in Pad

Vacuum Gripper

Air Ejector / Filter / Check Valve

Ultra Small Part Take Out

Vacuum Generator Unit

Cut

Air Nipper (Small-Medium)

Air Nipper (Large)

Frame / Module

Jungle Gym

Let's Joint

Rectangular Tube

Base Aluminum Material

Sliding Chuck

Pneumatic Components / Sensors

Pneumatic Components

Sensors / Multi AND Board

PCIO Communication Unit

Lightweight Parts Series

Frame / Suction / Resin Cylinders / Pads / Resin Manifolds

By Industry

Logistics-Palletizing / Sheet Metal-Stamping-Metal Fabrication

Assembling Tools

Tool / Jig

Information

Various Products Information



Suction Stems (Small)

Can be selected according to the type of suction cup and allows secure suction.

● The suction cup is sold separately. ● Cup fixing system : embedded

Suction stems (small)			
Drawing (5st)			
Order code No.	210974	211006	211007
TYPE	VFIL-S-5A	VFIL-S-5-P12	VFIL-S-5-P20
Weight	20g	15g	22g
Piping/Mounting	φ6 / M12 P=1.0	φ6 / φ12	φ6 / φ20
Applicable cup size	φ15 ~ 45 → 3-4,5,6,7,8 / TR-1062-1 ~ 4 → 3-6 / SQN type is φ5 ~ 22 → 3-17,18		

Resin Suction Stems (small)			
Drawing (5st)			
Order code No.	211097	211092	211148
TYPE	VFILP-S-5	VFILP-S-5-P12	VFILP-S-5
Weight	16g	7g	8.35g
Piping/Mounting	φ6 / M12 P=1.0	φ6 / φ12	φ6 / M12 P=1.0
Applicable cup size	φ15 ~ 45 → 3-4,5,6,7,8 / TR-1062-1 ~ 4 → 3-6		

Suction stems (small)			
Drawing (10st)			
Order code No.	210975	211008	211009
TYPE	VFIL-S-10A	VFIL-S-10-P12	VFIL-S-10-P20
Weight	21g	16g	29g
Piping/Mounting	φ6 / M12 P=1.0	φ6 / φ12	φ6 / φ20
Applicable cup size	φ15 ~ 45 → 3-4,5,6,7,8 / TR-1062-1 ~ 4 → 3-6 / SQN type is φ5 ~ 22 → 3-17,18		



*1 When fixing to the bracket, insert it all the way to the base.
 *2 Be careful not to tighten the nut too tightly. (Recommended tightening torque : 0.8 ~ 1.0N · m)



Suction ● Suction Stems



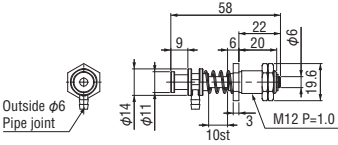
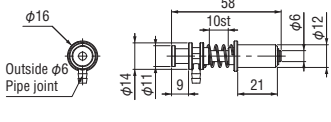
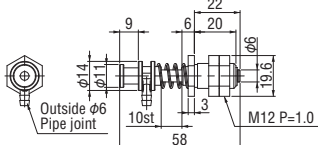

Direct connection on jungle gym series parts is possible.

● The suction cup is sold separately. ● Cup fixing system : embedded

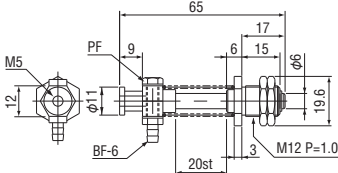
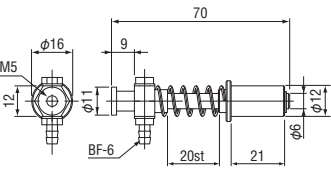
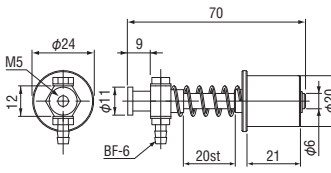
Resin Suction Stems (small)			* 1 NEW		* 2
Drawing (10st)					
Order code No.	211098	211093		211149	
TYPE	VFILP-S-10	VFILP-S-10-P12		VFILPL-S-10	
Weight	16g	7g		8.85g	
Piping/Mounting	φ6 / M12 P=1.0	φ6 / φ12		φ6 / M12 P=1.0	
Applicable cup size	φ15 ~ 45 → 3-4,5,6,7,8 / TR-1062-1 ~ 4 → 3-6				

Suction stems (small)					
Drawing (20st)					
Order code No.	210976	211010		211011	
TYPE	VFIL-S-20A	VFIL1-S-20-P12		VFIL1-S-20-P20	
Weight	22g	18g		31g	
Piping/Mounting	φ6 / M12 P=1.0	φ6 / φ12		φ6 / φ20	
Applicable cup size	φ15 ~ 45 → 3-4,5,6,7,8 / TR-1062-1 ~ 4 → 3-6 / SQN type is φ5 ~ 22 → 3-17,18				

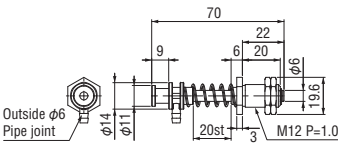
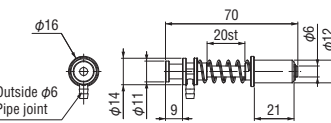
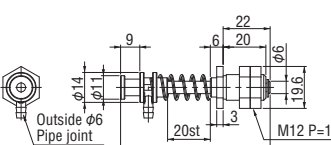
Resin Suction Stems (small)			* 1 NEW		* 2
Drawing (20st)					
Order code No.	211099	211094		211150	
TYPE	VFILP-S-20	VFILP-S-20-P12		VFILPL-S-20	
Weight	17g	8g		9.7g	
Piping/Mounting	φ6 / M12 P=1.0	φ6 / φ12		φ6 / M12 P=1.0	
Applicable cup size	φ15 ~ 45 → 3-4,5,6,7,8 / TR-1062-1 ~ 4 → 3-6				

*1 When fixing to the bracket, insert it all the way to the base.
*2 Be careful not to tighten the nut too tightly. (Recommended tightening torque : 0.8 ~ 1.0N · m)

Quick Chuck Change

Quick Chuck Change Manual

Quick Chuck Change Manual (OM Type)

Tool Changer

Automated Hand Exchange System

Grip

Mini Cylinder

Accessories for Mini Cylinder

Container Cylinders

Accessories for Container Cylinder

Grippers

Rubber Material / Grip Pad

Suction

Suction Cups

Suction Stems

Pad in Pad

Vacuum Gripper

Air Ejector / Filter / Check Valve

Ultra Small Part Take Out

Vacuum Generator Unit

Cut

Air Nipper (Small-Medium)

Air Nipper (Large)

Frame / Module

Jungle Gym

Let's Joint

Rectangular Tube

Base Aluminum Material

Sliding Chuck

Pneumatic Components / Sensors

Pneumatic Components

Sensors / Multi AND Board

PCIO Communication Unit

Lightweight Parts Series

Frame / Suction / Resin Cylinders / Pads / Resin Manifolds

By Industry

Logistics-Palletizing/Sheet Metal-Stamping-Metal Fabrication

Assembling Tools

Tool / Jig

Information

Various Products Information

Suction Stems (Small)/Taper Washer



Direct connection on jungle gym series parts is possible.

● The suction cup is sold separately. ● Cup fixing system : embedded

Suction stems (small)			
Drawing (30st)			
Order code No.	210977	211012	211013
TYPE	VFIL-S-30A	VFIL1-S-30-P12	VFIL1-S-30-P20
Weight	24g	19g	32g
Piping/Mounting	φ6 / M12 P=1.0	φ6 / φ12	φ6 / φ20
Applicable cup size	φ15 ~ 45 ⇒ 3-4.5.6.7.8 / TR-1062-1 ~ 4 ⇒ 3-6 / SQN type is φ5 ~ 22 ⇒ 3-17.18		

Resin Suction Stems (small)			
Drawing (30st)			
Order code No.	211100	211095	211151
TYPE	VFILP-S-30	VFILP-S-30-P12	VFILPL-S-30
Weight	18g	9g	10.5g
Piping/Mounting	φ6 / M12 P=1.0	φ6 / φ12	φ6 / M12 P=1.0
Applicable cup size	φ15 ~ 45 ⇒ 3-4.5.6.7.8 / TR-1062-1 ~ 4 ⇒ 3-6		

*1 When fixing to the bracket, insert it all the way to the base.

*2 Be careful not to tighten the nut too tightly. (Recommended tightening torque : 0.8 ~ 1.0N · m)

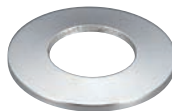

Taper washer (mini)

Order code No.	371362
TYPE	φ10 taper washer for VFIL-SS

- Use when fixing a suction stems to the plate.
- Target: suction stems(mini), suction stems non-rotate(mini, small)

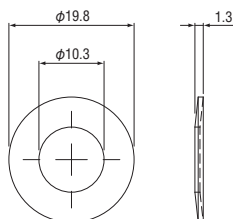

Taper washer (small)

Order code No.	370244
TYPE	φ12 taper washer for VFIL-S

- Use when fixing a suction stems to the plate.
- Target: suction stems (small)

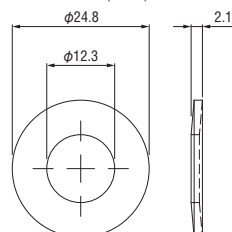



Suction Stems (Large)



Direct connection on jungle gym series parts is possible.

Can be selected according to the type of suction cup and allows secure suction.

- The suction cup is sold separately. • Cup fixing system: embedded, screw mount
- The attach head of the suction metal fixture (large) is optionally available.

Suction stems (large)				
Drawing				
Order code No.	210886	210887	210888	210889
TYPE	VFI-L-20-P20	VFI-L-50-P20	VFI-L-20-M17	VFI-L-50-M17
Weight	45g	55g	50g	60g
Piping/Mounting	φ6 (RBF → 6-5 and BF-6 → 6-5) are necessary for piping) / φ20			
Applicable cup size	φ15 ~ 118 → 3-5,6,7,8,10,11,12,13,16,17,18,19,20			

Suction stems (large)	
	* Use within 100mm stroke.
Drawing	
Order code No.	210917
TYPE	VFI-L-100-M22
Weight	220g
Piping/Mounting	φ6 / M22 P=1.5
Applicable cup size	φ24 ~ 70

Suction stems attachment head, embedded type, small

Order code No.	230066
TYPE	XL0037-106

- Weight : 5g
- Target: suction stems (large), suction stems non-rotate (1/8 series), suction stems non-rotate (large)

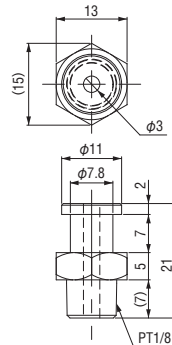

Suction stems attachment head, screw attach type

Order code No.	230067
TYPE	XL0037-103

- Weight : 10g
- Target: suction stems (large), suction stems non-rotate (1/8 series), suction stems non-rotate (large)

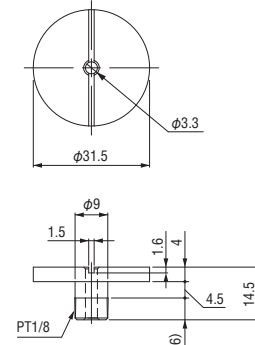

Quick Chuck Change

Quick Chuck Change Manual

Quick Chuck Change Manual (OM Type)

Tool Changer

Automated Hand Exchange System

Grip

Mini Cylinder

Accessories for Mini Cylinder

Container Cylinders

Accessories for Container Cylinder

Grippers

Rubber Material / Grip Pad

Suction

Suction Cups

Suction Stems

Pad in Pad

Vacuum Gripper

Air Ejector / Filter / Check Valve

Ultra Small Part Take Out

Vacuum Generator Unit

Cut

Air Nipper (Small-Medium)

Air Nipper (Large)

Frame / Module

Jungle Gym

Let's Joint

Rectangular Tube

Base Aluminum Material

Sliding Chuck

Pneumatic Components / Sensors

Pneumatic Components

Sensors / Multi AND Board

PCIO Communication Unit

Lightweight Parts Series

Frame / Suction / Resin Cylinders / Pads / Resin Manifolds

By Industry

Logistics - Palletizing / Sheet Metal - Stamping - Metal Fabrication

Assembling Tools

Tool / Jig

Information

Various Products Information



Suction Stems Non-Rotate (Micro/Mini/Small)



Direct connection on jungle gym series parts is possible.

Exchangeable head for suction stem.

- Suction cup is sold separately.
- Suction attach head is removable.

Suction stems non-rotate (micro)		
Drawing		
Order code No.	210823	210824
TYPE	VFILB-MSH	VFILB-MSH-P8
Weight	5g	6g
Piping/Mounting	φ4 / M6 P=0.75	φ4 / φ8
Applicable cup size	VAPH-4 (6)M → 3-4 / VAPH (F)-3C-3 → 3-6 / φ1.2~3.5 → 3-15,19	

* See [3-23](#) for more details about suction stem accouchement head M3 micro.

▶ Option of VFILB-SSH

Suction stems attachment head M5 mini

Order code No.	131208
TYPE	N01892-201

● Mounting screw M5 ● W/ gasket

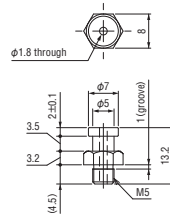

▶ Option of VFILB-SH

Suction stems attachment head M5 small

Order code No.	131209
TYPE	N01892-301

● Mounting screw M5 ● W/ gasket

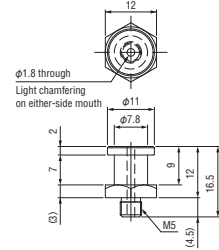

Suction stems non-rotate (mini)				
Drawing				
Order code No.	211041	211042	211043	211044
TYPE	VFILB2-SSH	VFILB2-SSH-P12	VFILB2-SSH-20	VFILB2-SSH-20-P12
Weight	28g	20g	31g	24g
Piping/Mounting	φ6 / M10 P=1.0	φ6 / φ12	φ6 / M10 P=1.0	φ6 / φ12
Applicable cup size	φ4 ~ 14 → 3-4,7,8 / TR-1062-1 ~ 4M → 3-6 / φ1.2 ~ 3.5 → 3-15			

Suction stems non-rotate (small)				
Drawing				
Order code No.	211045	211046	211047	211048
TYPE	VFILB2-SH	VFILB2-SH-P12	VFILB2-SH-20	VFILB2-SH-20-P12
Weight	32g	25g	35g	27g
Piping/Mounting	φ6 / M10 P=1.0	φ6 / φ12	φ6 / M10 P=1.0	φ6 / φ12
Applicable cup size	φ5 ~ 45 → 3-4,5,6,7,8 / TR-1062-1 ~ 4 → 3-6 / SQN type is φ5 ~ 22 → 3-15,17,18			

* Please remove the suction attach head when using suction cup with mounting bracket.



Suction Stems Non-Rotate (1/8 Connection / Angle / Large)



Direct connection on jungle gym series parts is possible.

Exchangeable head for suction stem.

● Suction cup is sold separately. Ensure that the suction attachment head and the suction pad with metal fittings are securely attached prior to use.

Suction stems non-rotate mini (1/8)				
Drawing				
Order code No.	211049	211050	211051	211052
TYPE	VFILB2-SH 1/8	VFILB2-SH 1/8-P12	VFILB2-SH 1/8-20	VFILB2-SH 1/8-20-P12
Weight	25g	19g	27g	22g
Piping/Mounting	φ6 / M10 P=1.0	φ6 / φ12	φ6 / M10 P=1.0	φ6 / φ12
Applicable cup size	φ15 ~ 118 → 3-5,6,7,8,10,11,12,13,16,17,18,19,20			

* Mounting bracket of suction cup is not attached. Use suction attach head-embedded type for small [3-29](#)

Suction stems non-rotate (angle adjustment)				
Drawing				
Order code No.	210991	210993	210992	210994
TYPE	VFILBR-H-10	VFILBR-H-10-P12	VFILBR-H-20	VFILBR-H-20-P12
Weight	33g	27g	36g	30g
Piping/Mounting	φ6 / M10 P=1.0	φ6 / φ12	φ6 / M10 P=1.0	φ6 / φ12
Applicable cup size	φ5 ~ 45 → 3-4,5,6,7,8 / TR-1062-1 ~ 4 → 3-6 / SQN type is φ5 ~ 22 → 3-15,16,17,18,19,20			

* Joint for air supply hole is not included. * Mounting bracket of suction cup is not attached. Use suction attach head M5 mini/small [3-30](#)

Suction Stems Non-Rotate (Large)	
Drawing	
Order code No.	210788
TYPE	VFIL-H
Weight	102g
Piping/Mounting	φ6 (RBF → 6-6) and BF-6 → 6-5 are necessary for piping / φ20
Applicable cup size	φ15 ~ 118 → 3-20

* Joint for air supply hole is not included.

* Mounting bracket of suction cup is not attached.

Use suction attach head [3-29](#).

● Since the tip is PT1/8 female screw, fixture 1/8G of special cup is supported.

Quick Chuck Change

Quick Chuck Change Manual

Quick Chuck Change Manual (OM Type)

Tool Changer

Automated Hand Exchange System

Grip

Mini Cylinder

Accessories for Mini Cylinder

Container Cylinders

Accessories for Container Cylinder

Grippers

Rubber Material / Grip Pad

Suction

Suction Cups

Suction Stems

Pad in Pad

Vacuum Gripper

Air Ejector / Filter / Check Valve

Ultra Small Part Take Out

Vacuum Generator Unit

Cut

Air Nipper (Small-Medium)

Air Nipper (Large)

Frame / Module

Jungle Gym

Let's Joint

Rectangular Tube

Base Aluminum Material

Sliding Chuck

Pneumatic Components / Sensors

Pneumatic Components

Sensors / Multi AND Board

PCIO Communication Unit

Lightweight Parts Series

Frame / Section / Resin Cylinders / Pads / Resin Manifolds

By Industry

Logistics - Palletizing / Sheet Metal - Stamping - Metal Fabrication

Assembling Tools

Tool / Jig

Information

Various Products Information



Suction Stems with Locking Mechanism



Direct connection on jungle gym series parts is possible.

Non-rotating suction stems. These feature a long stroke, these feature a long stroke and the ability to lock the stems position.



Suction stems locking mechanism 50mm

Order code No.	110556
TYPE	L10761-200

- Weight : 200g
- Piping : $\phi 6$ (RBF **6-6**) and BF-6 (**6-5**) are necessary for piping)
- Mounting : $\phi 20$

* Besides the piping for suction, it requires separated piping to the stopper cylinder.

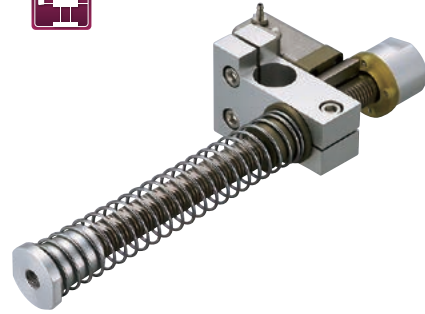
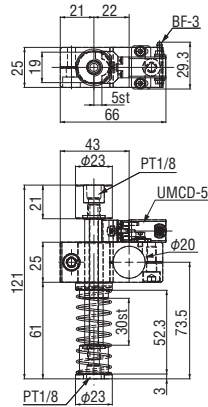

Suction stems locking mechanism 100mm

Order code No.	110565
TYPE	L10761-100

- Weight : 560g
- Piping : $\phi 6$ (RBF **6-6**) and BF-6 (**6-5**) are necessary for piping)
- Mounting : $\phi 20$

* Besides the piping for suction, it requires separated piping to the stopper cylinder.

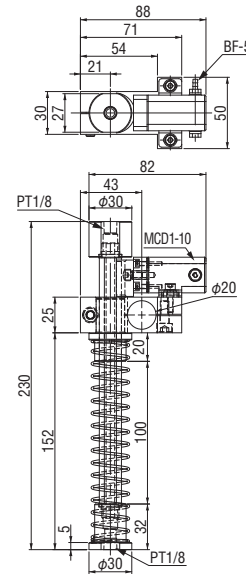

Reference drawing

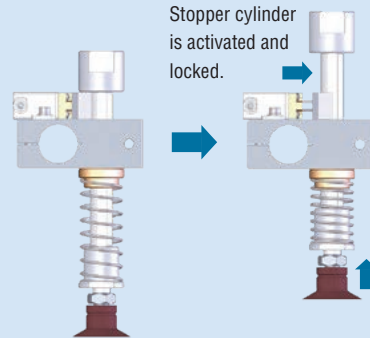

Suction stems attachment head, embedded type, small

Order code No.	230066
TYPE	XL0037-106

- Weight : 5g
- Target: suction stem (large), suction stem non-rotate (1/8series), suction stem non-rotate (large)



Suction stems attachment head, screw attach type

Order code No.	230067
TYPE	XL0037-103

- Weight : 10g
- Target: suction stem (large), suction stem non-rotate (1/8series), suction stem non-rotate (large)



Suction Stems Attachment Head

Please use this on the suction cups.

	M3, micro	M5, mini	M5, small	PT1/8 · small	Screw attach type
Suction Attachment head					
Drawing					
Order code No.	131316	131208	131209	230066	230067
TYPE	N01891-201	N01892-201	N01892-301	XL0037-106	XL0037-103
Weight	1.0g	3.1g	7.8g	5.0g	10g
Mounting	M3	M5	M5	PT1/8	PT1/8
Applicable cup size	VAPH-4M,6M / VAPH-3C-3 / VAPF-3C-3	VAPH,VAPU,VAPF,VAPN φ4 ~ 14 / TR,TRN-1062-1M ~ 4M	VAPH,VAPU,VAPF,VAPN φ15 ~ 45 / TR,TRN-1062-1 ~ 4		VAPH,VAPU,VAPF,VAPN φ50 or higher

	M5 · For EPCG15/20	M5 · For EPCG30/40	M5(for vacuum cups)	M5(for vacuum cups)
Suction Attachment head				
Drawing				
Order code No.	211102	211103	042111	042112
TYPE	VFILK-AH01	VFILK-AH02	ETN-PS-2A-M5	ETN-PS-10-M5
Weight	3.0g	8.0g	0.5g	0.8g
Mounting	M5	M5	M5	M5
Applicable cup size	EPCG-15,20	EPCG-30,40	EPCG-3 / EPJG-2,4	EPJG-6,8,10,15

	For PT1/8 A (For Pouch, Multistage Cups)	For PT1/8 B (For Pouch, Multistage Cups)	For PT1/8 C (For Pouch, Multistage Cups)	For PT1/8 D (For Pouch, Multistage Cups)
Suction Attachment head				
Drawing				
Order code No.	211114	211115	211116	211117
TYPE	VFILA-PHA-1/8	VFILA-PHB-1/8	VFILA-PHC-1/8	VFILA-PHD-1/8
Weight	4.0g	13.0g	18.0g	34.0g
Mounting	M3	M5	M5	PT1/8
Applicable cup size	EPLG-15,20 / EPMG-24 / EPNG-132B,133B,134B	EPLG-30 / EPMG-40	EPLG-40 / EPMG-56	EPLG-50

Quick Chuck Change

Quick Chuck Change Manual

Quick Chuck Change Manual (OM Type)

Tool Changer

Automated Hand Exchange System

Grip

Mini Cylinder

Accessories for Mini Cylinder

Container Cylinders

Accessories for Container Cylinder

Grippers

Rubber Material / Grip Pad

Suction

Suction Cups

Suction Stems

Pad in Pad

Vacuum Gripper

Air Ejector / Filter / Check Valve

Ultra Small Part Take Out

Vacuum Generator Unit

Cut

Air Nipper (Small-Medium)

Air Nipper (Large)

Frame / Module

Jungle Gym

Let's Joint

Rectangular Tube

Base Aluminum Material

Sliding Chuck

Pneumatic Components / Sensors

Pneumatic Components

Sensors / Multi AND Board

PCIO Communication Unit

Lightweight Parts Series

Frame / Section / Resin Cylinders / Pads / Resin Manifolds

By Industry

Logistics-Palletizing / Sheet Metal-Stamping- Metal Fabrication

Assembling Tools

Tool / Jig

Information

Various Products Information

















Suction Stems ↔ Suction Cups Selection Table

Please choose the target products from pad size and suction stem.

	bracket	Suction stems				Suction stems non-rotate					
		Suction stems(micro) VFILB-M	Suction Stems(mini) VFIL-SS VFILP-SS	Suction stems(small) VFIL-S VFILP-S	Suction stems(large) VFI-L	Suction stems non-rotate(micro) VFILB-MSH	Suction stems non-rotate(mini) VFILB2-SSH	Suction stems non-rotate(small) VFILB2-SH	Suction stems non-rotate mini(1/8) VFILB2-SH	Suction stems non-rotate(adjustment) VFILBR-H	Suction Stems Non-Rotate(Large) VFIL-H
○ : can be mounted × : It can not be installed.	Applicable cup size										
Suction Cups 	φ 3mm	○	×	×	×	○	×	×	×	×	×
	φ 4mm (micro)	○	×	×	×	○	×	×	×	×	×
	φ 6mm (micro)	○	×	×	×	○	×	×	×	×	×
	φ 4mm	×	○	×	×	×	○	×	×	○ Select C.	×
	φ 6mm	×	○	×	×	×	○	×	×		×
	φ 8mm	×	○	×	×	×	○	×	×		×
	φ 10mm	×	○	×	×	×	○	×	×		×
	φ 12mm	×	○	×	×	×	○	×	×	×	×
	φ 14mm	×	○	×	×	×	○	×	×	×	×
	φ 15mm	×	×	○	○ Select A.	×	×	○	○ Select A.	○ Select D.	○ Select A.
	φ 20mm	×	×	○		×	×	○			
	φ 25mm	×	×	○		×	×	○			
	φ 30mm	×	×	○		×	×	○			
	φ 35mm	×	×	○		×	×	○			
	φ 40mm	×	×	○	○ Select B.	×	×	×	○ Select B.	×	○ Select B.
φ 45mm	×	×	○	×		×	×				
φ 50mm	×	×	×	×		×	×				
φ 60mm	×	×	×	×	×	×	×	×	×	×	
φ 70mm	×	×	×	×	×	×	×	×	×	×	
Suction Cups (mini) 	φ 6mm	×	○	×	×	○	×	×	○ Select C.	×	
	φ 8mm	×	○	×	×	○	×	×		×	
	φ 10mm	×	○	×	×	○	×	×		×	
	φ 12mm	×	○	×	×	○	×	×		×	
Suction Cups (small) 	φ 6mm	×	×	○	○ Select A.	×	×	○	○ Select A.	○ Select D.	○ Select A.
	φ 8mm	×	×	○		×	×	○			
	φ 10mm	×	×	○		×	×	○			
	φ 12mm	×	×	○		×	×	○			
Vacuum Caps 	φ 2mm	×	×	○* 2 Select I.	×	×	○* 1 Select I.	○* 1 Select I.	×	○ Select I.	×
	φ 4mm	×	×	×	×	×	○* 1 Select I.	○* 1 Select I.	×	○ Select I.	×
	φ 6mm	×	×	×	×	×	○* 1 Select J.	○* 1 Select J.	×	○ Select J.	×
	φ 8mm	×	×	×	×	×	○* 1 Select J.	○* 1 Select J.	×	○ Select J.	×
	φ 10mm	×	×	×	×	×	○* 1 Select J.	○* 1 Select J.	×	○ Select J.	×
	φ 15mm	×	×	×	×	×	×	×	×	×	×
Fluorine Bellows Cups 	φ 3mm	○	×	×	×	○	×	×	×	×	×
	φ 15mm	×	×	×	×	×	○* 1 Select K.	○* 1 Select K.	×	○ Select K.	×
	φ 20mm	×	×	×	×	×	○* 1 Select K.	○* 1 Select K.	×	○ Select K.	×
	φ 30mm	×	×	×	×	×	○* 1 Select L.	○* 1 Select L.	×	○ Select L.	×
	φ 40mm	×	×	×	×	×	○* 1 Select L.	○* 1 Select L.	×	○ Select L.	×
Steel Sheet Cup 	φ 30mm	×	×	×	○	×	×	×	○	×	○
	φ 60mm	×	×	×	○	×	×	×	○	×	○
Bellows Cup (transparent white silicone) 	φ 3mm	×	×	×	×	×	○* 1 Select I.	×	×	○ Select I.	×
Multistage Bellows 	φ 15mm	×	×	×	○ Select E.	×	×	×	○ Select E.	×	○ Select E.
	φ 20mm	×	×	×	○ Select F.	×	×	×	○ Select F.	×	○ Select F.
	φ 30mm	×	×	×	○ Select G.	×	×	×	○ Select G.	×	○ Select G.
	φ 40mm	×	×	×	○ Select H.	×	×	×	○ Select H.	×	○ Select H.
	φ 50mm	×	×	×	○ Select H.	×	×	×	○ Select H.	×	○ Select H.
Pouch Cups (round) 	φ 18mm	×	×	×	○ Select E.	×	×	×	○ Select E.	×	○ Select E.
	φ 25mm	×	×	×		×	×	×		×	
	φ 35mm	×	×	×		×	×	×		×	
Pouch Cups (Star-Shaped) 	φ 24mm	×	×	×	○ Select E.	×	×	×	○ Select E.	×	○ Select E.
	φ 40mm	×	×	×	○ Select F.	×	×	×	○ Select F.	×	○ Select F.
	φ 56mm	×	×	×	○ Select G.	×	×	×	○ Select G.	×	○ Select G.

* The cups in bold frame require the "attach head" when mounting. Choose A ~ L from the bottom of the next page.

	Applicable cup size	Suction stems				Suction stems non-rotate					
		Suction stems(micro) VFILB-M	Suction Stems(mini) VFIL-SS VFILP-SS	Suction stems(small) VFIL-S VFILP-S	Suction stems(large) VFI-L	Suction stems non-rotate(micro) VFILB-MSH	Suction stems non-rotate(mini) VFILB2-SSH	Suction stems non-rotate(small) VFILB2-SH	Suction stems non-rotate mini(FI) VFILB2-SH	Suction stems non-rotate(angle adjustment) VFILBR-H	Suction Stems Non-Rotate(Large) VFIL-H
Bellows type Suction Cups 	φ 1.2mm			×	×		×	×	×	×	×
	φ 1.8mm	○* 1	○* 2	×	×	○* 1	×	×	×	×	×
	φ 2mm			×	×		×	×	×	×	×
	φ 3.5mm			×	×		×	×	×	×	×
	φ 5mm	×	×		×	×			×	○	×
	φ 5.5mm	×	×		×	×			×	○	×
	φ 6mm	×	×		×	×			×	○	×
	φ 6.5mm	×	×		×	×			×	○	×
	φ 8mm	×	×		×	×			×	○	×
	φ 9.3mm	×	×		×	×			×	○	×
	φ 10mm	×	×		×	×			×	○	×
	φ 11mm	×	×		×	×			×	○	×
	φ 12.7mm	×	×	○* 2	×	×	○* 1	○* 1	×	○	×
	φ 13mm	×	×		×	×			×	○	×
	φ 15mm	×	×		×	×			×	○	×
	φ 16mm	×	×		×	×			×	○	×
	φ 18.5mm	×	×		×	×			×	○	×
	φ 19mm	×	×		×	×			×	○	×
	φ 20mm	×	×		×	×			×	○	×
	φ 22mm	×	×		×	×			×	○	×
φ 24mm	×	×	×	○	×			○	×	○	
φ 24.7mm	×	×	×	○	×	×	×	○	×	○	
φ 25mm	×	×	×	○	×	×	×	○	×	○	
φ 30mm	×	×	×	○	×	×	×	○	×	○	
φ 32.6mm	×	×	×	○	×	×	×	○	×	○	
φ 33mm	×	×	×	○	×	×	×	○	×	○	
φ 35mm	×	×	×	○	×	×	×	○	×	○	
φ 40mm	×	×	×	○	×	×	×	○	×	○	
φ 43mm	×	×	×	○	×	×	×	○	×	○	
φ 43.5mm	×	×	×	○	×	×	×	○	×	○	
φ 50mm	×	×	×	○	×	×	×	○	×	○	
φ 52.5mm	×	×	×	○	×	×	×	○	×	○	
φ 53mm	×	×	×	○	×	×	×	○	×	○	
φ 60mm	×	×	×	○	×	×	×	○	×	○	
φ 62.2mm	×	×	×	○	×	×	×	○	×	○	
φ 63mm	×	×	×	○	×	×	×	○	×	○	
φ 80mm	×	×	×	○	×	×	×	○	×	○	
φ 83mm	×	×	×	○	×	×	×	○	×	○	
φ 103mm	×	×	×	○	×	×	×	○	×	○	
φ 118mm	×	×	×	○	×	×	×	○	×	○	
Suction Cups (Oval with metal fittings) 	2×4mm	○* 1	○* 2	×	×	○* 1	×	×	×	×	×
	3.5×7mm			×	×		×	×	×	×	×
	5×15mm	×	×	○* 2	×	×	○* 1	○* 1	×	○	×
	6×18mm	×	×		×	×			×	○	×
	8×24mm	×	×	×	○	×	×	×	○	×	○
10×30mm	×	×	×	○	×	×	×	○	×	○	
* 3	15×45mm	×	×	×	○	×	×	○	×	○	

Attachment head to use											
A	B	C	D	E	F	G	H	I	J	K	L
Suction stems attachment head, embedded type, small	Suction stems attachment head, screw attach type	Suction stems attachment head M5 mini	Suction stems attachment head M5 small	Inner stems attachment head • For PT1/8 A	Inner stems attachment head • For PT1/8 B	Inner stems attachment head • For PT1/8 C	Inner stems attachment head • For PT1/8 D	Outer stems attachment head • 2A • M5	Outer stems attachment head • 10 • M5	Suction stems head • M5 • for EPCG 15/20	Suction stems head • M5 • for EPCG 30/40
											
PT1/8 mounting hole	PT1/8 mounting hole	M5 mounting hole	M5 mounting hole	PT1/8 mounting hole	PT1/8 mounting hole	PT1/8 mounting hole	PT1/8 mounting hole	M5 mounting hole	M5 mounting hole	M5 mounting hole	M5 mounting hole
230066	230067	131208	131209	211114	211115	211116	211117	042111	042112	211102	211103

- * 1 Please remove the suction Stems attachment head at the tip before use.
- * 2 Attach it to the head of the screw holes and use it. Can't be attached to the suction resin (VFILP).
- * 3 The Photograph shows the silicon suction cups. It is applies for different materials (markless rubber).

Quick Chuck Change

- Quick Chuck Change Manual
- Quick Chuck Change Manual (OM Type)
- Tool Changer
- Automated Hand Exchange System

Grip

- Mini Cylinder
- Accessories for Mini Cylinder
- Container Cylinders
- Accessories for Container Cylinder
- Grippers
- Rubber Material / Grip Pad

Suction

- Suction Cups
- Suction Stems
- Pad in Pad

Vacuum Gripper

- Air Ejector / Filter / Check Valve
- Ultra Small Part Take Out
- Vacuum Generator Unit

Cut

- Air Nipper (Small-Medium)
- Air Nipper (Large)

Frame / Module

- Jungle Gym
- Let's Joint
- Rectangular Tube
- Base Aluminum Material
- Sliding Chuck

Pneumatic Components / Sensors

- Pneumatic Components
- Sensors / Multi AND Board
- PCIO Communication Unit

Lightweight Parts Series

- Frame / Suction / Resin Cylinders / Pads / Resin Manifolds

By Industry

- Logistics-Palletizing/Sheet Metal-Stamping-Metal Fabrication

Assembling Tools

- Tool / Jig

Information

- Various Products Information



Suction Stems Fixed/for Mini Cylinder

Use as your situation.

● Suction cup and joint are optionally available.

▶ Use by mounting a Bellows cups.



Suction stems fixed mini

Order code No.	210699
TYPE	VFILK-SS-M10

- Weight : 6g
- Applicable cup size : $\phi 4 \sim 14$
- Cup fixing system: embedded
- Suction stem nut (3-37) is not attached.
- Mounting screw part : M10×P1

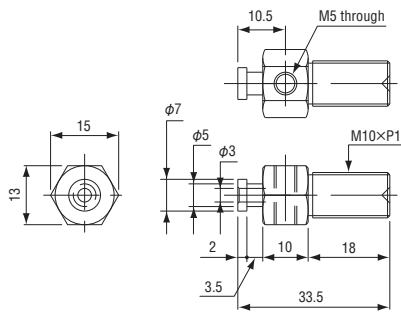

Suction stems fixed for small

Order code No.	210698
TYPE	VFILK-S-M12

- Weight : 9g
- Applicable cup size : $\phi 15 \sim 45$
- Cup fixing system: embedded
- Suction stem nut (3-37) is not attached.
- Mounting screw part : M12×P1

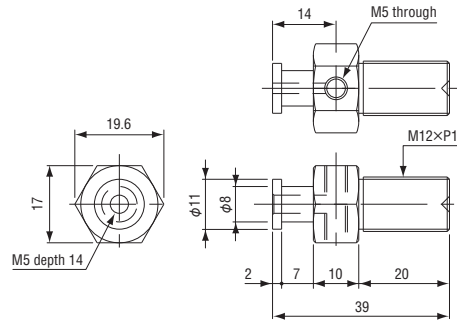

▶ Used when suction cups is attached to the end of mini cylinder.



Suction stems mini for micro mini cylinder

Order code No.	230058
TYPE	XL0010-105

- Weight : 1g
- Mounting screw part : M3

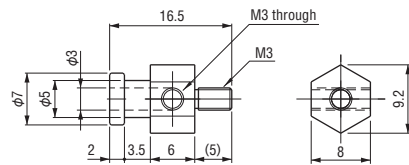

Suction stems mini for mini cylinder

Order code No.	020844
TYPE	CP-064

- Weight : 7g
- Mounting screw part : M4

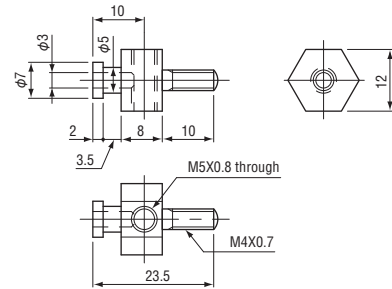

Suction stems small for micro mini cylinder

Order code No.	023128
TYPE	CP-063A

- Weight : 10g
- Mounting screw section M3

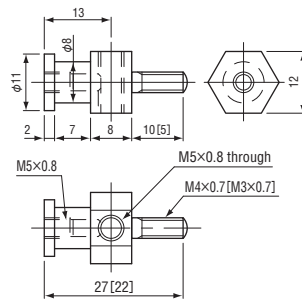

Suction stems small for mini cylinder

Order code No.	023195
TYPE	CP-063B

- Weight : 11g
- Mounting screw section M4

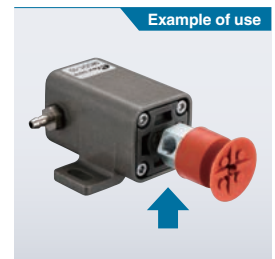

* Picture shows CP-063B assembled with MCD-10 and VAPH-20C-1.



Adjuster

Height of suction stem can be adjusted.

► Extension between suction cup and stem is possible.



Suction stems bracket micro

Order code No.	230072
TYPE	XL0061-100

- 重量 : 2g
- Mounting screw part : M3

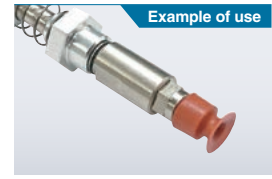
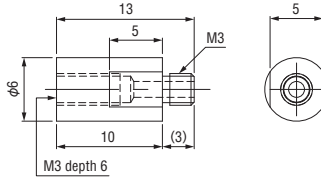

Suction stems bracket mini

Order code No.	230114
TYPE	XL0061-200

- 重量 : 3g
- Mounting screw part : M5

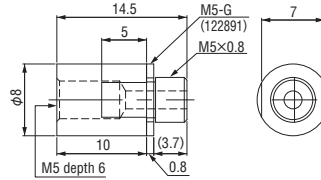

Suction stems bracket • mini (For Suction stems 5st)

	20L	40L
Order code No.	022544	022545
TYPE	CP-023AL (20L)	CP-024AL (40L)

- Weight : 17g (20L) 21g (40L)
- Targetsuction stem : VFIL1-SS-5
- Suction stem nut is not attached.

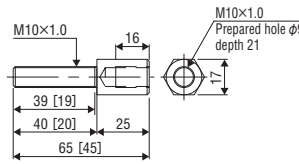

* Size in [] shows size of 20L.

Suction stems bracket • mini (For Suction stems 5/10/20st)

	20L	40L
Order code No.	023338	023339
TYPE	CP-AJM20	CP-AJM40

- Weight : 24g (20L) 28g (40L)
- Targetsuction stem : VFIL1-SS-5/10/20
- Suction stem nut is not attached.

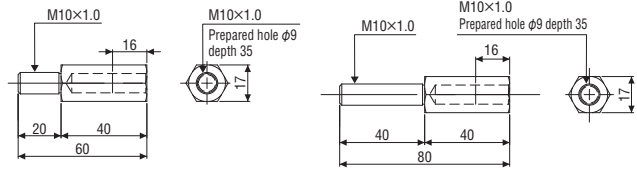

Suction stems nut • mini (trivalent white)

Order code No.	120482
TYPE	VFIL-M10 (10*14*3 P1.0)

- Weight : 2g
- Screw diameter : M10

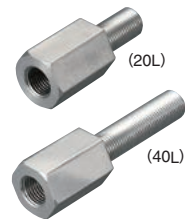
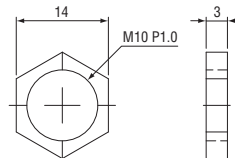

Suction stems bracket • small (For Suction stems 5st)

	20L	40L
Order code No.	022542	022543
TYPE	CP-021AL (20L)	CP-022AL (40L)

- Weight : 17g (20L) 23g (40L)
- Targetsuction stem : VFIL-S-5
- Suction stem nut is not attached.

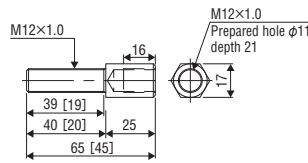

* Size in [] shows size of 20L.

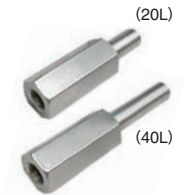

Suction stems bracket • small (For Suction stems 5/10/20st)

	20L	40L
Order code No.	023340	023341
TYPE	CP-AJS20	CP-AJS40

- Weight : 25g (20L) 31g (40L)
- Targetsuction stem : VFIL1-S-5/10/20
- Suction stem nut is not attached.

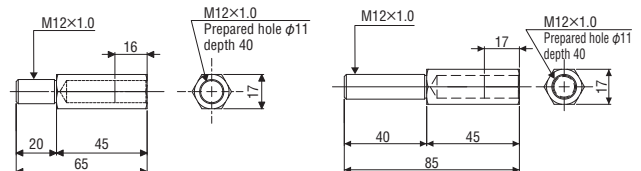

Suction stems nut • small (trivalent white)

Order code No.	120483
TYPE	VFIL-M12 (12*17*3 P1.0)

- Weight : 3g
- Screw diameter : M12

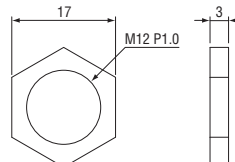

Quick Chuck Change

Quick Chuck Change Manual

Quick Chuck Change Manual (OM Type)

Tool Changer

Automated Hand Exchange System

Grip

Mini Cylinder

Accessories for Mini Cylinder

Container Cylinders

Accessories for Container Cylinder

Grippers

Rubber Material / Grip Pad

Suction

Suction Cups

Suction Stems

Pad in Pad

Vacuum Gripper

Air Ejector / Filter / Check Valve

Ultra Small Part Take Out

Vacuum Generator Unit

Cut

Air Nipper (Small-Medium)

Air Nipper (Large)

Frame / Module

Jungle Gym

Let's Joint

Rectangular Tube

Base Aluminum Material

Sliding Chuck

Pneumatic Components / Sensors

Pneumatic Components

Sensors / Multi AND Board

PCIO Communication Unit

Lightweight Parts Series

Frame / Suction / Resin Cylinders / Pads / Resin Manifolds

By Industry

Logistics - Palletizing / Sheet Metal - Stamping - Metal Fabrication

Assembling Tools

Tool / Jig

Information

Various Products Information



Suction Stems Angle Brackets

The angle can be adjusted according to the shape of workpiece.



Suction stems angle bracket (upper)

Order code No.	370698
TYPE	CP-019

- Weight : 48g
- Fixing bolt M5x15 is available separately.
- Assembly of parts is not available in delivery for an order.
- Use with CP-019L or CP-019R.

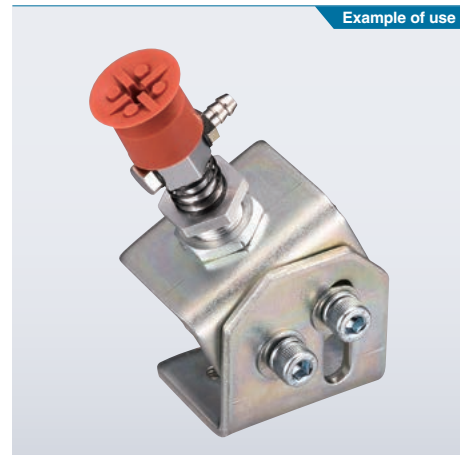
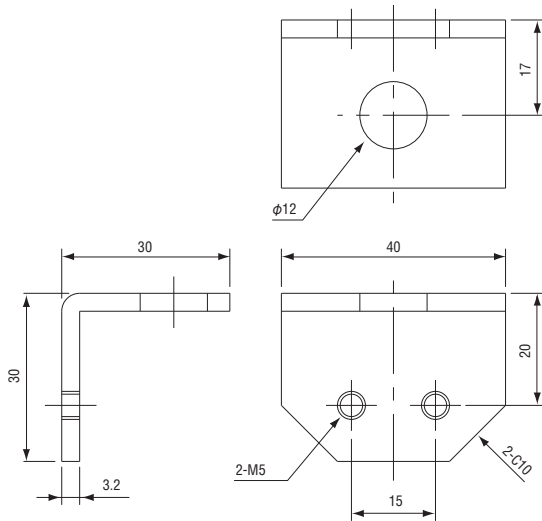

● Photo shows right-hand mount type (CP-019R).



Suction stems angle bracket (L-lower)

Order code No.	370789
TYPE	CP-019L

- Weight : 54g
- Fixing bolt M5x15 is available separately.
- Assembly of parts is not available in delivery for an order.
- Use with CP-019.

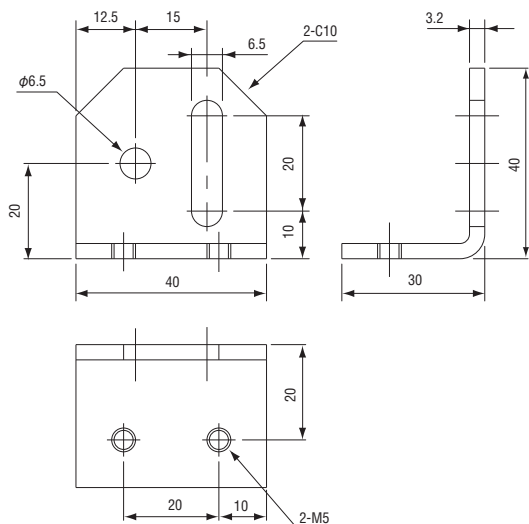

Suction stems angle bracket (R-lower)

Order code No.	370790
TYPE	CP-019R

- Weight : 54g
- Fixing bolt M5x15 is available separately.
- Assembly of parts is not available in delivery for an order.
- Use with CP-019.

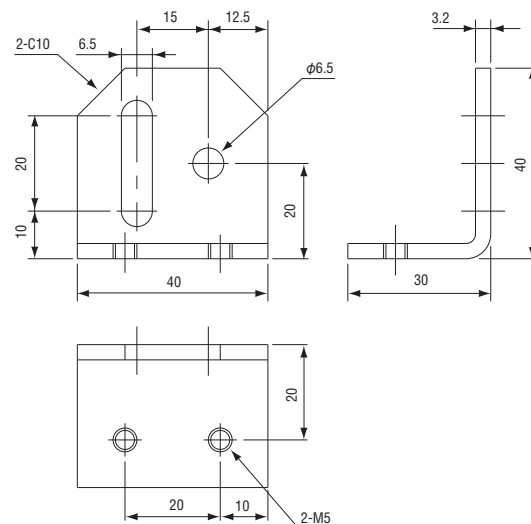

MEMO

A series of horizontal dashed lines for writing.



Pad in Pad

Do you have some problems with work piece with holes (food container, cap and inner stopper for cosmetic container, and small gear) which falls automatically? Pad in Pad can be used for molded parts with holes in them.

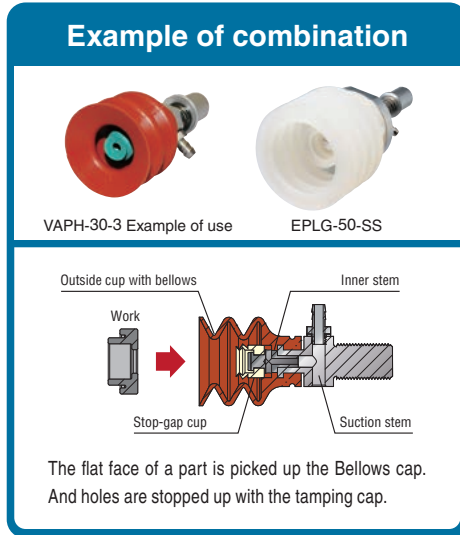

Stems spacer

Stems spacer		
Drawing		
Order code No.	210913	187128
TYPE	VFILK-P-S	SP-S5-6
Weight	0.3g	2.0g
Applicable stem	-	

Inner Stems

Inner stems						
Drawing						
Order code No.	210911	210912	211118	211119	211120	211121
TYPE	VFILK-PS-M5	VFILK-PSS-M5	VFILK-PIA-M5	VFILK-PIB-M5	VFILK-PIC-M5	VFILK-PID-M5
Weight	1.5g	1.0g	1.0g	2.0g	4.0g	5.0g
Applicable inner pad	EPJG-(6,8,10,15)-S	Reinforced silicone (brown)	EPJG-(6,8)-S	EPJG-(10,15)-S	EPJG-(20,25)-S	EPJG-30-S
Applicable stem	Suction stem small (also for some suction stem mini products)		VFILA-(B,C,D)-1/8		VFILA-(C,D)-1/8	VFILA-D-1/8

* when ordering the inner stem, please purchase with gasket (122891). → **6-8**

Outside Stems

Outside stems			
Drawing			
Order code No.	211115	211116	211117
TYPE	VFILA-PHB-1/8	VFILA-PHC-1/8	VFILA-PHD-1/8
Weight	13.0g	18.0g	34.0g
Applicable inner pad	EPLG-30-S5, EPLG-40L	EPLG-40-S5	EPLG-50-S5
Applicable stem	Suction stems large, non-rotate (1/8 large)		

The combination of pad in pad, please refer to the selection table **3-42**.



Please check the performance table on the web site.

Pad in Pad



You can see moving images of products by using QR code reader of your smartphone.

▶ Inner Cups

Material	Reinforced silicone (brown)			Silicone (transparent white)	
Applicable cup size	φ 3mm	φ 4mm	φ 6mm	φ 6mm	φ 8mm
Inner cup		* Micro	* Micro		
Drawing					
Order code No.	210897	210789	210790	042038	042039
TYPE	VAPH-3C-3	VAPH-4M	VAPH-6M	EPJG-6-S	EPJG-8-S
Weight	1.0g	0.2g	0.3g	0.15g	0.25g
Applicable stem	Micro, VFILK-PSS-M5			Mini, VFILK-PS-M5, VFILK-PIA-M5	

Material	Silicone (transparent white)				
Applicable cup size	φ 10mm	φ 15mm	φ 20mm	φ 25mm	φ 30mm
Inner cup					
Drawing					
Order code No.	042040	042041	042068	042069	042070
TYPE	EPJG-10-S	EPJG-15-S	EPJG-20-S	EPJG-25-S	EPJG-30-S
Weight	0.45g	1.0g	1.6g	2.7g	5.0g
Applicable stem	Mini, VFILK-PS-M5, VFILK-PIB-M5		VFILK-PIC-M5		VFILK-PID-M5

▶ Outside Cups

Material	Reinforced silicone (brown)				Silicone (transparent white)		
Applicable cup size	φ 15mm	φ 20mm	φ 30mm	φ 40mm	φ 30mm	φ 40mm	φ 50mm
Outside cup							
Drawing							
Order code No.	210697	210661	210662	210663	042071	042072	042073
TYPE	VAPH-15C-3	VAPH-20C-3	VAPH-30C-3	VAPH-40C-3	EPLG-30-S5	EPLG-40-S5	EPLG-50-S5
Weight	2.7g	2.9g	7.0g	18.4g	6.9g	15.7g	20.8g
Applicable inner pad	VAPH-4M/6M, VAPH-3C-3	EPJG-6-S/8-S	EPJG-6-S~EPJG10-S	EPJG-6-S~EPJG15-S	EPJG-(8,10)-S	EPJG-(8,15,20)-S	EPJG-(8~30)-S
Applicable stem	Small, VFIL-S, or VFILB-SH → (3-26,27,28,30)				VFILA-PHB-1/8	VFILA-PHC-1/8	VFILA-PHD-1/8

Pad in Pad test kit

Please try out Pad in Pad with our test kit!!



Pad in Pad test kit (1)

Order code No.	196688
TYPE	TEST KIT VERSION (1)

■ Contents

Page	Product name	Order code No.	TYPE	Qty	Applicable cup size
Outside cup with bellows	① Bellow Suction Cups (silicon, brown)	210697	VAPH-15C-3	1	⑦⑧
	② Bellow Suction Cups (silicon, brown)	210661	VAPH-20C-3	1	⑦⑧⑩⑪
	③ Bellow Suction Cups (silicon, brown)	210662	VAPH-30C-3	1	⑦⑧⑩⑪⑫
	④ Bellow Suction Cups (silicon, brown)	210663	VAPH-40C-3	1	⑦~⑫
	⑤ Bellow Suction Cup w/ sponge (silicon, brown)	210914	VAPH-20C-10-3-SP	1	⑦⑧⑩⑪
	⑥ Bellow Suction Cup w/ sponge (silicon, brown)	210915	VAPH-30C-15-3-SP	1	⑦⑧⑩⑪⑫
Stop-gap cup	⑦ Bellow Suction Cups (silicon, brown)	210897	VAPH-3C-3	1	①~⑥
	⑧ Suction Cups (standard/micro/brown)	210790	VAPH-6M (silicon)	1	①~⑥
	⑨ Suction Cups (standard/silicon/brown)	210616	VAPH-14C	1	④
	⑩ Suction Cup · Silicon	042038	EPJG-6-S	1	②~⑥
	⑪ Suction Cup · Silicon	042039	EPJG-8-S	1	②~⑥
	⑫ Suction Cup · Silicon	042040	EPJG-10-S	1	③④⑥
Inner stem	⑬ Pad-in inner stem for micro	210912	VFILK-PSS-M5	1	—
	⑭ Pad-in inner stem for mini	210911	VFILK-PS-M5	1	—
	⑮ Pad-in inner stem (spacer)	210913	VFILK-P-S	5	—
Suction stem	⑯ Suction stem for small	211006	VFIL1-S-5-P12	1	—
	⑰ Suction stem fixed for small	210698	VFILK-S-M12	1	—

Quick Chuck Change

Quick Chuck Change Manual

Quick Chuck Change Manual (OM Type)

Tool Changer

Automated Hand Exchange System

Grip

Mini Cylinder

Accessories for Mini Cylinder

Container Cylinders

Accessories for Container Cylinder

Grippers

Rubber Material / Grip Pad

Suction

Suction Cups

Suction Stems

Pad in Pad

Vacuum Gripper

Air Ejector / Filter / Check Valve

Ultra Small Part Take Out

Vacuum Generator Unit

Cut

Air Nipper (Small-Medium)

Air Nipper (Large)

Frame / Module

Jungle Gym

Let's Joint

Rectangular Tube

Base Aluminum Material

Sliding Chuck

Pneumatic Components / Sensors

Pneumatic Components

Sensors / Multi AND Board

PCIO Communication Unit

Lightweight Parts Series

Frame / Suction / Resin Cylinders / Pads / Resin Manifolds

By Industry

Logistics - Palletizing / Sheet Metal - Stamping - Metal Fabrication

Assembling Tools

Tool / Jig

Information

Various Products Information



Pad in Pad Selection List

Through the combination of parts selection, make it possible to take out even the parts with hole.

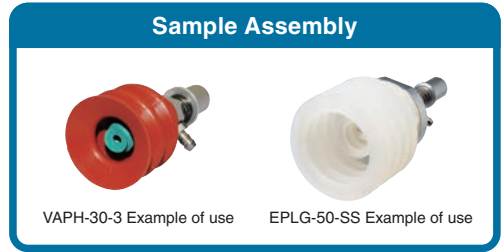
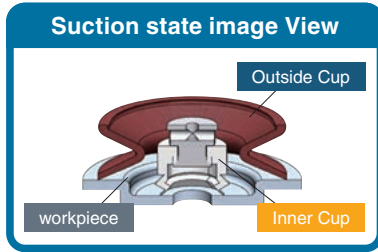
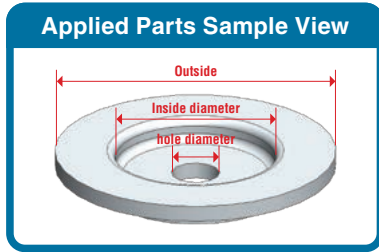

				Outside cup						
Order code No.	TYPE	Applicable cup size	Product outer diameter	210697	210661	210662	210663	042071	042072	042073
				VAPH-15C-3	VAPH-20C-3	VAPH-30C-3	VAPH-40C-3	EPLG-30-S5	EPLG-40-S5	EPLG-50-S5
				φ15	φ20	φ30	φ40	φ30	φ40	φ50
				φ8	φ11	φ15	φ18	φ19	φ25.7	φ35.7
Order code No.	TYPE	Applicable cup size	Product outer diameter Product hole diameter	φ12 or larger	φ15 or larger	φ19 or larger	φ22 or larger	φ21 or larger	φ26 or larger	φ37 or larger
Inner cup	210897	VAPH-3C-3	φ3 φ0.1~φ1	A	A	A	A			
				1.2,3 4.0mm	1.2,3 3.5mm	1.2,3 -0.5mm	1.2,3 -5.5mm			
	210789	VAPH-4M	φ4 φ0.1~φ1.5	A	A	A				
				1.2,3 4.0mm	1.2,3 ±0mm	1.2,3 -4.0mm				
	210790	VAPH-6M	φ6 φ0.1~φ3	A	A	A				
				1.2,3 4.5mm	1.2,3 0.5mm	1.2,3 -4.5mm				
	042038	EPJG-6-S	φ6 φ0.1~φ3	B	B	B				
				1.2,3 2.8mm	1.2,3 -1.2mm	1.2,3 -6.2mm				
	042039	EPJG-8-S	φ8 φ0.1~φ4					B,C	B,C	B,C
								G 1.2,3 -1.3mm	H 4.5,6 -5.8mm	I 4.5,6 -6.8mm
042040	EPJG-10-S	φ10 φ0.1~φ6						B,D	B,D	
								G 1.2,3 -0.3mm	H 4.5,6 -5.3mm	I 4.5,6 -6.8mm
042041	EPJG-15-S	φ15 φ0.1~φ10							D	D
									H 4.5,6 -5.2mm	I 4.5,6 -6.2mm
042068	EPJG-20-S	φ20 φ0.1~φ16							E	E
									H 4.5,6 -4.2mm	I 4.5,6 -5.2mm
042069	EPJG-25-S	φ25 φ0.1~φ20								E
										I 4.5,6 -4.1mm
042070	EPJG-30-S	φ30 φ0.1~φ24								F
										I 4.5,6 -0.8mm

A table view
Parts are selected from the following parts list.

- Inner stem
- Outer cup
- Suction stem
- Height difference

* Please use this setting table as a reference example of the combination.

部品リスト

Inner stem		
code	Order code No.	TYPE
A	210912	VFILK-PSS-M5
B	210911	VFILK-PS-M5
C	211118	VFILK-PIA-M5
D	211119	VFILK-PIB-M5
E	211120	VFILK-PIC-M5
F	211121	VFILK-PID-M5

Outer cup		
code	Order code No.	TYPE
G	211115	VFILA-PHB-1/8
H	211116	VFILA-PHC-1/8
I	211117	VFILA-PHD-1/8

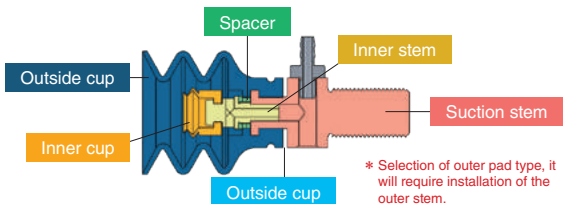

* Selection of outer pad type, it will require installation of the outer stem.

Suction stem		
code	Order code No.	TYPE
1		VFIL-S series
2		VFILB-2-SSH series
3		VFILB-SH series
4		VFIL-L series
5		VFILB2-SH1/8 series
6	210788	VFIL-H

Stem spacer		
code	Order code No.	TYPE
210913	1mm	VFILK-P-S
187128	6mm	SP-S5-6

The height difference between outer pad and inner pad during suction ON.

- + : The inner pad suction surface exceeds the outer pad suction surface.
- : The inner pad suction surface does not exceed the outer pad suction surface.

* It can not be adjusted from + value to -value. Therefore, combinations with a large + value can only be used for concave products.



You can see moving images of products by using QR code reader of your smartphone.

Quick Chuck Change

Quick Chuck Change Manual

Quick Chuck Change Manual (OM Type)

Tool Changer

Automated Hand Exchange System

Grip

Mini Cylinder

Accessories for Mini Cylinder

Container Cylinders

Accessories for Container Cylinder

Grippers

Rubber Material / Grip Pad

Suction

Suction Cups

Suction Stems

Pad in Pad

Vacuum Gripper

Air Ejector / Filter / Check Valve

Ultra Small Part Take Out

Vacuum Generator Unit

Cut

Air Nipper (Small-Medium)

Air Nipper (Large)

Frame / Module

Jungle Gym

Let's Joint

Rectangular Tube

Base Aluminum Material

Sliding Chuck

Pneumatic Components / Sensors

Pneumatic Components

Sensors / Multi AND Board

PCIO Communication Unit

Lightweight Parts Series

Frame / Suction / Resin Cylinders / Pads / Resin Manifolds

By Industry

Logistics-Palletizing/Sheet Metal-Stamping-Metal Fabrication

Assembling Tools

Tool / Jig

Information

Various Products Information

► Selection method

e.g.1 Products with through hole Outside : $\phi 25$ Hole diameter : $\phi 4$ Height difference : 0mm

- Inner cup**
The hole diameter of the product is $\phi 4$, so please select the pad that its hole diameter is more than $\phi 4$.
- Outside cup**
Since the outside diameter of the product is $\phi 25$, select a pad with an applicable-to-product outside diameter of $\phi 25$ or less.
- Spacer**
Choose the pad that the value of the green frame in the form is minus from the selected pad, and please add the spacer to make sure the difference of height turn to ± 0 when in suction.
* The tolerance of air leak: ± 0.5 mm height difference.
* If you have more options, please snarrowdown the selection of parts as meet to the conditions of pirce and/ or size of components.

e.g.2 Concave product Outside : $\phi 25$ Inside diameter : $\phi 18$ Hole diameter : $\phi 4$ Height difference : 2mm

- Inner cup**
The hole diameter of the product is $\phi 4$, so please select the pad that its hole diameter is more than $\phi 4$.
- Outside cup**
Since the outside diameter of the product is $\phi 25$ and the inside diameter of the product is $\phi 18$, select a pad with an applicable-to-product outside diameter of $\phi 25$ or less and the outside diameter is $\phi 18$ or more.
- Spacer**
Add a spacer so that the numerical value in the green box in the pad selection box can be +2mm in length.
* Note with care that if the adjusted length is less than 2mm, air leak will occur.
* The tolerance of air leak: ± 0.5 mm height difference.
* If you have more options, please snarrowdown the selection of parts as meet to the conditions of pirce and/ or size of components.

► Introduction of production examples

Example 1

Molded product cap

Main components	Outside cup with Bellows	VAPH-20C-3
	Stop-gap cup	TPJG-8-S
	Suction stem	VFIL-S-5A
	Inner stem	VFILK-PS-M5

Example 2

Outside cup with bellows

Main components	Outside cup with Bellows	VAPH-20C-3
	Stop-gap cup	TPJG-8-S
	Suction stem	VFIL-S-5A
	Inner stem	VFILK-PS-M5

Example 3

Molded product caster

Main components	Outside cup with Bellows	EPLG-30-S5
	Stop-gap cup	EPJG-10-S
	Suction stem	VFILA-PHB-1/8
	Inner stem	VFILK-PIB-M5



Vacuum Gripper

▶ A small vacuum gripper. Suitable for suction and transport of small workpieces.

Vacuum Gripper		
Drawing	<p>* Connect plastic ejector SSBP series (3-49) to $\phi 8$ (ejector not attached).</p>	
Product name	Vacuum gripper 76×22·10mm	Sponge seal 76×22 w/o valve (for exchange)
Order code No.	183977	183978
TYPE	SFM-76/22-SW-10-B	SFMSEAL76/22SW10BW/OV
Weight	50.0g	1.5g

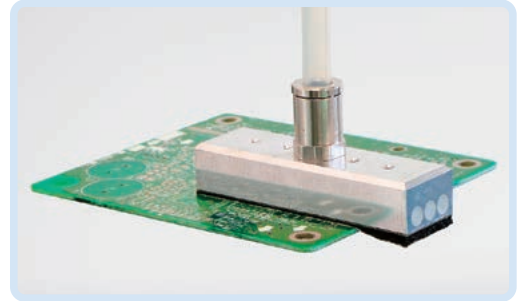

About suction surface

It's coated with sponge seal, which could reduce the abrasion and suction traces.
* Sponge seal is replaceable.

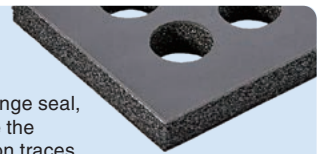

Specification

TYPE	Vacuum Gripper	Valve	Holding power* ¹ (N)	Required suction quantity* ² (L/min)	Number of cells	Weight (g)
SFM-76/22-SW-10-B	External type	Throttle valve	40	40	26	60

* 1 -60 kPa. If the entire gripper is covered by hard work piece.
* 2 The amount of suction when the vacuum gripper is connected to -60 kPa.

▶ It can transfer the work piece of different shapes with one gripper (wood, resin, cardboard, etc.).

Vacuum Gripper		
Drawing		
Product name	Vacuum gripper 120×60·10mm	Sponge seal 120×60 w/o valve (for exchange)
Order code No.	183979	183980
TYPE	SFX-120/60-SW-1.5-10-B	SFXFMSEAL120/60SW10BW/OV
Weight	500.0g	6.5g

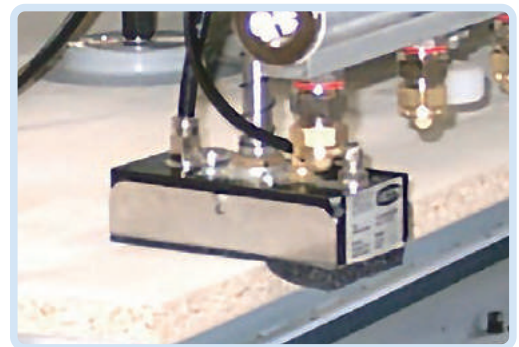

About suction surface

It's coated with sponge seal, which could reduce the abrasion and suction traces.
* Sponge seal is replaceable.

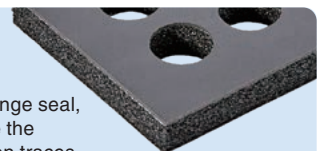

Specification

TYPE	Load tolerance* ³ (N)	Holding power* ⁴ (N)	Max suction discharge* ⁵ (L/min)	Max vacuum (%)	Air consumption (L/min)	Number of cells	Noise level (dB (A))	Supply pressure (MPa)	Allowable temperature (°C)	Weight (g)
SFX-120/60-SW-1.5-10-B	92	98	69	80	117	10	65	0.3 ~ 0.5	+5 ~ +50	500

* 3 When transporting horizontally.
* 4 The max holding power happen while the system air pressure is - 30 kPa When sucking on workpieces without ventilation. The safety rate is not included.
* 5 Supply air pressure 0.5 MPa.
* The max vacuum level, air consumption and noise level vary according to the external vacuum gripper.

MEMO

A series of horizontal dashed lines for writing.



Air Ejectors



- Perfect for transportation of heavy weight and cardboard.
- Small, lightweight, and long life.

3-47

Plastic Ejector



Lightweight and high-performance low-price ejector.

3-49

Small Air Filters



The product prevents water, oil, steel powder, and so on sucked from the vacuum side from entering the ejector.

3-48

Small Check Valve for Suction Cup



Small check valves. Please attach the pad before use.

3-50

Specification

Product name	Order code No.	TYPE	Weight (g)	Page of details	
Air ejectors	 	042116	ESVP10-A	146	3-47
	 	042129	ESVP10-A-20	169	
Air ejector w/ switch		042034	ECV-10HS	80	3-48
		042035	ECV-10HSCK	120	
Small air filters		042036	EVFL-44	20	
		042037	EVFL-66		
Plastic ejector	Plastic ejector nozzle 1.0mm 	183988	SSBP-10-S2-SDA	22	3-49
	Plastic ejector nozzle 1.5mm 	183989	SSBP-15-S2-SDA		
	Plastic ejector nozzle 2.0mm 	183991	SSBP-20-S3-SDA	50	
Plastic ejector clip mount base		183990	SBEF-PL-110 * 45	—	
Small check valve for Suction Cup		184150	SSVK-M5	3	3-50
		184151	SSVK-G1/8	11	



Air Ejectors

Perfect for transportation of heavy weight and cardboard.

NEW ▶ Air Ejectors



Air Ejectors (shaft ϕ 12)

Order code No.	042116
TYPE	ESVP10-A

● Weight : 146g

Air Ejectors (shaft ϕ 20)

Order code No.	042129
TYPE	ESVP10-A-20



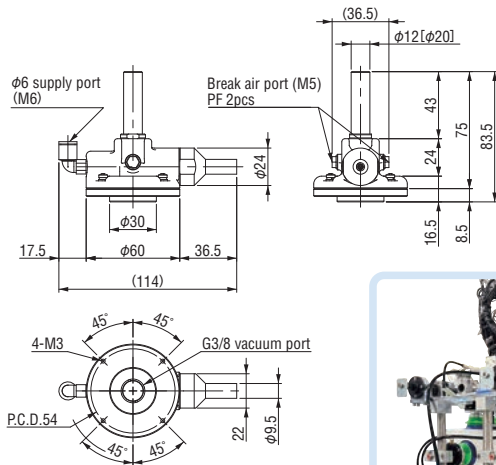

● Weight : 169g



■ Specification

TYPE	Max vacuum (-kPa)	Max suction discharge (NL/min)	Air supply pressure (MPa)	Air consumption (L/min)	Noise level (dBA)
ESVP10-A	-79.5	85	0.5	57	65 ~ 70

NEW ▶ Carrier Cup (for Ejector only)

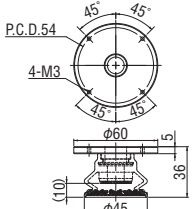
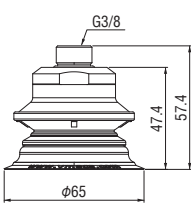
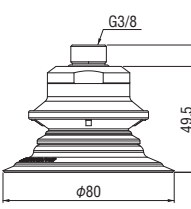
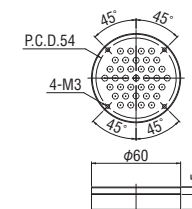
Applicable cup size	ϕ 45mm	ϕ 65mm	ϕ 80mm	ϕ 60mm
Carrier cup	 for Holder plate			 for Holder plate
Drawing				
Order code No.	042117	010749	010750	042118
TYPE	ESVP-A-PA	B1.5/60-MU65-N6-G-F2-38M	B1.5/60-MU80-N6-G-F2-38M	ESVP-A-SA
Weight	56.4g	82g	88g	40.6g

NEW ▶ Maintenance Parts

Filter

Order code No.	042119
TYPE	ESVP-FILT

● Weight : 1.5g

Seal ring

Order code No.	042132
TYPE	ESVP10-SEAL

● Weight : 0.1g

Bracket joint ϕ 12

Order code No.	042130
TYPE	ESVP10-BKTJT12

● Weight : 16g

Nozzle unit

Order code No.	042133
TYPE	ESVP10-NOZL-UT

● Weight : 20g

Joint (Elbow)

Order code No.	102051
TYPE	K02L06-M6A

● Weight : 4.3g

Bracket joint ϕ 20

Order code No.	042131
TYPE	ESVP10-BKTJT20

● Weight : 38g

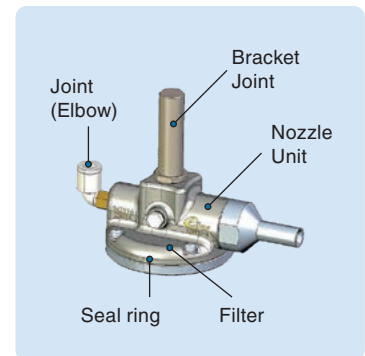

Quick Chuck Change

- Quick Chuck Change Manual
- Quick Chuck Change Manual (OM Type)
- Tool Changer
- Automated Hand Exchange System

Grip

- Mini Cylinder
- Accessories for Mini Cylinder
- Container Cylinders
- Accessories for Container Cylinder
- Grippers
- Rubber Material / Grip Pad

Suction

- Suction Cups
- Suction Stems
- Pad in Pad
- Vacuum Gripper

Air Ejector / Filter / Check Valve

- Ultra Small Part Take Out
- Vacuum Generator Unit

Cut

- Air Nipper (Small-Medium)
- Air Nipper (Large)

Frame / Module

- Jungle Gym
- Let's Joint

Rectangular Tube

- Base Aluminum Material
- Sliding Chuck

Pneumatic Components / Sensors

- Pneumatic Components
- Sensors / Multi AND Board
- PCIO Communication Unit

Lightweight Parts Series

- Frame / Suction / Resin Cylinders / Pads / Resin Manifolds

By Industry

- Logistics - Palletizing / Sheet Metal - Stamping - Metal Fabrication

Assembling Tools

- Tool / Jig

Information

- Various Products Information



Air Ejectors / Small Air Filters

▶ With vacuum switch



Order code No.	042034
TYPE	ECV-10HS
● Weight : 78g	



Order code No.	042035
TYPE	ECV-10HSCK
● Weight : 120g	

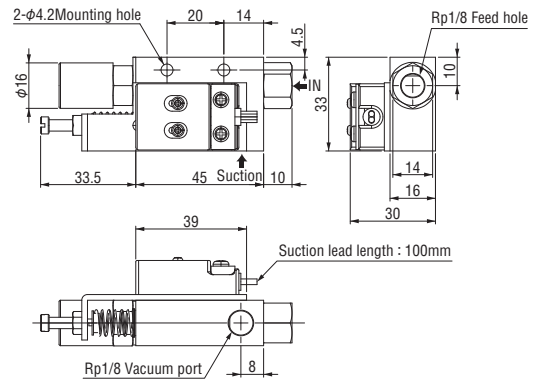
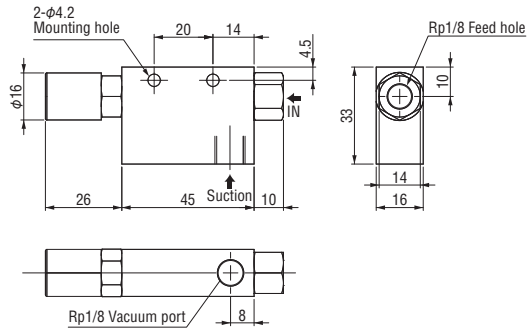

■ Specification

Product name	TYPE	Nozzle diameter (mm)	Quantity of suction (L/min)	Vacuum pressure (kPa)	Air consumption (L/min)	Supply air (MPa)
Air Ejectors	ECV-10HS	φ 1.0	27 (ANR)	- 92	44 (ANR)	0.5
	ECV-10HSCK					

▶ Small Air Filters



Order code No.	042036
TYPE	EVFL-44
● Weight : 20g ● Directional	



Order code No.	042037
TYPE	EVFL-66
● Weight : 20g ● Directional	

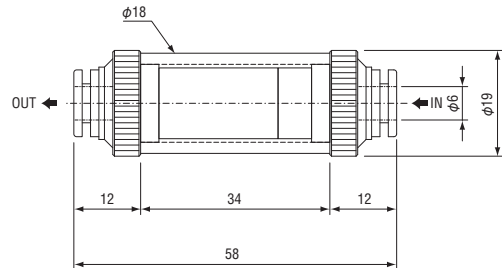
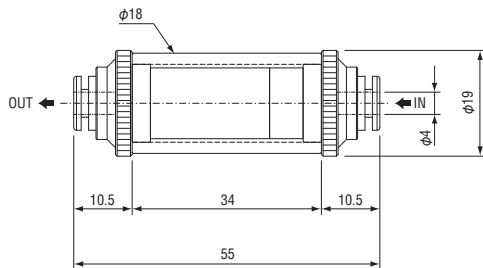

■ Specification

Product name	TYPE	Tube size (mm)	Pressure resistance (MPa)	Pressure (kPa)	Nominal filtration rating (μm)
Small Air Filters	EVFL-44	φ 4	0.5	- 95.9~0	15
	EVFL-66	φ 6			

* Vacuum filter



Plastic Ejector Nozzles

Lightweight and high-performance low-price ejector.



Plastic Ejector Nozzle 1.0mm

Order code No.	183988
TYPE	SSBP-10-S2-SDA

- Weight : 22g
- Recommended inner diameter of compressed air supply hose: 4mm (2m length)
- Recommended inner diameter of vacuum hose: 6mm (2m length)

Plastic Ejector Nozzle 1.5mm

Order code No.	183989
TYPE	SSBP-15-S2-SDA

- Weight : 22g
- Recommended inner diameter of compressed air supply hose: 4mm (2m length)
- Recommended inner diameter of vacuum hose: 6mm (2m length)

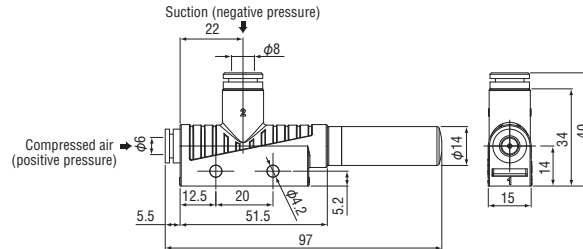

Plastic Ejector Nozzle 2.0mm

Order code No.	183991
TYPE	SSBP-20-S3-SDA

- Weight : 50g
- Recommended inner diameter of compressed air supply hose: 6mm (2m length)
- Recommended inner diameter of vacuum hose: 7mm (2m length)

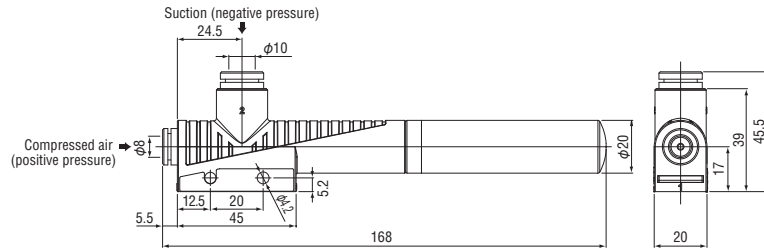

Plastic Ejector Clip Mount Base

Order code No.	183990
TYPE	SBEF-PL-110 * 45

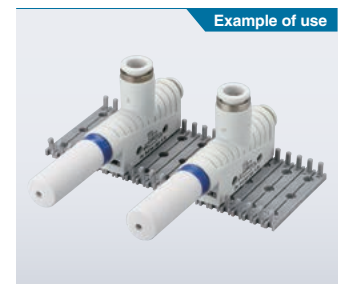
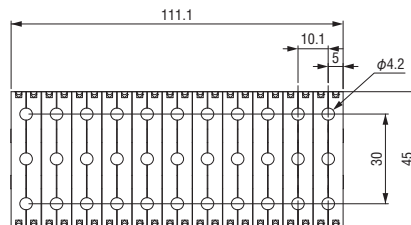

Specification

Product name	TYPE	Nozzle diameter (mm)	Max. vacuum pressure (kPa)	Quantity of suction (L/min)	Working pressure (MPa)	Air consumption (L/min) *	Noise level (db (A))	
							W/o suction	W/ suction
Plastic Ejector	SSBP-10-S2-SDA	φ 1.0	-85	37.7	0.45	48	65	59
	SSBP-15-S2-SDA	φ 1.5	-85	71.0	0.45	105	72	65
	SSBP-20-S3-SDA	φ 2.0	-85	127.0	0.45	197	77	68

* When working pressure is 0.45 MPa.

Quick Chuck Change

Quick Chuck Change Manual

Quick Chuck Change Manual (OM Type)

Tool Changer

Automated Hand Exchange System

Grip

Mini Cylinder

Accessories for Mini Cylinder

Container Cylinders

Accessories for Container Cylinder

Grippers

Rubber Material / Grip Pad

Suction

Suction Cups

Suction Stems

Pad in Pad

Vacuum Gripper

Air Ejector / Filter / Check Valve

Ultra Small Part Take Out

Vacuum Generator Unit

Cut

Air Nipper (Small-Medium)

Air Nipper (Large)

Frame / Module

Jungle Gym

Let's Joint

Rectangular Tube

Base Aluminum Material

Sliding Chuck

Pneumatic Components / Sensors

Pneumatic Components

Sensors / Multi AND Board

PCIO Communication Unit

Lightweight Parts Series

Frame / Section / Resin Cylinders / Pads / Resin Manifolds

By Industry

Logistics-Palletizing/Sheet Metal-Stamping-Metal Fabrication

Assembling Tools

Tool / Jig

Information
Various Products Information



Small Check Valve for Suction Cup



Small check valves. Please attach the pad before use.

- Remove the head of suction stem before installation.
- Used to attach to the position between suction stem head and main body to use the bracket for VFILB.

Use of check valves eliminates the need for repositioning vacuum cups when lifting workpieces of different sizes simultaneously.

The check valve cuts off the airflow to the vacuum cup when there is no contact between the cup and the workpiece.



Order code No.	184150
TYPE	SSVK-M5

● Weight : 3g



Order code No.	184151
TYPE	SSVK-G1/8

● Weight : 11g

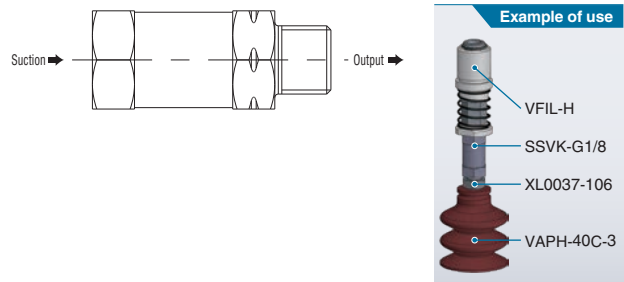
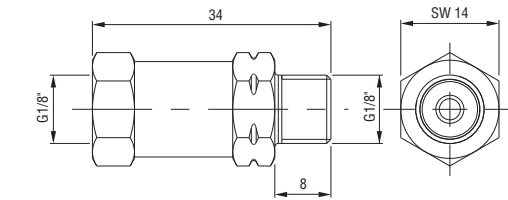
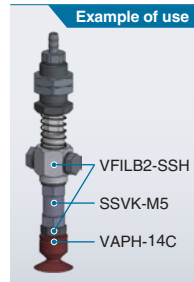
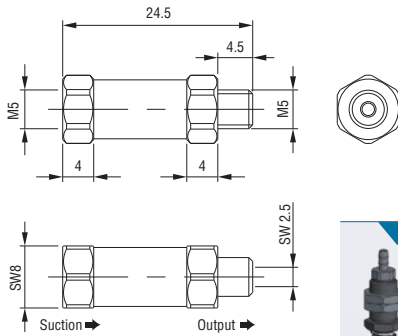

Operation of check valve



The condition in which a vacuum cup is pressed against the work surface without permeability. The ball in the valve is in the open position under vacuum.



When the work does not cover a vacuum pad completely or a pad is separated during handling. A ball is pushed up in the direction of the sheet with airflow. And vacuum pressure in the system is maintained.



The condition in which the workpiece is released. The cross-sectional area of the valve is widened when the ball is pushed back. Much air is discharged. And the workpiece is released reliably and quickly.

<Reference value>

- Suction cup** VAPH-15C
- Check Valve** SSVK-M5
- supply pressure** 0.5MPa

Quantity of suction No. of uses	(Unit : kPa)				
	0 position	1 position	2 position	3 position	4 position
Check valve: 0	-20.5	-20.5	-20.5	-20.5	-66.5
Check valve: 1	-21.0	-21.0	-21.0	-61.0	-65.4
Check valve: 2	-22.0	-22.0	-55.2	-61.9	-65.3
Check valve: 3	-25.0	-47.6	-54.1	-59.2	-64.4

*Above list: with maximum degree of vacuum of -66.5 kPa.

MEMO

A series of horizontal dashed lines for writing.



Ultra Small Part Take Out

Please submit technical information beforehand for our effective design/manufacturing.

- ▶ Small molding machine It is effective for taking out ultra-small molded products of 20 tons or less.
- ▶ Compact and high-function multi ejector is used.
- ▶ Cylindrical multi ejector can be attached to jungle gym SUS pipe.
- ▶ Fine sensor unit best suited to check the micro workpieces.

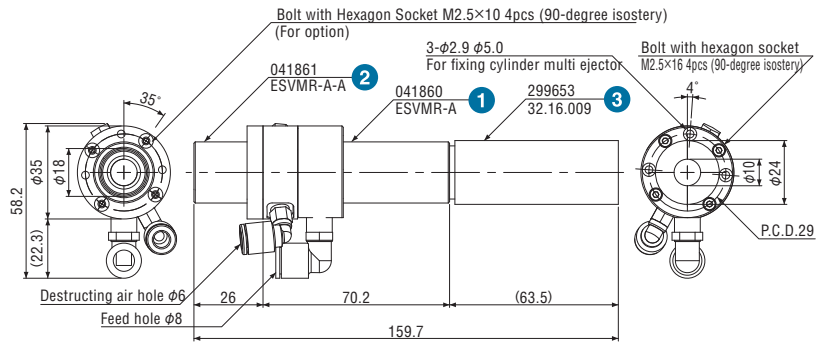
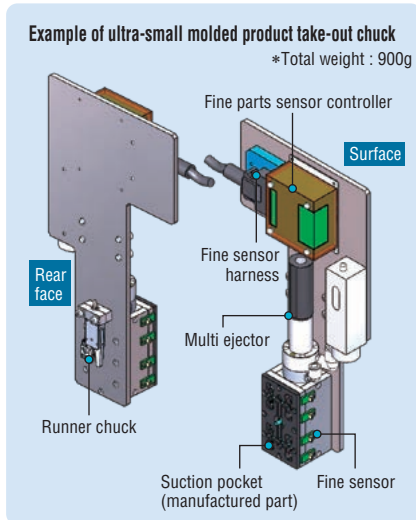

Suction • Ultra Small Part Take Out

1



Multi Ejector

Order code No.	041860
TYPE	ESVMR-A

- Weight : 104g
- Air consumption : 280 [L/min]
- Suction flow rate : 700 [L/min]
- Noise : 91.2 [dB]
- Attachments: sealing ring packing

2



Option parts A

Order code No.	041861
TYPE	ESVMR-A-A

- Weight : 19g
- Attachments: mounting bolt (M2.5 x 10) x 4
- Joint for hose connection

3



Silencer

Order code No.	299653
TYPE	32.16.009

- Weight : 13g
- Silence, Amount of suction fluid flow: 400 [L/min]



In-line Cylinder Multi Ejector

Order code No.	041836
TYPE	ESVMR1-10-3

- Weight : 64g
- Air consumption : 210 [L/min]
- Suction flow rate : 260 [L/min]
- Noise : 85 [dB]

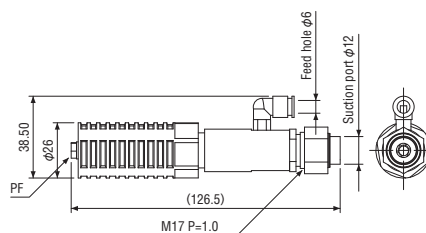

Silencer

Order code No.	110663
TYPE	L18382-106

- Weight : 22g



You can see moving images of products by using QR code reader of your smartphone.

Micro Parts Sensor Controller



Order code No.	010521
TYPE	B-CONT-UNIT

● Weight : 145g

- ▶ Product detection level mode: automatic or manual
- ▶ Switching between AND output and OR (/OR) output is possible.
- ▶ Input and output for NPN / PNP.
- ▶ Up to 32 points can be detected (extension unit is used).
- ▶ The input condition of the sensor can be confirmed with the monitor LED.
- ▶ Method of product detection can be selected from level (product condition) and latch (product pass hold).
- ▶ Light ON / Dark ON can be selected.

* The parts are subject to changes without notice.

About "AND", "/OR", and "OR"

Input side

① ② ③

AND, /OR, OR

Output S

AND	/OR	OR
Output S is turned on when all the inputs (①②③) are ON.	Output S is turned on when all the inputs (①②③) are OFF.	Output S is turned on when either of input (①②③) is ON.

Sensing input, OR switching input circuit configuration

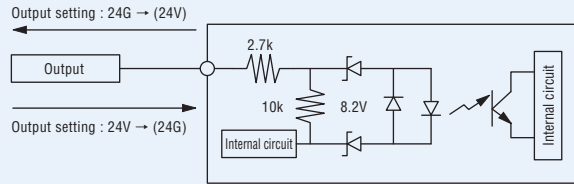

* Sensing input switching: change the input setting with the switch according to the output circuit specification of the customer (as shown in the drawing).

Configuration of output circuit

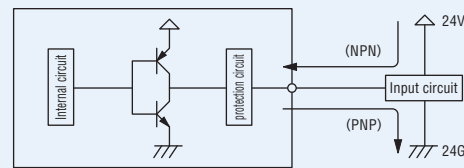

* Select NPN/PNP as illustrated above according to the input circuit specification of the customer.

Outside Dimension / Mounting Dimension

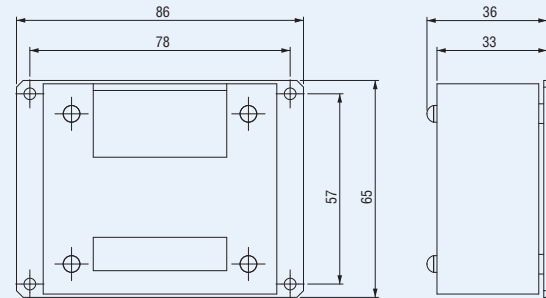

* Mounting hole : 4-φ3.5

Specification

Power supply voltage (V)	Internal consumption current (mA)	Input current (mA)	Output current (mA)	Operating ambient humidity (%)	Ambient temperature (°C)	Operation condition
DC24 (±10%)	120 max. (DC24V)	10 or less / one point	100 (MAX)	35 ~ 80 (non-condensing)	0 ~ 40	There is no particulate and corrosive gas.

Fine sensor unit

Order code No.	010519
TYPE	B-SENS-UNIT

● Weight : 1g

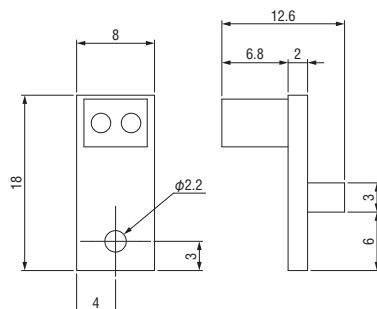

Fine sensor harness

Order code No.	010522
TYPE	B-SENS-H

- Weight : 150g
- Length : 1m
- Harness connect the fine sensor unit and fine controller unit.



Quick Chuck Change

Quick Chuck Change Manual

Quick Chuck Change Manual (OM Type)

Tool Changer

Automated Hand Exchange System

Grip

Mini Cylinder

Accessories for Mini Cylinder

Container Cylinders

Accessories for Container Cylinder

Grippers

Rubber Material / Grip Pad

Suction

Suction Cups

Suction Stems

Pad in Pad

Vacuum Gripper

Air Ejector / Filter / Check Valve

Ultra Small Part Take Out

Vacuum Generator Unit

Cut

Air Nipper (Small-Medium)

Air Nipper (Large)

Frame / Module

Jungle Gym

Let's Joint

Rectangular Tube

Base Aluminum Material

Sliding Chuck

Pneumatic Components / Sensors

Pneumatic Components

Sensors / Multi AND Board

PCIO Communication Unit

Lightweight Parts Series

Frame / Section / Resin Cylinders / Pads / Resin Manifolds

By Industry

Logistics-Palletizing/Sheet Metal-Stamping-Metal Fabrication

Assembling Tools

Tool / Jig

Information

Various Products Information



Supplying dry air allows easy generation of vacuum pressure.

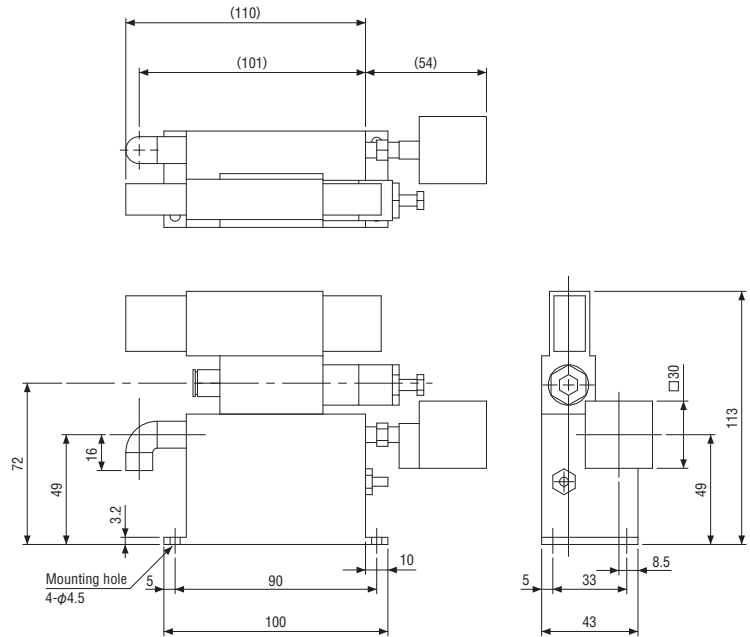

Order code No.	210804
TYPE	V51-100-8283

- Weight : 800g
- The pressure sensor facilitates the verification of the achieved vacuum pressure.
- Vacuum pressure is adjustable.

■ Specification

Fluid to be used	Pressure air regulated by air regulator with 74 μ or less of filter.
Pressure	0.35 ~ 0.5MPa
Reaching vacuum pressure	-0.079MPa or more (supply pressure 0.5MPa)
Quantity of suction	18 ± 1.5dm ³ /min ANR (Supply pressure 0.4MPa)
Air consumption (L/min)	30 ~ 40dm ³ /min ANR (Supply pressure 0.4MPa)
Weight	Approx. 10kg
2-port magnet valve	2-port magnet valve
solenoid	double solenoid
Response time	0.05sec Max
Standard voltage	DC24V
Power consumption	1.8W
Allowable voltage volatility	± 10%
Type of insulation	B type

■ Vacuum pressure sensor with display

TYPE	PG-30-102R-N (Copal Electronics)
Power supply voltage	DC10.8~30V Ripple included
Protection grade	IP65 (connector not included)
Output	NPN open collector, 30 VDC max. (100 mA max.)
Residual voltage	1.2 VDC max. (load voltage 100 mA)
Output setting pressure	-53.3 ± 5kPa (power supply voltage DC24V, ambient temperature 25 ± 5°C)
Output hysteresis setting	13.3kPa
Operation Mode	Output transistor ON, red LED lighted when negative pressure exceeds the preset pressure. (Display screen is lighted with negative pressure).
Output	Linear output (1-5VDC)